



ARTEL VIDEO SYSTEMS _____

DigiLink 1200/1220

**Single-channel Fiber Optic
Video Transmission System
Installation and Operation Guide**

Document Number: 200-000670-D02

Version: 2

Released: February 8, 2001

COPYRIGHT

This manual is produced and copyrighted by Artel Video Systems, Inc. Any use or reproduction of the contents of this manual without the prior written consent of Artel Video Systems, Inc. is strictly prohibited.

NOTICE

All title and copyrights to this document are owned by Artel Video Systems, Inc. No part of the contents of this document may be reproduced or transmitted in any form or by any means without the written permission of Artel Video Systems, Inc.

Artel Video Systems shall not be liable for errors contained herein. Artel Video Systems shall not be liable for any damages whatsoever, including, without limitation, damages for loss of business profits, business interruption, loss of business information, or other pecuniary loss arising out of the use of this documentation even if Artel Video Systems, Inc. has been made aware of the possibility of such damages.

Information contained in this document is subject to change without notice. While every effort is made to ensure that the information is accurate as of the publication date, users are reminded to update their use of this document with documents published by Artel Video Systems, Inc. subsequent to this date.

Third-party product information is for informational purposes only, and constitutes neither an endorsement nor a recommendation. Artel Video Systems, Inc. assumes no responsibility with regard to the performance of the third-party products.

Copyright © 2001 by Artel Video Systems, Inc.
ALL RIGHTS RESERVED
Printed in U.S.A.

Artel Video Systems, Inc.
237 Cedar Hill Street
Marlborough, MA 01752
(508) 303-8200

WARNINGS

The optical transmission system on some optical transmitter models is a Class I laser product only when installed in accordance with the procedures of this manual. Laser radiation is restricted to the optical cable, thus preventing human access. User modification to the system may alter the product classification and create a radiation hazard.

DO NOT, UNDER ANY CIRCUMSTANCES, stare directly into a fiber optic connector. Although the light used in most fiber optic transmissions is not visible to the naked eye, potentially harmful levels of optical laser radiation may be present at the optical output ports and unconnected receive fiber ends. Prior to applying system power, connect fiber cables to either another DigiLink unit or to an optical power meter.

The DigiLink Single Channel Fiber Optic Video Transmission System contains components that can be damaged by electrical static discharge if covers are removed. Ensure that you connect an approved anti-static wrist strap to your wrist and then connect it to an electrical ground before installing or removing covers from the unit.

CAUTION

This manual is intended for use by trained service personnel. The use of controls, adjustments, or performance of procedures other than those specified herein may result in hazardous exposure to optical radiation.

SAFETY LISTING

UL listed, file # E171306

cUL approved, file #E171306

EN 60 950: International Safety Standards

NETWORK EQUIPMENT-BUILDING SYSTEMS (NEBS)

This product is NEBS-compliant. Contact factory for details.

FEDERAL COMMUNICATIONS COMMISSIONS NOTICE

This equipment has been tested and found to comply with the limits for a Class A digital device, pursuant to Part 15 of the FCC Rules. These limits are designed to provide reasonable protection against harmful interference when the equipment is operated in a commercial environment. This equipment generates, uses, and can radiate radio frequency energy and, if not installed and used in accordance with the instructions in this manual, may cause harmful interference to radio communications. Operation of this equipment in a residential area is likely to cause harmful interference, in which case the user must correct the interference at the user's own expense.

Compliance with applicable regulations depends on the use of shielded I/O cables. The user is responsible for procuring the appropriate cables.

CANADIAN EMISSIONS REQUIREMENTS

Cet appareil numérique respecte les limites de bruits radioélectriques applicables aux appareils numériques de Classe A prescrites dans la norme sur la matériel brouilleur: "Appareils Numériques", NMB-003 édictée par le Ministère des Communications.

This digital apparatus does not exceed the Class A limits for radio noise emissions from digital apparatus as set out in the interference-causing equipment standard entitled "Digital Apparatus", ICES-003 of the Department of Communications.

INTERNATIONAL EMC REQUIREMENTS

This equipment has been tested and found to comply with the limits of the following international standards.

EN55 022 Radiated & Conducted Emissions

CISPR 22 Class A

EN50 082-1	Immunity
IEC 801-2	ESD
IEC 801-3	Immunity
IEC 801-4	EFT

Declaration of Conformity

We,

Artel Video Systems, Inc.

Located at
237 Cedar Hill Street
Marlborough, MA 01752

declare under our sole responsibility that the following DigiLink Single Channel Fiber Optic Video Transmission System products:

DL1200E, DL1200E-48
DL1200D, DL1200D-48
DL1220E, DL1220E-48
DL1220D, DL1220D-48
DL1200EN, DL1200EN-48
DL1220EN, DL1220EN-48
DL1200DN, DL1200DN-48
DL1200EL, DL1200EL-48
DL1220EL, DL1220EL-48
DL1220EP, DL1220DP
DL1220EP-48, DL1220DP-48

to which this declaration relates, is in conformity with the following standards and other normative documents:

Product Safety: EN 60 950
EMC: EN55 022, EN 50 082-1
NEBS: GR-63, GR-1089

The aforementioned products follow the provisions of the Low Voltage Directive 73/23/EEC and the EMC Directive 89/336/EEC.

Name: Chester J. Gapinski
Title: Vice President of Engineering
Date: January, 2001



Contents

About This Guide

Audience	xx
How to Use This Manual	xxi
Symbols and Conventions	xxii
Contacting Customer Service	xxiii

1 Introduction

Product Overview	1-2
DigiLink Models	1-9
Encoder Functional Description	1-13
Decoder Functional Description	1-17

2 Unpacking and Installing

Site Requirements	2-2
Required Tools and Equipment	2-3
Unpacking the Unit	2-3
Installing the Unit	2-4
Quick Start Configurations	2-7

3 Configuring and Cabling an Encoder

Encoder Front and Rear Panel Views	3-2
Identifying the Unit	3-4
Applying Power	3-5
Powering up the Encoder	3-7
Selecting the Encoder's Operating Mode	3-9
Establishing Encoder Inputs	3-15
Analog Video Input	3-16
AUDIO INPUTS	3-23
Data Inputs	3-26
Digital Video Input	3-29
Establishing Encoder Outputs	3-31
Selecting a Video Output Signal	3-32

Cabling the OPTICAL OUTPUT Port	3-36
Cabling the SDI OUTPUT Port.....	3-38
Monitoring Video and Audio Signals	3-40
Using Internal and External Display Capabilities	3-43
Using the Test Screen Editor	3-54

4 Configuring and Cabling the Decoder

Decoder Front and Rear Panel Views	4-2
Identifying the Unit	4-4
Applying Power.....	4-5
Powering up the Decoder	4-7
Establishing Decoder Inputs.....	4-9
Decoder Input Ports	4-14
Establishing Decoder Outputs.....	4-16
Analog Video Output.....	4-17
Audio Outputs	4-26
Data Outputs	4-29
Digital Audio Output.....	4-33
Using Internal and External Display Capabilities	4-35
Monitoring Video and Audio Signals	4-44
Using the Test Screen Editor.....	4-47

5 Configuration Applications

A Point-to-point Configuration.....	5-2
Using a Routing Switcher on the Electrical Link.....	5-3
Analog and Digital Switch Bridging	5-4
Dual Services Switched Network.....	5-5
Using the Encoders and Decoders for Critical Applications.....	5-6
Implementing Protection Switch Configurations	5-7
Configuration Procedures	5-8

A Fiber Optic Cables

Fiber Optic Cable Properties	A-2
Fiber Optic Cables	A-6
Selecting Fiber Optic Cable.....	A-9
Using Fiber Optic Cable.....	A-9



B Installing a Laser Cartridge

Laser Cartridge Overview	B-2
Installing a Laser Cartridge	B-4
Removing a Laser Cartridge	B-7





List of Figures

Figure 1-1.	DigiLink DL1200 Encoder Block Diagram.....	13
Figure 1-2.	DL1220 Encoder Block Diagram.....	14
Figure 1-3.	Encoder Bandwidth	16
Figure 1-4.	Decoder Block Diagram	17
Figure 1-5.	Decoder Bandwidth	18
Figure 3-1.	DigiLink Encoder Front Panel	2
Figure 3-2.	DigiLink Encoder Rear Panel.....	3
Figure 3-3.	An Encoder Label.....	4
Figure 3-4.	DC Power Supply Terminal Block	6
Figure 3-5.	Encoder POWER Switch	7
Figure 3-6.	Locating the Fan Wire Connector.....	8
Figure 3-7.	Remote TX Select Connector	12
Figure 3-8.	Example of a Remote TX Select Connection	13
Figure 3-9.	Multi-Burst Video Test Pattern	20
Figure 3-10.	An AUDIO INPUT Connector	24
Figure 3-11.	Terminator Switch-Audio Port Relationship	25
Figure 3-12.	Pinouts for the RS-232 DATA INPUTS Port.....	27
Figure 3-13.	RELAY INPUT Connectors.....	28
Figure 3-14.	REMOTE VIDEO SELECT Connector	35
Figure 3-15.	Encoder Front Panel Audio Monitor Connector	42
Figure 3-16.	Device Status LEDs.....	44
Figure 3-17.	Source Status LEDs	47
Figure 3-18.	Relay/Data LEDs.....	48
Figure 3-19.	Output Status LEDs.....	49
Figure 3-20.	AUDIO LEVEL Display and METER SELECT Switch	50
Figure 3-21.	ALARM Relay Connectors	53
Figure 3-22.	User Interface Menu Flowchart	57
Figure 3-23.	Main Menu.....	58
Figure 3-24.	Text Entry Menu	59
Figure 3-25.	Active Text Entry Feature and Character Cursor	61
Figure 3-26.	NTSC Test Patterns Menu	63
Figure 3-27.	PAL Test Patterns Menu	64
Figure 3-28.	Editor Buttons Help Menu.....	65
Figure 3-29.	<PGRM> Help Screen	65
Figure 3-30.	<ENTER> Help Screen	66
Figure 3-31.	<UP> Help Screen.....	66

Figure 3-32.	<DOWN> Help Screen	66
Figure 4-1.	DigiLink Decoder Front Panel	2
Figure 4-2.	DigiLink Decoder Rear Panel	3
Figure 4-3.	A Decoder Label	4
Figure 4-4.	DC Power Supply Terminal Block	6
Figure 4-5.	Decoder POWER Switch.....	7
Figure 4-6.	Locating the Fan Wire Connector	8
Figure 4-7.	Main Menu Mode Indications	13
Figure 4-8.	REMOTE VIDEO SELECT Connector	18
Figure 4-9.	Multi-Burst Video Test Pattern	23
Figure 4-10.	An AUDIO OUTPUT Connector	26
Figure 4-11.	AUDIO GAIN ADJUST Potentiometers	27
Figure 4-12.	Pinouts for the RS-232 DATA OUTPUTS Connector	29
Figure 4-13.	RELAY Output Connectors.....	30
Figure 4-14.	ALARM RELAY Connectors	31
Figure 4-15.	Device Status LEDs.....	36
Figure 4-16.	RELAY/DATA CHANNELS LEDs	38
Figure 4-17.	Output Status LEDs.....	39
Figure 4-18.	Receiver Light Level LED Display and Meter Select Switch.....	41
Figure 4-19.	Decoder Front Panel Audio Monitor Connector	46
Figure 4-20.	User Interface Menu Flowchart	50
Figure 4-21.	Main Menu	51
Figure 4-22.	Main Menu Screen When EDH Mode is Selected	52
Figure 4-23.	An EDH Screen with No Errors Detected	53
Figure 4-24.	An EDH Screen with an Invalid Video Signal.....	54
Figure 4-25.	An EDH Screen with a Downstream Error Detected.....	55
Figure 4-26.	Text Entry Menu	56
Figure 4-27.	Active Text Entry Feature and Character Cursor	58
Figure 4-28.	NTSC Test Patterns Menu	60
Figure 4-29.	PAL Test Patterns Menu	60
Figure 4-30.	Editor Buttons Help Menu	61
Figure 4-31.	<PGRM> Help Screen	62
Figure 4-32.	<ENTER> Help Screen	62
Figure 4-33.	<UP> Help Screen.....	62
Figure 4-34.	<DOWN> Help Screen	63
Figure 4-35.	Editor Buttons Help Menu	63
Figure 4-36.	<PGRM> Help Screen	64
Figure 4-37.	<ENTER> Help Screen	64



Figure 4-38.	<UP> Help Screen.....	64
Figure 4-39.	<DOWN> Help Screen	65
Figure 5-1.	Encoder/decoder Point-to-point Configuration.....	2
Figure 5-2.	DigiLink DL1200EN and DL1200DN Configuration	3
Figure 5-3.	Bridging an Analog and Digital Switch	4
Figure 5-4.	DL1220E and DL1220D in Dual Service Switched Network.....	5
Figure 5-5.	RS-232 Null Modem Cable Pinout.....	7
Figure 5-6.	Baseband Video In Connection	8
Figure 5-7.	Audio In Connections	9
Figure 5-8.	An Analog Mode Protection Switching Set-up	10
Figure 5-9.	SDI In Connection.....	11
Figure 5-10.	Point-to-Point Protection Switching for SDI Signal	11
Figure 5-11.	SDI Signal Flow from Encoder A to Decoder C	12
Figure 5-12.	SDI Signal Flow from Encoder B to Decoder C through Decoder D	12
Figure 5-13.	Protecting Redundant Optical Transmissions from Encoder A	13
Figure 5-14.	Protecting Redundant Optical Transmissions from Two-way Splitter	13
Figure A-1.	Modal Dispersion in Optical Fibers	3
Figure B-1.	Laser Cartridge Slot on the Encoder Rear Panel.....	4
Figure B-2.	Installing a Laser Cartridge.....	4
Figure B-3.	Optical Ports with a Laser Cartridge Installed	5





List of Tables

Table 1-1.	Laser Cartridge Models	7
Table 1-2.	DL1200 Encoder Models	9
Table 1-3.	DL1200 Decoder Models	10
Table 1-4.	DigiLink DL1220 Encoder Models	11
Table 1-5.	DigiLink DL1220 Decoder Models	12
Table 2-1.	I/O Connections: Analog Mode/Optical Transmission	7
Table 2-2.	Switch Settings: Analog Mode/Optical Transmission	7
Table 2-3.	I/O Connections: SDI Mode/Optical Transmission	8
Table 2-4.	Switch Settings: SDI Mode/Optical Transmission	8
Table 2-5.	I/O Connections: Analog Mode/Electrical Transmission	9
Table 2-6.	Switch Settings: Analog Mode/Electrical Transmission	9
Table 2-7.	I/O Connections: Artel-270 Optical Inputs	10
Table 2-8.	Switch Settings: Artel-270 Optical Inputs	10
Table 2-9.	I/O Connections: SDI Optical Inputs	11
Table 2-10.	Switch Settings: SDI Optical Inputs	11
Table 2-11.	I/O Connections: Artel-270 Electrical Inputs	12
Table 2-12.	Switch Settings: Artel-270 Electrical Inputs	12
Table 3-1.	Encoder Front Panel Elements	2
Table 3-2.	Encoder Rear Panel Elements	3
Table 3-3.	Truth Table for the Remote TX Select Connection Above	14
Table 3-4.	Device Status LEDs	45
Table 3-5.	Source Status LEDs	47
Table 3-6.	Relay/Data LEDs	48
Table 3-7.	Output Status LEDs	49
Table 3-8.	Editor Buttons and Functions	56
Table 3-9.	Main Menu Options	58
Table 3-10.	Text Entry Menu Options	60
Table 4-1.	Decoder Front Panel Elements	2
Table 4-2.	Decoder Rear Panel Elements	3
Table 4-3.	Device Status and LEDs	37
Table 4-4.	Relay/Data LEDs	39
Table 4-5.	Output Status LEDs	40
Table 4-6.	User Interface Buttons and Functions	49
Table 4-7.	Main Menu Options	51
Table 4-8.	Text Entry Menu Options	56
Table 5-1.	RS-232 Null Modem Cable Pinouts	6

Table A-1.	Graded-Index Multimode Fiber Optic Cable Characteristics	7
Table A-2.	Step-Index Singlemode Fiber Optic Cable Characteristics.....	8
Table B-1.	Laser Cartridge Models and ITU Wavelengths	2



About This Guide

This guide provides you with instructions for installing, configuring, and operating the DigiLink single-channel fiber optic 1200 and 1220 video transmission system.

Audience

This guide is intended for the following trained and qualified service personnel who are responsible for installing and operating the DigiLink:

- System installer
- Hardware technician
- System operator



How to Use This Manual

This manual contains the following five chapters and three appendixes:

Section	Provides
Chapter 1, "Introduction"	An overview of the DigiLink 1200/1220 system, including DigiLink encoder and decoder features and capabilities
Chapter 2, "Unpacking and Installing"	<ul style="list-style-type: none">• Configuration quick start tables for the DigiLink encoders and decoders• Procedures for unpacking and installing them as standalone, rack-mount, or wall-mount units
Chapter 3, "Configuring and Cabling an Encoder"	Descriptions of the encoder front and rear panel components, and instructions for setting the switches and cabling the ports and connectors
Chapter 4, "Configuring and Cabling the Decoder"	Descriptions of the decoder front and rear panel components, and instructions for setting the switches and cabling the ports and connectors
Chapter 5, "Configuration Applications"	Examples of application configurations, including <ul style="list-style-type: none">• Point-to-point communication between a DigiLink encoder and decoder• Integrating digital switching in a DigiLink system• Setting up a protection switching configuration for high-availability systems
Appendix A, "Fiber Optic Cables"	Specifications for DigiLink 1200/1220 encoders and decoders
Appendix B, "Installing a Laser Cartridge"	Reference material for selecting fiber cables
Appendix B, "Installing a Laser Cartridge"	Instructions for installing and removing an optional laser cartridge
Index	An alphabetical listing of topics in this manual

Symbols and Conventions

This manual uses the following symbols and conventions.

Caution

A caution means that a specific action you take or fail to take could cause harm to the equipment or to the data transmission.



Warning

A warning describes an action you take or fail to take that could result in death, serious physical injury, or destruction of property.

Note: Important related information, reminders, and recommendations.

Italics—used for emphasis, for indicating the first occurrence of a new term, and for book titles

1. Numbered list—where the order of the items is important
- Bulleted list—where the items are of equal importance and their order is unimportant



Contacting Customer Service

To contact Artel Customer Service, call 1-800-225-0228.

When requesting assistance, please be ready to provide the following information:

- Your name and telephone number
- Product model and serial number
- Brief description of the problem
- List of symptoms
- Steps you have already taken to try to resolve the problem

If the product is damaged

If any portion of the unit is damaged, forward an immediate request to the delivering carrier to perform an inspection of the product and to prepare a damage report. Save the container and all packing materials until the contents are verified.

Concurrently, report the nature and extent of the damage to Artel Customer Service so that action can be initiated to either repair or replace the damaged items.

Do not return any items to Artel until you obtain instructions from Customer Service.

Report the problem or deficiency to Customer Service along with the model number and serial number. Upon receipt of this information, Artel will provide you with service instructions, or a *Return Authorization Number* and shipping information.





1

Introduction

This chapter provides an introduction to the DigiLink 1200/1220 single-channel fiber optic video transmission system (hereafter referred to as *DL1200*, *DL1220* or *DigiLink*). DigiLink products include several models of encoders and decoders.

This chapter contains the following sections:

- [Product Overview \(page 1-2\)](#)
- [DigiLink Models \(page 1-9\)](#)
- [Encoder Functional Description \(page 1-13\)](#)
- [Decoder Functional Description \(page 1-17\)](#)

Product Overview

A DigiLink 1200/1220 transmission system performs noncompressed digital encoding, reception, and decoding of broadcast-quality baseband analog video television signals. As part of the encoding process, audio, data, and system status information are multiplexed with the video in a serial digital bit stream. The signal is transmitted and received in a format called *Artel-270*.

DL1200 and DL1220 encoders can transmit either:

- Optically over a single fiber optic cable
- Electrically over a coaxial cable

The DL1220 encoders and decoders have three features that distinguish them from the DL1200 devices:

- The ability to receive and transmit standard 270 Mbit/s serial digital interface (SDI) signals instead of baseband analog video
- The ability (on the decoder end) to perform error detection handling (EDH) when an SDI signal in SMPTE 259M-C 4:2:2 format is being received

Architecture

The DigiLink architecture is based on 12-bit analog-to-digital (A/D) video sampling and 18-bit audio sampling. This architecture enables the DigiLink performance to exceed the requirements of the EIA RS250C (short-haul) standard. This state-of-the-art encoding scheme:

- Supports point-to-point and multidrop applications
- Ensures freedom from digital artifacts
- Adheres strictly to differential gain and phase error limits
- Provides ample headroom to accommodate in-band audio subcarriers and other operating conditions



Operating Modes

All DL1200 and DL1220 encoders and decoders have the ability to operate in *analog mode*—i.e., analog video, analog audio, and digital data inputs encoded in Artel-270 digital format.

The DL1220 encoders and decoders can also operate in *SDI mode*—i.e., a digital video input is received, equalized, reclocked, and transmitted in a standard SMPTE 259M-C 4:2:2 (270 Mbit/s) format; it can also support SMPTE 305M, DVB-ASI, and other related 270 Mb/s services.

The DL1220 decoders also have a third operating mode—*EDH mode*. In EDH mode, the decoder can be monitored for on-board and down-stream signal error conditions when it receives an SMPTE 259M-C 4:2:2 SDI signal.

Analog Mode

A DigiLink encoder in analog mode encodes and transmits video, audio and data in the Artel-270 signal format, enabling you to establish an analog-to-digital network. This digital encoding scheme eliminates audio and video interaction and permits long-distance transmission with minimal degradation of signal quality.

The Artel-270 signal takes as its input:

- One wideband (8.5 MHz) video signal
- Four baseband audio channels (20 kHz each)
- Eight RS-232 (simplex, DC-to-19.2 kbit/s) protocol-transparent data channels
- Four relay channels that can be used to send control information to the decoder—e.g., *contact closure in* at the encoder end creates a *contact closure out* at the decoder end)

Device status (the presence or absence of device alarm conditions) is continually monitored, and status information for virtually all functions can be obtained using the front or rear panel.

[Figure 1-1 on page 1-13](#) illustrates the way an encoder handles inputs and outputs in analog mode.

Note: Because Artel-270 is a proprietary signal, Artel equipment must be used on both ends of the system. DigiLink encoders and decoders have a selectable data rate of 269.5 or 270 Mbit/s, allowing analog mode communication from the encoder to both older and newer DigiLink decoder models (see [page 3-34](#) for more details).

SDI Mode

When a DL1220 encoder or decoder is in SDI mode, it is a data-transparent 270 Mb/s transport system. It can transmit/receive a standard 270 Mbit/s serial digital interface signal that complies with SMPTE 259M-C 4:2:2 component signal formats (such as D1 tape) and with ITU 601; it can also support SMPTE 305M, DVB-ASI, and other related 270 Mb/s services.

Note: The DL1220 encoder cannot embed analog audio or digital data into its SDI transmission. This multiplexing capability is available only in when the encoder is operating in analog mode. The block diagram in [Figure 1-2 on page 1-14](#) shows how the encoder works in SDI mode.

EDH Mode

Error Detection Handling (EDH) mode is available only in DL1220 decoders. EDH mode provides enhanced error detection monitoring capability. The received signal must be one of the following standards: SMPTE-259M-C 4:2:2, SMPTE-305M, or ITU-R BT.657 compatible format. Also, EDH requires a RP-165 compliant signal.

Caution

If an Artel-270 signal is sent to a DL1220 decoder in EDH mode, the SDI electrical output from the decoder is disabled.

If another SDI signal type (such as DVB-ASI) is sent to a DL1220 decoder in EDH mode, the encoder-decoder link will fail.



When a DL1220 decoder is in EDH mode, you can use the test monitor output on the decoder front panel (described on [page 4-47](#)) to view the status of error flags. These flags identify:

- Whether or not video is present in the signal the decoder is receiving
- Whether or not the EDH packet is present in the received signal (the EDH packet is optional in an SMPTE 259M-C signal)
- When an error is detected, whether it has occurred in the full field of the transmission or whether it is only in the active picture field of the signal (Error Detected Here (EDH) flag)
- When an error has occurred down stream in other equipment (Error Detected Already (EDA) flag)

Transport/Reception Mechanisms

The encoder can transmit its output signal (Artel-270 or SDI) via two mechanisms:

- A fiber optic link over distances up to 120 km (74.5 miles)
- An electrical (coaxial cable) link over distances up to 250 m (820 ft)

DigiLink encoders are available with a built-in 1330 nm or 1550 nm laser to support optical transmission. If your link is electrical or if you want to use an ITU-standard notched laser for a dense wavelength division multiplexing (DWDM) application, you can order a DigiLink encoder without a built-in laser. All encoders have a compartment on the rear panel in which you can install an optional laser cartridge. The available laser cartridge models and their wavelengths are listed in [Table 1-1 on page 1-7](#).

All DigiLink decoders have an electrical input port for receiving electrically transmitted digital signals. Most decoders also have a built-in optical receiver and optical input port that allow them to receive optically transmitted signals—the exceptions are the DL1200DN and DPL1200DPN decoders, which can receive only electrically transmitted signals.

Optical Transport

The optical transmitter in a DigiLink encoder converts a high-speed bit stream output to pulses of laser light and couples them into a singlemode optical fiber. The optical output is transmitted through an FC-PC female connector. All encoders with built-in lasers have an optical output connector on their rear panel; user-installable laser cartridges also provide an optical output connector.

Laser diode optical output power and bias current are monitored continuously. Alarms will be generated if the laser bias current increases beyond a preset limit (indicating that the laser diode is degrading) or if the optical output power decreases by 1.25 dB or more below its initial value.

DigiLink optical systems are intended for 9/125 μm singlemode fiber cable plants, but you can use it over short distances with multimode fiber if sufficient modal bandwidth is maintained. The output power launched into the multimode fibers is the same as the power launched into a singlemode fiber.

The maximum usable transmission distance between an encoder and decoder (assuming premium grade optical fiber) is:

- 61.5 km (38 mi) for 9 μm singlemode fiber with a 1310 nm laser
- 120 km (74.5 mi) for 9 μm singlemode fiber with a standard 1550 nm laser or a DWDM notched laser
- 136 km (85 mi)) for 9 μm singlemode fiber with a high-power 1550 nm laser
- 2.7 km (1.7 mi) for 62.5 μm graded-index multimode fiber
- 4.4 km (2.7 mi) for 50 μm graded-index multimode fiber

Electrical Transport

An encoder can transmit its output signal electrically over coaxial cable to a destination device up to 250 m (820 ft) away. Because of the relatively short transmission distance offered by the electrical link, optical links are generally used for point-to-point communications between an encoder and a decoder. The electrical link is used primarily to send the encoder's output signal to a digital switching device where it can be amplified and redistributed to one or more decoders. This application is described on [page 5-3](#).



Laser Cartridges

All DigiLink encoders have a slot on the rear panel that accepts an optional laser cartridge. By installing a laser cartridge, you can:

- Customize the encoder's wavelength
- Configure up to 16 DigiLink encoder transmissions on different notched wavelengths and optically multiplex them via the Artel MegaWav system onto a single fiber pathway—this is *dense wavelength division multiplexing* (DWDM)
- Add an optical capability to a DL1200EN or DL1220EN encoder, which do *not* have built-in lasers
- Establish redundant 1310 nm or 1550 nm optical channels in encoders that do have built-in optics

Table 1-1 lists the 19 laser cartridge types available from Artel. This group includes standard 1310 nm and 1550 nm lasers, a special high-power 1550 nm laser, and 16 ITU-standard notched wavelengths for DWDM.

Table 1-1. Laser Cartridge Models

Model Number	Wavelength (nm)	ITU Channel Number	ITU Frequency (GHz)
WL13	1310 (± 30)		
WL15	1550 (± 30)		
WL15+4	1550 @ +4dBm		
WL51	1536.61	51	195,100
WL49	1538.19	49	194,900
WL47	1539.77	47	194,700
WL45	1541.35	45	194,500
WL43	1542.94	43	194,300
WL41	1544.52	41	194,100
WL39	1546.12	39	193,900
WL37	1547.71	37	193,700
WL35	1549.31	35	193,500

Model Number	Wavelength (nm)	ITU Channel Number	ITU Frequency (GHz)
WL33	1550.92	33	193,300
WL31	1552.52	31	193,100
WL29	1554.13	29	192,900
WL27	1555.74	27	192,700
WL25	1557.36	25	192,500
WL23	1558.98	23	192,300
WL21	1560.61	21	192,100

The TX port on the WL13 is labeled 1310, the TX port on the WL15 and WL15+4 cartridges are labeled 1550, and the TX port on the DWDM lasers is labeled with the laser's ITU channel number, as listed above. For example, the port on a 1552.52 nm DWDM laser is labeled 31.

You can also determine the wavelength of an installed laser cartridge using the METER SELECT switch and AUDIO LEVEL display on the encoder's front panel (see [page 3-50](#) for details).



DigiLink Models

DigiLink encoders and decoders are available with an on-board AC or DC power supply, and with either an NTSC or PAL test signal generator.

There are two general classes of DigiLink products:

- *DL1200* models, which transmit and receive Artel-270 signals in analog mode
- *DL1220* models, which can operate in either analog or SDI mode

The DL1200 Products

Table 1-2 lists the available DL1200 encoders. These encoders transmit analog video along with baseband audio, data, and system status information as an Artel-270 digital output.

Table 1-2. DL1200 Encoder Models

Model	Power Supply	Test Signal Generator	Optics	Electrical Support
DL1200E	AC	NTSC	Built-in 1310 nm laser and insertable laser cartridge option for Artel-270 transmission	The SDI OUTPUT port supports the electrical transmission of Artel-270 over coaxial cable
DL1200E-48	DC			
DL1200EP	AC	PAL		
DL1200EP-48	DC			
DL1200EL	AC	NTSC	Built-in 1550 nm laser and insertable laser cartridge option for Artel-270 transmission	
DL1200EL-48	DC			
DL1200EPL	AC	PAL		
DL1200EPL-48	DC			
DL1200EN	AC	NTSC	Insertable laser cartridge option for Artel-270 transmission; <i>no built-in laser</i>	
DL1200EN-48	DC			
DL1200EPN	AC	PAL		
DL1200EPN-48	DC			

Table 1-3 lists the available DL1200 *decoders*, which can receive and decode Artel-270 transmissions from a DL1200 or DL1220 encoder.

Table 1-3. DL1200 Decoder Models

Model	Power Supply	Test Signal Generator	Optics	Electrical Support
DL1200D	AC	NTSC	Optical receiver for Artel-270 signal reception over an optical link	Cable equalizer for Artel-270 reception over coaxial cable
DL1200D-48	DC			
DL1200DP	AC	PAL		
DL1200DP-48	DC			
DL1200DN	AC	NTSC	Optical link is not supported	
DL1200DN-48	DC			
DL1200DPN	AC	PAL		
DL1200DPN-48	DC			



The DL1220 Products

Table 1-4 lists the available DL1220 encoders. DL1220 encoders can operate in either of two digital signal transport modes—*analog mode* (for Artel-270 digital signals) or *SDI mode* (for SMPTE 259M-C 4:2:2 component signals, SMPTE 305M, DVB-ASI, and other related 270 Mb/s services).

Table 1-4. DigiLink DL1220 Encoder Models

Model	Power Supply	Test Signal Generator	Optics	Electrical Support
DL1220E	AC	NTSC	Built-in 1310 nm laser and insertable laser cartridge option for Artel-270 or SDI transmission	The SDI OUTPUT port supports the electrical transmission of Artel-270 or SDI over coaxial cable
DL1220E-48	DC			
DL1220EP	AC	PAL		
DL1220EP-48	DC			
DL1220EL	AC	NTSC	Built-in 1550 nm laser and insertable laser cartridge option for Artel-270 or SDI transmission	
DL1220EL-48	DC			
DL1220EPL	AC	PAL		
DL1220EPL-48	DC			
DL1220EN	AC	NTSC	Insertable laser cartridge option for Artel-270 or SDI transmission; <i>no built-in laser</i>	
DL1220EN-48	DC			
DL1220EPN	AC	PAL		
DL1220EPN-48	DC			

Table 1-5 lists the DL1220 decoders, which can receive and decode Artel-270 signals from a DL1200 or DL1220 encoder, or receive SDI signals from a DL1220 encoder.

Table 1-5. DigiLink DL1220 Decoder Models

Model	Power Supply	Test Signal Generator	Optics	Electrical Support
DL1220D	AC	NTSC	Optical receiver for Artel-270 or SDI reception over an optical link	Cable equalizer for Artel-270 or SDI reception over coaxial cable
DL1220D-48	DC			
DL1220DP	AC	PAL		
DL1220DP-48	DC			

Note: DL1220 decoders also offer an EDH (error detection handling) operating mode, which should be used only when the decoder is receiving as its input an SDI signal in SMPTE 259M-C 4:2:2 format.



Encoder Functional Description

Analog mode

Figure 1-1 is a block diagram of a DL1200 encoder. It illustrates the analog mode of A/D conversion that is supported by all DigiLink encoders.

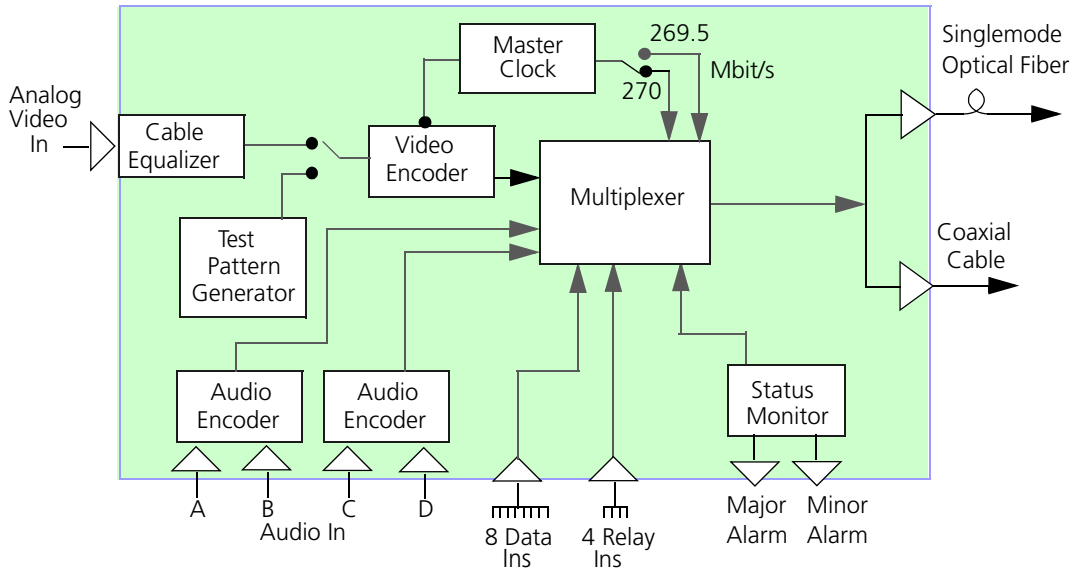

Figure 1-1. DigiLink DL1200 Encoder Block Diagram

When analog video is input to the encoder, it is encoded and multiplexed with encoded audio, data, relay control, and system status as an Artel-270 digital output signal. If analog video is not available, a test pattern generated by the encoder (with stored text that you can create) can be passed to the multiplexer in its place.

The Artel-270 output can be transmitted at either 269.5 or 270 Mbit/s over the encoder's optical and/or electrical link(s).

SDI Mode

Figure 1-2 illustrates the DL1220 encoder block diagram. It highlights (white boxes) the SDI capability inherent in the DL1220 encoders. The standard *analog* mode (Artel-270) capabilities described on page 1-3 are also supported by the DL1220 encoders— they are shaded in this block diagram.

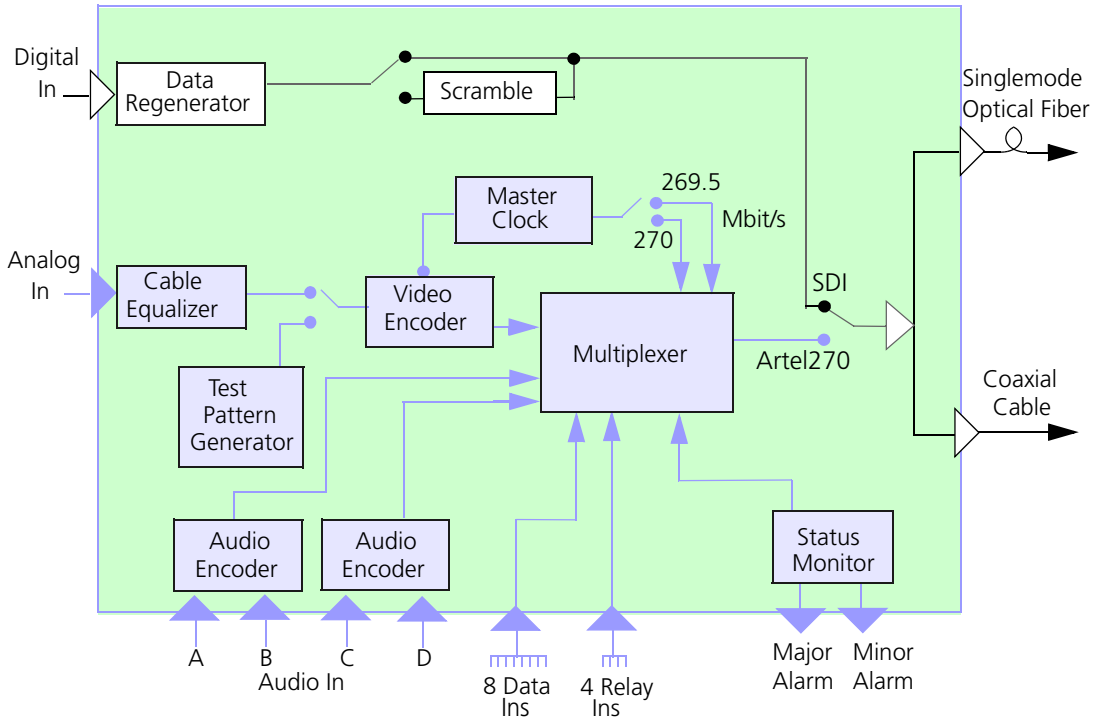

Figure 1-2. DL1220 Encoder Block Diagram

Note: The SDI input signal is equalized, relocked, and optionally scrambled by the encoder before it is passed as a digital output. The encoder cannot multiplex audio, data, or status information into the SDI output signal.



Video Input Channel Operation

The DigiLink video encoder signal path consists of:

- A high-impedance differential input stage
(This stage eliminates low-frequency common mode noise.)
- A level restorer circuit keyed to the video backporch
- A cable equalizer

Additional Notes (Video Input Channel Operation)

- The video source can be up to 300 m (328 yd) from the encoder.
- The video signal is passed through an anti-aliasing filter and encoded by a high-speed sampling 12-bit A/D converter.
- Audio data bits and ancillary data are multiplexed *with* video data into the Artel-270 13-bit format.

Information concerning encoder video bandwidth capacity is presented in [Figure 1-3](#) (see [page 1-16](#)).

Encoder video bandwidth

As shown in Figure 1-3, the 8.5 MHz video bandwidth provides ample spectrum to carry NTSC video, PAL, SECAM, B-MAC, and FM audio subcarriers.

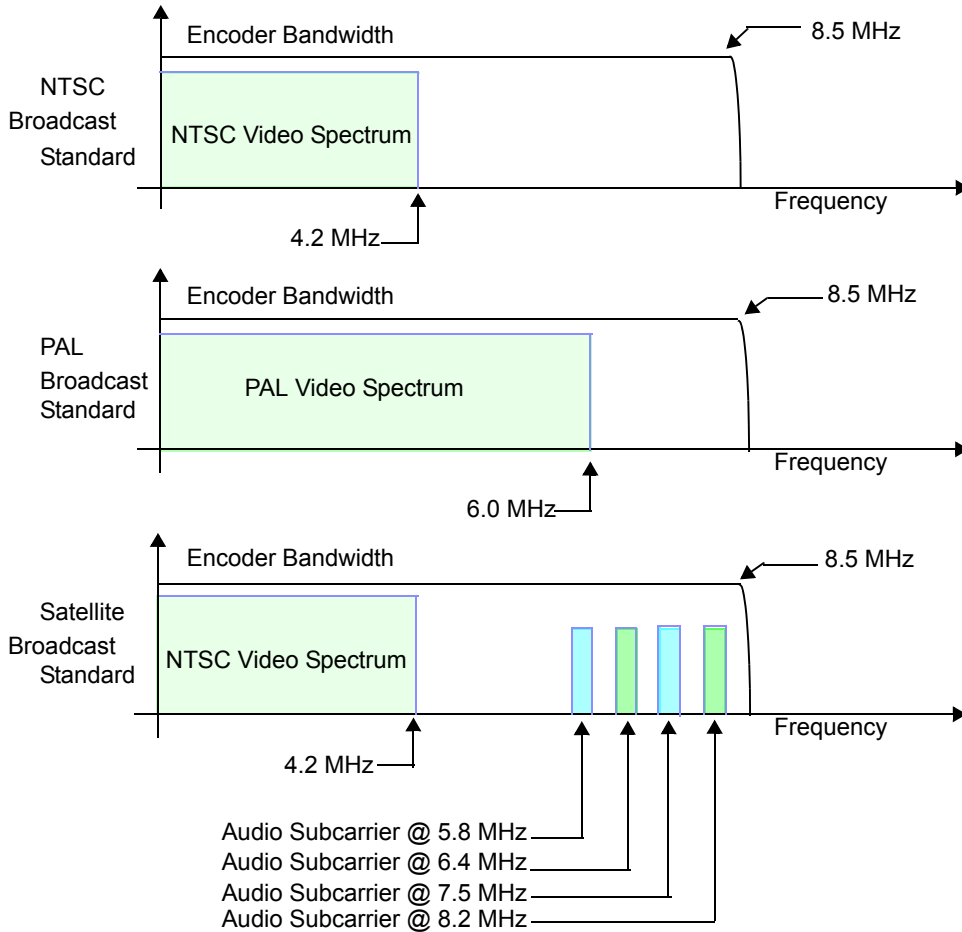

Figure 1-3. Encoder Bandwidth



Decoder Functional Description

Figure 1-4 shows the typical block diagram for a DigiLink decoder.

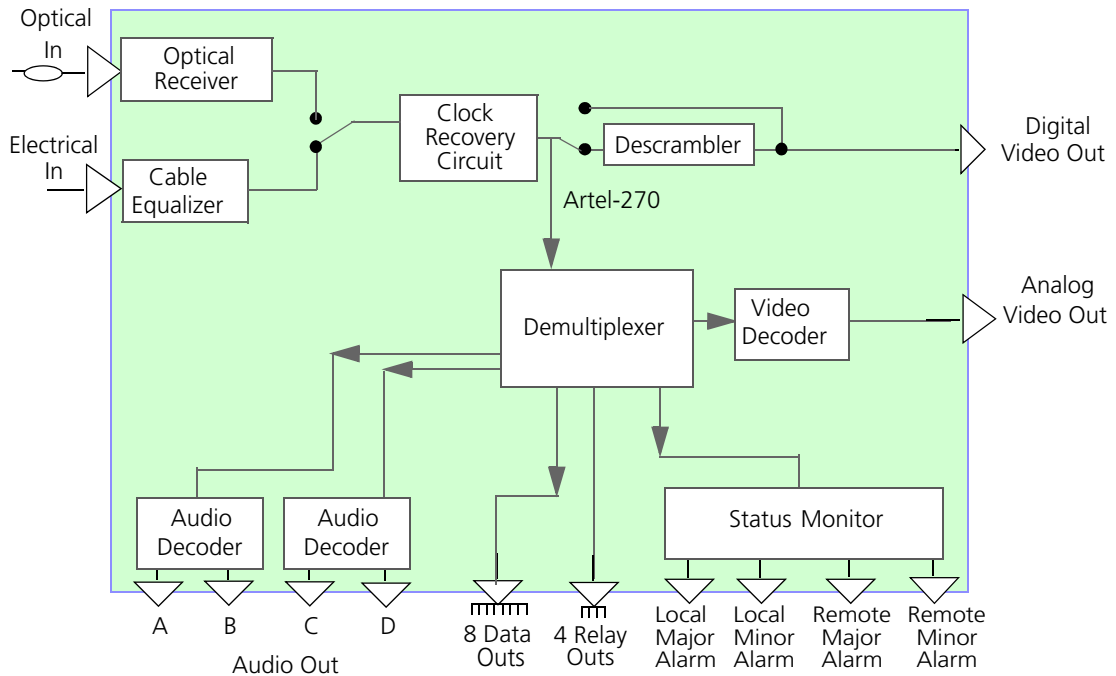

Figure 1-4. Decoder Block Diagram

The decoder handles an Artel-270 input signal by descrambling it, demultiplexing it, and transmitting the analog video, audio, and data elements as discrete outputs. With an SDI input signal, the *DL1220* decoder optionally descrambles it and then transmits it as a digital output.

Note: In the case of the *DL1200* decoders, the input signal must be an Artel-270 signal—there is *no* SDI output or descramble.

The status monitor for the decoder will check the operations of the decoder for local alarm conditions and display them on the LEDs if and when they are detected. When it receives an Artel-270 input, it will also indicate the current alarm status of the encoder, based on status information that the encoder embeds in its output signal.

Decoder video bandwidth

The DigiLink decoder video bandwidth is 8.5 MHz as shown in [Figure 1-5](#).

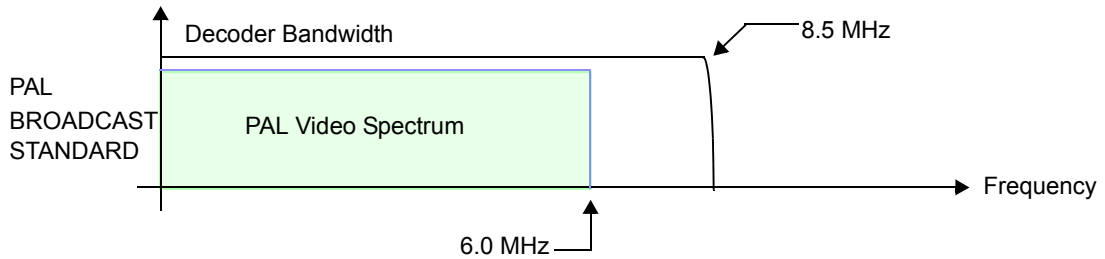

Figure 1-5. Decoder Bandwidth

Where to Go Next

[Chapter 2](#) provides configuration quick start and installation information for the DigiLink encoders and decoders.



2

Unpacking and Installing

This chapter provides encoder and decoder configuration quick start tables. It also describes how to unpack DigiLink encoders and decoders and install them as free-standing, rack-mount, or wall-mount units.

This chapter contains the following sections:

- [Site Requirements \(page 2-2\)](#)
- [Required Tools and Equipment \(page 2-3\)](#)
- [Unpacking the Unit \(page 2-3\)](#)
- [Installing the Unit \(page 2-4\)](#)
- [Quick Start Configurations \(page 2-7\)](#)

Site Requirements

Before you select an installation site for the DigiLink, read the electrical, environmental, and physical requirements specified in [Appendix A](#).



Warning

Never stare directly into a fiber optic connector.

Although the light used in most fiber optic transmissions is not visible to the naked eye, potentially harmful levels of radiation may be present at the optical output ports and unconnected transmit fiber ends.

Failure to observe this warning could result in personal injury.



Warning

Do not remove the DigiLink cover.

There are electrical shock hazards present in the unit if the cover is removed, and there are no operator-serviceable components beneath it.

Failure to observe this caution could result in injury and damage to equipment. The warranty is voided if you break the warranty seals.



Required Tools and Equipment

To install the DigiLink as a rack-mounted or wall-mount unit, you need:

- A screwdriver
- Four screws
- A $\frac{3}{8}$ inch wrench, if you are installing the optional 390-000008-00 protective cover plate (see [page 2-6](#))

Unpacking the Unit

1. Remove the unit from the shipping carton. Set aside the packing material in case you need to repackage the unit later.
2. Check the configuration of the unit against the items listed on the packing slip. If you find any discrepancies, report them in accordance with the instruction on [page xxiii](#).

Shipment Contents

The DigiLink shipment contains the following items:

- One DigiLink unit
- 13 three-pin screw wire clamp connectors
- One copy of this manual
- AC power cord (if the unit is an AC unit)

Installing the Unit

The DigiLink can be placed on a flat surface as a free-standing unit or rack-mounted in a standard 48.26 cm (19 inch) wide equipment cabinet. As you position the DigiLink for installation, keep in mind that all cables will connect to the back of the unit.

The following sections describe:

- [Installing the DigiLink as a Free-standing Unit](#)
- [Rack-mounting the Unit](#)
- [Wall-mounting the Unit](#)

Installing the DigiLink as a Free-standing Unit

To install the DigiLink as a free-standing unit, position the unit on the selected flat surface.

Note: For proper ventilation, allow at least 2 in (51 mm) of airflow space on both sides of the chassis.

Note: For proper power supply cooling, ensure that the power supply fan is not blocked. The fan is located on the right side of the rear panel of the encoder or decoder. Refer also to [Figure 3-2](#) (encoder rear panel view) and [Figure 4-2](#) (decoder rear panel view).

Refer to [Appendix A](#) for environmental specifications.

Rack-mounting the Unit

Before you rack-mount the unit, determine if you want to flush-mount or mid-mount the chassis into the cabinet. Flush-mounting sets the front edge of the unit even with the front edge of the rack. Mid-mounting causes the front edge of the unit to protrude from the front of the rack.

The DigiLink flush-mounted brackets are factory pre-installed for a flush-mount installation.

**To mid-mount the chassis:**

1. Remove the three screws securing each mounting bracket to the unit.
2. Rotate the mounting brackets 180° so the flanges are facing the rear of the unit.
3. Replace the three screws to secure each mounting bracket to the unit.

Once the mounting brackets are in position, you are ready to install the unit. When installing the unit, note the following considerations:

Note: For proper ventilation, allow at least 2 in (51 mm) of airflow space on both sides of the chassis.

Note: For proper power supply cooling, ensure that the power supply fans are not blocked.

To install the DigiLink into a rack:

1. Raise the unit to the appropriate installation height.
2. Align the screw holes on the mounting brackets with the screw holes on the equipment rack.
3. Install the screws through the mounting brackets on the unit into the mounting brackets on the rack. The unit requires two screws for each side of the chassis.

Wall-mounting the Unit

To install the DigiLink as a wall-mounted unit:

1. Remove the three screws securing the mounting brackets to the unit.
2. Rotate the mounting brackets 90° to position the flange parallel to the top of the unit.
3. Replace the three screws to secure the mounting brackets to the unit.
4. Attach the unit to the wall.

Installing the Optional Protective Cover Plate

An optional transparent protective cover plate can be ordered separately from Artel (part number 390-000008-00).

This add-on device was designed to fit on all Artel 1 RU devices.

The optional protective cover plate:

- Prevents accidental changes to switch settings on the unit's front panel
- Is transparent so you can monitor front panel LEDs
- Has two cut-out openings that enable you to access the POWER switch and the MONITOR port BNC connector

The Protective Cover Plate Kit includes the following:

- Standoffs
- Screws
- Installation instructions for open-mount and cabinet-mount installations



Quick Start Configurations

The following sections provide an overview of some input/output connections and switch settings for DigiLink encoders and decoders. These settings are meant as quick start references only. Various optional switch and connector combinations may be used for special applications—see [Chapter 3](#) and [Chapter 4](#) for more details.

Encoder Configurations

[Table 2-1](#) ... [Table 2-6](#) provide some basic parameter and connector settings for encoders under three different types of operating conditions.

Quick Start 1: An encoder in analog mode transmitting optical outputs

Table 2-1. I/O Connections: Analog Mode/Optical Transmission

INPUTS				OUTPUTS		
Video BNC Port	Audio Connectors	Data Port	Relays	Signal XMIT Port	Test and Analysis Port	Alarm Relays
VIDEO INPUT	AUDIO A	RS-232 DATA INPUTS	RELAY 1	OPTICAL OUTPUT	VIDEO MONITOR	LOCAL MAJOR
	AUDIO B		RELAY 2			
	AUDIO C		RELAY 3		AUDIO MONITOR	LOCAL MINOR
	AUDIO D		RELAY 4			

Table 2-2. Switch Settings: Analog Mode/Optical Transmission

TRANSMIT SOURCE SELECT	75 OHMS	VIDEO COUPLING	600 OHMS	VIDEO SELECT	DATA RATE MBPS	MONITOR SOURCE SELECT
ANALOG	ON	CLAMP	ON (for each AUDIO connector used)	MAIN	270	MAIN

Quick Start 2: A 1220 encoder in SDI mode transmitting optical outputs

Table 2-3. I/O Connections: SDI Mode/Optical Transmission

Input Signal Port	Output Signal Port	Alarm Output Relays	Video Monitor Port
SDI INPUT	OPTICAL OUTPUT	LOCAL MAJOR	SDI OUTPUT
		LOCAL MINOR	

Table 2-4. Switch Settings: SDI Mode/Optical Transmission

TRANSMIT SOURCE SELECT	SCRAMBLE
SDI	OFF* (Make sure the SCRAMBLE switch on the decoder is OFF also)
* If you are using both a DigiLink encoder and DigiLink decoder for SDI transmission/reception, setting the SCRAMBLE switch on both devices to ON may be desirable. Scrambling and descrambling requires that all Artel equipment be used.	



Quick Start 3: An encoder in analog mode transmitting electrical outputs through a routing switcher

Table 2-5. I/O Connections: Analog Mode/Electrical Transmission

Inputs				Outputs	
Video BNC Port	Audio Connectors	Data Port	Relays	Signal XMIT Port	Alarm Relays
VIDEO INPUT	AUDIO A	RS-232 DATA INPUTS	RELAY 1	SDI OUTPUT	LOCAL MAJOR
	AUDIO B		RELAY 2		LOCAL MINOR
	AUDIO C		RELAY 3		
	AUDIO D		RELAY 4		

Table 2-6. Switch Settings: Analog Mode/Electrical Transmission

TRANSMIT SOURCE SELECT	75 OHMS	VIDEO COUPLING	600 OHMS	VIDEO SELECT	DATA RATE MBPS
ANALOG	ON	CLAMP	ON (for each AUDIO connector used)	MAIN	270

Decoder Configurations

Table 2-7 ... Table 2-12 provide some basic parameter and connector settings for decoders under three different types of operating conditions.

Quick Start 4: A decoder receiving Artel-270 inputs optically

Table 2-7. I/O Connections: Artel-270 Optical Inputs

INPUT	OUTPUTS					
FC-PC Female Optical Connector	Video BNC Port	Audio Connectors	Data Port	Relays	Test and Analysis Ports	Alarm Relays
OPTICAL INPUT	VIDEO OUTPUT	AUDIO A	RS-232 DATA OUTPUTS	RELAY 1	VIDEO MONITOR	LOCAL MAJOR
		AUDIO B		RELAY 2		LOCAL MINOR
		AUDIO C		RELAY 3	AUDIO MONITOR	REMOTE MAJOR
		AUDIO D		RELAY 4		REMOTE MINOR

Table 2-8. Switch Settings: Artel-270 Optical Inputs

INPUT SELECT	VIDEO SQUELCH	VIDEO COUPLING	Software Change Mode	VIDEO SELECT	MONITOR SOURCE SELECT
OPTICAL	OFF	CLAMP	ANA	MAIN	MAIN



Quick Start 5: A decoder receiving SDI inputs optically

Table 2-9. I/O Connections: SDI Optical Inputs

INPUTS	OUTPUTS		
	Video BNC Port	Test and Analysis Port	Alarm Relays
FC-PC Female Optical Connector			
OPTICAL INPUT	SDI OUTPUT	VIDEO MONITOR	LOCAL MAJOR
			LOCAL MINOR
			REMOTE MAJOR
			REMOTE MINOR

Table 2-10. Switch Settings: SDI Optical Inputs

INPUT SELECT	Software Change Mode	SCRAMBLE	MONITOR SOURCE SELECT
OPTICAL	SDI	Same setting as the SCRAMBLE switch on the encoder	MAIN VIDEO

Quick Start 6: A decoder receiving Artel-270 inputs electrically through a routing switcher

Table 2-11. I/O Connections: Artel-270 Electrical Inputs

Input		Outputs				
Signal BNC Port	Video Port	Audio Connectors	Data Port	Relays	Test and Analysis Ports	Alarm Relays
SDI INPUT	VIDEO OUTPUT	AUDIO A	RS-232 DATA OUTPUTS	RELAY 1	VIDEO MONITOR	LOCAL MAJOR
		AUDIO B		RELAY 2		LOCAL MINOR
		AUDIO C		RELAY 3	AUDIO MONITOR	REMOTE MAJOR
		AUDIO D		RELAY 4		REMOTE MINOR

Table 2-12. Switch Settings: Artel-270 Electrical Inputs

INPUT SELECT	VIDEO SQUELCH	VIDEO COUPLING	Software Change Mode	VIDEO SELECT	DATA RATE MBPS	MONITOR SOURCE SELECT
SDI	OFF	CLAMP	ANA	MAIN	270	MAIN VIDEO

Where to Go Next

Once the DigiLink is installed securely into the equipment cabinet, proceed to [Chapter 3](#) for information on configuring and cabling the encoder. Proceed to [Chapter 4](#) for information on configuring and cabling the decoder.



3

Configuring and Cabling an Encoder

This chapter describes how to configure an encoder using the panel switches and cable ports. The major topics are:

- [Encoder Front and Rear Panel Views \(page 3-2\)](#)
- [Identifying the Unit \(page 3-4\)](#)
- [Applying Power \(page 3-5\)](#)
- [Selecting the Encoder's Operating Mode \(page 3-9\)](#)
- [Establishing Encoder Inputs \(page 3-15\)](#)
- [Establishing Encoder Outputs \(page 3-31\)](#)
- [Using Internal and External Display Capabilities \(page 3-43\)](#)
- [Using the Test Screen Editor \(page 3-54\)](#)

Encoder Front and Rear Panel Views

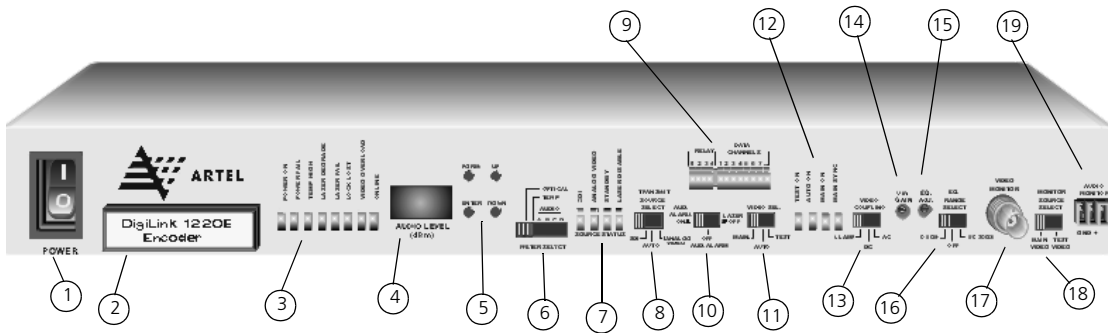

Figure 3-1. Digilink Encoder Front Panel

Table 3-1. Encoder Front Panel Elements

Item	Panel Element	for details, see...
1	POWER switch	page 3-7
2	Encoder model label	page 3-4
3	Status LED indicators	page 3-44
4	AUDIO LEVEL meter display	page 3-50
5	Test Screen editor buttons	page 3-56
6	METER SELECT switch	page 3-50
7	Operating mode LED indicators	page 3-47
8	TRANSMIT SOURCE SELECT switch	page 3-9
9	Relay/Data LED indicators	page 3-48
10	AUDIBLE ALARM/LASER OFF switch	page 3-52
11	Analog VIDEO SELECT switch	page 3-32
12	Signal output LED indicators	page 3-49
13	VIDEO COUPLING switch	page 3-22
14	VIDEO GAIN potentiometer	page 3-19
15	EQUALIZATION ADJUSTMENT potentiometer	page 3-19
16	EQUALIZATION RANGE SELECT switch	page 3-18
17	VIDEO MONITOR port	page 3-40
18	MONITOR SOURCE SELECT switch	page 3-41
19	AUDIO MONITOR port	page 3-42

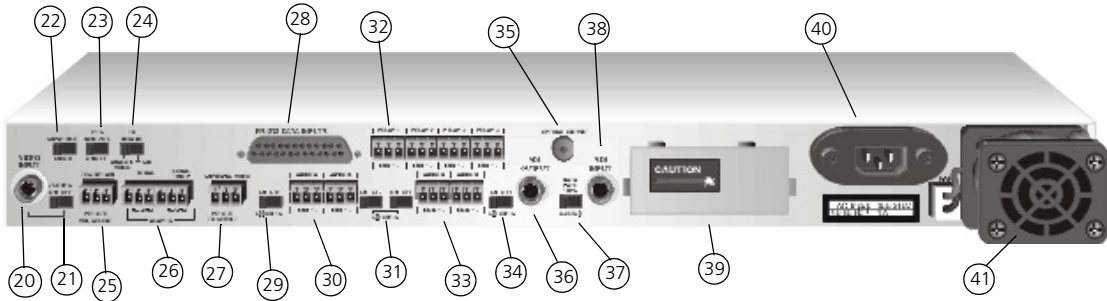

Figure 3-2. DigiLink Encoder Rear Panel

Table 3-2. Encoder Rear Panel Elements

Item	Panel Element	for details, see...
20	VIDEO INPUT port	page 3-16
21	75 OHMS switch (for video termination)	page 3-17
22	SCRAMBLE switch	page 3-29
23	EMS CONTROL switch (not used)	
24	TX DEFAULT switch	page 3-11
25	REMOTE VIDEO SELECT connector	page 3-35
26	ALARM relay connectors	page 3-53
27	REMOTE TX SELECT connector	page 3-12
28	RS-232 DATA INPUTS port	page 3-26
29	600 OHMS switch (for audio channel A)	page 3-25
30	AUDIO A and B INPUT connectors	page 3-23
31	600 OHMS switches (for audio channels B and C)	page 3-25
32	RELAY input connectors	page 3-28
33	AUDIO C and D INPUT connectors	page 3-23
34	600 OHMS switch (for audio channel D)	page 3-25
35	SDI OUTPUT (electrical) port	page 3-38
36	OPTICAL OUTPUT port	page 3-36
37	DATA RATE MBPS switch	page 3-34
38	SDI INPUT port	page 3-29
39	Laser cartridge compartment	page 3-37
40	AC power connector	page 3-4
41	External fan	page 3-7

Identifying the Unit

A label appears in the bezel on the left side of the encoder's front panel, below the Artel logo (see item 2 on [page 3-2](#)).

This label provides the unit's model number and identifies the unit as an encoder.

[Figure 3-3](#) shows a sample label identifying the unit as a DL1220E encoder, which is an encoder equipped with an AC power supply and an NTSC test signal generator.

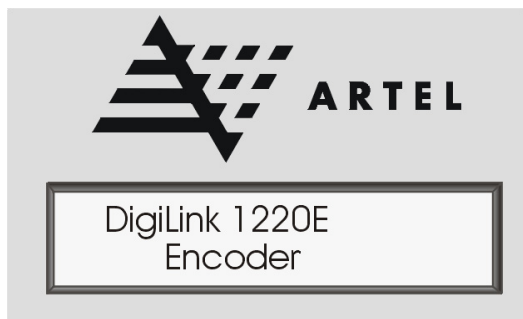

Figure 3-3. An Encoder Label

See [Table 1-2](#) and [Table 1-4](#) for a complete list of DL1200 and DL1220 encoder models.



Applying Power

DigiLink encoders are available with either an AC or DC power supply. Before you install the AC or DC power cord, read [Appendix A](#) for a complete understanding of the system's electrical and environmental specifications.

Connecting an AC Power Cord

The AC connector is located on the encoder's rear panel (item [40](#) on [page 3-3](#)).

The AC connector requires a three-prong IEC 320-C13 115/230 VAC power cord.

To connect an AC power cord to a power source:

1. Make sure that the POWER switch is in the 0 (OFF) position.
2. Lift the cable strain relief and position it above the AC connector.
3. Plug the AC power cord into the power receptacle at the rear of the unit.
4. Lower the cable strain relief to lock in the AC power cord.
5. Plug the power cord into a three-wire grounding receptacle.

Connecting a DC Power Cord

The DC versions of the DigiLink encoders have a -48 VDC input connector terminal block.

Caution

When connecting a DC power supply, make sure that you are connecting the DigiLink to a -48 VDC (-38.4 ... -57.6 VDC) source that is isolated from any AC power and is reliably grounded to earth.

To connect a DC-powered encoder to a power source:

1. Locate the terminal block assembly (1) on the rear of the unit and remove the clip-on protective cover (2) as shown in [Figure 3-4](#).

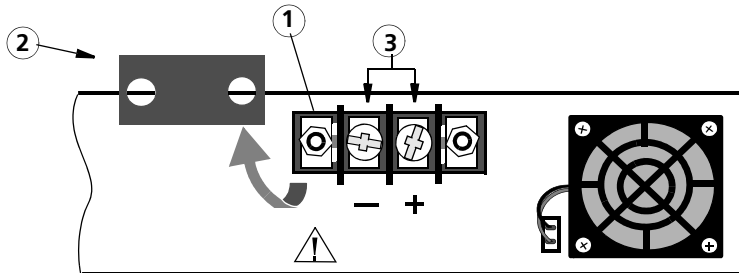

Figure 3-4. DC Power Supply Terminal Block

2. Loosen the two terminal post screws (3) marked - and +.
3. Install the DC power source cables and tighten the screws to secure the connectors to the terminal block. Ensure the spade connector terminations are positioned under the screwheads.

Caution

Before installing the spade connectors, make sure that the polarity of the DC connections is correct. Reversed polarity can blow the DC input fuse and may cause damage to the power supply.

4. Reinstall the protective cover (2) onto the DC terminal block.
5. Connect the other end of the power cable into an approved safety extra low voltage (SELV) energy output source.

Note: Each Digilink encoder consumes approximately 50 W from a nominal 48 VDC circuit. Slow blow (time delay) fusing, such as a T3.15 fuse with a minimum fuse capacity of 2.5 A per encoder, is recommended. If fast blow (fast-acting) fuses are used, a minimum fuse capacity of 10 A per encoder is recommended to prevent nuisance blows.



Powering up the Encoder

Once external power has been connected to the encoder, it can be powered up using the two-position POWER switch on the front panel (item 1 on [page 3-2](#)).



Figure 3-5. Encoder POWER Switch

Toggle the POWER switch to the **1** (ON) position. As the encoder powers up, it initializes and turns on the LEDs briefly.

Once the encoder initializes, you can use the switches on the front and rear panels to configure the encoder and the LEDs to monitor its status.

Cooling the unit (external fan)

The encoder has an external fan on its rear panel (item 41 on [page 3-3](#)) that remains *on* while the unit is under power.

If you are using a laser cartridge:

A thermo-electric cooler in the laser transmitter controls its heating and cooling. When you power up the encoder, it disables laser output for approximately 10 seconds while the laser reaches its proper operating temperature. This feature prevents the unit from transmitting undesired wavelengths onto a network. During this 10 s period, the LASER DEGRADE and LASER FAIL LEDs will illuminate. These LEDs are indicators of major alarm conditions, but they *can* be ignored during this short warm-up period.

Replacing the external fan

Replacing the external cooling fan requires a DL1K-FAN-ED replacement fan, which is available from your Artel customer service representative, and a Phillips screwdriver. This task should be performed by a qualified service person.

Note: The fan replacement procedure can be performed while the encoder is under power.

1. Remove the fan wire connector (1) from its receptacle on the rear of the unit. The connector is a pinch clip that needs to be pushed down for removal.

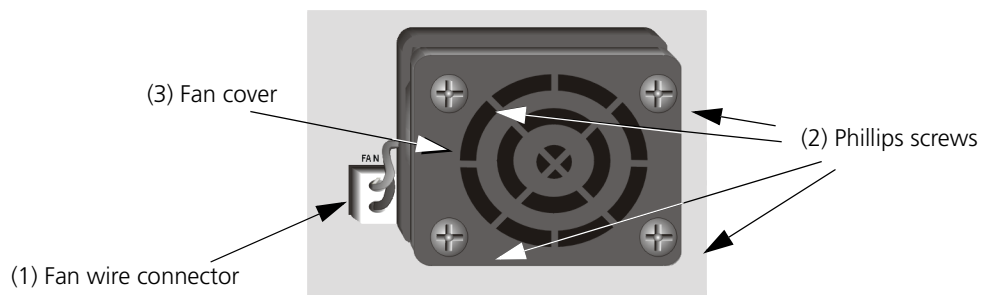

Figure 3-6. Locating the Fan Wire Connector

2. With the Phillips screwdriver, remove the four screws (2) that secure the fan to the unit. Set the screws aside for later use.
3. Remove the fan cover (3) and set it aside for use later.
4. Remove the fan.
5. Align the new DL1K-FAN-ED fan unit with the four screw holes in the chassis.
6. Replace the fan cover and reinsert the four Phillips screws.
7. Plug the new fan wire connector into the receptacle.



Selecting the Encoder's Operating Mode

Overview

The DL1220 encoders can operate in either of two modes—*analog* or *SDI*. A description of these modes is given on [page 1-3](#). The DL1200 encoders do not support SDI mode—they operate only in analog mode.

- Use the TRANSMIT SOURCE SELECT switch ([page 3-9](#)) on a DL1220 encoder to specify its operating mode. This switch has three settings—ANALOG VIDEO, SDI, and AUTO.

When the TRANSMIT SOURCE SELECT switch is set to AUTO, two additional encoder panel hardware elements can be used:

- The TX DEFAULT switch ([page 3-11](#)), which specifies the default operating mode when both analog and digital video input signals are being received simultaneously
- The REMOTE TX SELECT connector ([page 3-12](#)), an optional capability that you can use to set up a remote switching station for controlling the DL1220 encoder's operating mode

Setting the TRANSMIT SOURCE SELECT Switch

Location

The three-position TRANSMIT SOURCE SELECT switch is located on the encoder's front panel (item [8](#) on [page 3-2](#)).

Mode and model restrictions

The switch is functional only on the DL1220 models. It is disabled on the DL1200 encoders, which operate in analog mode all the time regardless of the TRANSMIT SOURCE SELECT switch setting.

Purpose

The TRANSMIT SOURCE SELECT switch is used to specify the operating mode of a DL1220 encoder.

The TRANSMIT SOURCE SELECT switch can be set to ANALOG VIDEO, SDI, or AUTO.

- In the ANALOG VIDEO position, the DL1220 encoder will transmit only in analog mode. If the TRANSMIT SOURCE SELECT switch is set to ANALOG VIDEO and the encoder is not currently receiving an analog video signal on its VIDEO INPUT port ([page 3-16](#)), it will continue to transmit an Artel-270 output signal with audio and data information encoded in it and a test pattern will be sent.
- In the SDI position, the DL1220 encoder will transmit only in SDI mode. If the encoder is not currently receiving a digital signal on its SDI INPUT port, it will transmit a 45 Mbit/s standby signal.
- In the AUTO position, the TRANSMIT SOURCE SELECT switch can serve the following two purposes:
 - a. Enable the encoder to automatically transmit in either analog or SDI mode depending on the type of video input signal it is currently receiving
 - b. Enable the encoder's transmission mode to be controlled remotely via a relay circuit or switch connected to the REMOTE TX SELECT port on the encoder's rear panel

for case a:

When the TRANSMIT SOURCE SELECT switch is in the AUTO position, the DL1220 encoder monitors activity on the ANALOG INPUT and SDI INPUT ports. If an analog signal is being received, it encodes the signal (along with the audio and data inputs it is receiving) into an Artel-270 digital output signal. If a digital signal is being received, the encoder equalizes, re-clocks, and optionally scrambles the input, then transmits it as a digital output. In the event that the encoder senses video signals at both input ports simultaneously, it checks the setting of the TX DEFAULT switch ([page 3-11](#)) and operates in the mode specified by that switch setting.

for case b:

If you want to set up a remote control station in hardware where you can change the encoder's operating mode, set the TRANSMIT SOURCE SELECT switch to the AUTO position and use it in conjunction with the REMOTE TX SELECT relay connector (see [page 3-12](#) for details).

Note: The REMOTE TX SELECT relay connector may or may not be connected to a relay. Do not confuse this connector with the RELAY connectors on the rear panel.



Setting the TX DEFAULT Switch

Location

The two-position TX DEFAULT switch is located on the encoder's rear panel (item 24 on [page 3-3](#)).

Mode and model restrictions

The switch is functional only on DL1220 encoders and only when the TRANSMIT SOURCE SELECT switch ([page 3-9](#)) is set to AUTO. It is disabled on DL1200 encoders, and its setting is ignored by a DL1220 encoder when its TRANSMIT SOURCE SELECT switch is set to ANALOG VIDEO or SDI.

Purpose

When you set the TRANSMIT SOURCE SELECT switch on a DL1220 encoder to AUTO, you must specify a default operating mode for the encoder in the event that both SDI and analog video input signals are present simultaneously. Use the TX DEFAULT switch to specify the default data format—SDI or ANALOG.

When you set the TX DEFAULT switch to SDI:

The DL1220 encoder transmits an SDI output signal whenever it is present:

- If an SDI signal is present and an analog video signal is not present, the encoder transmits the SDI signal
- If both an analog video signal and an SDI signal are present, the encoder transmits the SDI signal
- If an analog video signal is present and an SDI signal is not present, the encoder takes the analog video signal and transmits it in Artel-270 format
- If the encoder is transmitting an Artel-270 signal and then detects the presence of an SDI signal, it automatically stops transmitting the Artel-270 signal and starts transmitting the SDI signal

When you set the TX DEFAULT switch to ANALOG:

The DL1220 encoder encodes an analog signal whenever it is present and transmits it as an Artel-270 output:

- If an analog video signal is present and an SDI signal is not present, the encoder transmits the Artel-270 signal
- If both an analog video signal and an SDI signal are present, the encoder transmits the Artel-270 signal
- If an SDI signal is present and an analog video signal is not present, the encoder transmits the SDI signal
- If the encoder is transmitting an SDI signal and then detects the presence of an analog video input, it automatically stops transmitting the SDI signal, takes the analog video, and transmits it as an Artel-270 signal

Wiring the REMOTE TX SELECT Connector

Location

The three-terminal REMOTE TX SELECT connector is located on the encoder's rear panel (item 27 on [page 3-3](#)).

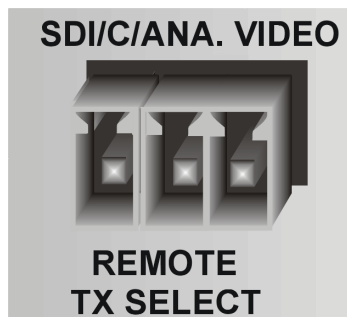

Figure 3-7. Remote TX Select Connector

Mode and model restrictions

The connector is functional only on DL1220 encoders and only when the TRANSMIT SOURCE SELECT switch on the encoder is set to AUTO. It is disabled on DL1200 encoders, and its setting is ignored by a DL1220 encoder when its TRANSMIT SOURCE SELECT switch is set to ANALOG VIDEO or SDI.



Purpose

When the TRANSMIT SOURCE SELECT switch on the DL1220 encoder front panel is set to AUTO, you can control the type of data transmission path (analog or SDI) via hardware from a remote location. Use the REMOTE TX SELECT connector to make the connection between encoder and the remote switching station.

To set up a hardware-based remote TX source select station:

1. Set TRANSMIT SOURCE SELECT switch (DL1220 encoder front panel) to AUTO.
2. Wire the three terminals on the REMOTE TX SELECT connector to an external device such as a single-pole double-throw (SPDT) switch or a relay. Use one of the three-pin removable screw wire clamp connectors shipped with the DigiLink. The connector accepts #24 ... #18 gauge twisted-pair wire.

Once the remote transmit source select station has been set up, use the SPDT switch or relay at the remote station to control the data transmission path as follows:

- When you make a contact closure between C (common) and SDI at your remote switching location, the DL1220 encoder will operate in SDI mode
- When you make a contact closure between C and ANALOG DIGITAL at your remote switching location, the DL1220 encoder will operate in analog mode

Note: When the REMOTE TX SELECT function is enabled, it overrides the TX DEFAULT switch setting ([page 3-11](#)).

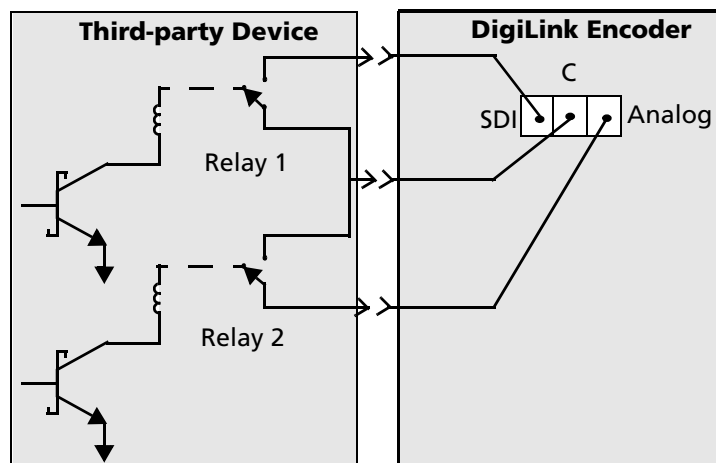

Figure 3-8. Example of a Remote TX Select Connection

Table 3-3. Truth Table for the Remote TX Select Connection Above

When relay 1 is...	and relay 2 is...	The remote switch is...
OFF	OFF	set for AUTO mode
ON	OFF	set for SDI mode
OFF	ON	set for ANALOG mode
ON	ON	set Illegally



Establishing Encoder Inputs

Overview

Analog mode

When the encoder is in analog operating mode, it multiplexes the input signals together as an Artel-270 digital output signal. The inputs can include:

- One analog video signal (for example, as defined in ANSI TI.502-1988) via coaxial cable connected to the VIDEO INPUT port (see [page 3-16](#)). Other analog video formats can also be input to the encoder (e.g., PAL).
- Up to four channels of audio via twisted-pair cable connected to AUDIO INPUTS A ... D (see [page 3-23](#))
- Up to eight channels of data on the RS-232 DATA INPUT port (see [page 3-26](#))
- State data via twisted-pair cable connected to the four relay contacts (see [page 3-28](#))

To configure the inputs for the encoder, you need to set a series of switches that determine internal termination on the video and audio input signals (see [page 3-17](#) and [page 3-25](#), respectively). You also need to specify equalization on the input cables (see [page 3-18](#)) and video coupling on the analog signal (see [page 3-22](#)).

SDI mode

When a DL1220 encoder or decoder is in SDI mode, it is a data-transparent 270 Mb/s transport system. It can transmit/receive a standard 270 Mbit/s serial digital interface signal that complies with SMPTE 259M-C 4:2:2 component signal formats (such as D1 tape) and with ITU 601; in SDI mode, it can also support SMPTE 305M, DVB-ASI, and other related 270 Mb/s services.

In SDI mode, the DL1220 encoder does not add audio or data to the input signal, and it does not perform any encoding on it. It amplifies the digital signal that it has received, optionally adds a scramble pattern (see [page 3-29](#)), and transmits it as an SDI output signal.

Note: Only DL1220 encoders can support SDI mode. A DL1200 encoder does not accept digital input signals.

Analog Video Input

Cabling the VIDEO INPUT Port

Location

The VIDEO INPUT port is a BNC connector located on the encoder's rear panel (item 20 on [page 3-3](#)).

Mode restrictions

In analog mode, a DigiLink encoder uses the signal it receives at the VIDEO INPUT port. Signals received on this port by a DL1220 encoder operating in SDI mode are not transmitted via the encoder's output ports—they may, however, be displayed on the encoder's VIDEO MONITOR port ([page 3-40](#)).

Purpose

The encoder receives broadcast-quality analog baseband video inputs via the VIDEO INPUT port. The input signal is delivered via a coaxial cable using BNC connectors. The BNC connector on the VIDEO INPUT port is isolated from chassis ground to eliminate ground loop-induced noise. Common-mode voltage can be a maximum of ± 20 V (40 V peak-to-peak).

To configure your encoder to receive analog video inputs

1. Use a coaxial cable with a BNC connector on it to bring the analog video signal into the encoder.

Note: For best performance and repeatability, we recommend a high-quality coaxial cable—e.g., Belden type 8281 or equivalent.

2. Connect the input cable to the encoder's VIDEO INPUT port.
3. Make sure the input cable is properly terminated (see [page 3-17](#)).

Note: An improperly terminated input cable may cause video signal clipping, and a video overload alarm may be generated.

If the encoder is not the last device in a series or chain, turn the 75 OHMS terminator switch OFF. Make sure that the last device in the chain is terminated with 75 Ω .



If the encoder is the last device in a chain, turn the 75 OHMS terminator switch ON.

4. Set the VIDEO COUPLING switch ([page 3-22](#)) to the CLAMP position.

Note: When video inputs are present, the MAIN SYNC LED ([page 3-49](#)) goes ON.

Setting the 75 OHMS Termination Switch

Location

The two-position 75 OHMS switch is located on the encoder's rear panel (item [21](#) on [page 3-3](#)).

Mode restrictions

The setting of this switch affects an analog input signal received on the VIDEO INPUT port ([page 3-16](#)) and is important whenever the encoder is operating in analog mode. You should be aware of this switch setting whenever there is a coaxial cable connected to the encoder's VIDEO INPUT port.

It does not affect digital input signals being received by a DL1220 encoder operating in SDI mode.

Purpose

The 75 OHMS switch enables or disables 75 Ω of internal termination on the analog signal coming into the encoder's VIDEO INPUT port.

- In the ON position, the 75 OHMS switch provides 75 Ω of internal termination for the analog video input signal.
- In the OFF position, the 75 OHMS switch provides 4 k Ω of internal impedance for the analog input signal.

Note: When the encoder is the last device in a series or chain, the video input must be terminated with 75 Ω . If it is not the last device, turn this switch OFF.

By way of example, see the discussion of automatic protection configurations on [page 5-7](#). In this example, encoder B is the last device in the chain, and its 75 OHMS switch is ON. Encoder A is not the last device in the chain, and its 75 OHMS switch is OFF.

Setting the EQUALIZATION RANGE SELECT Switch

Location

The three-position EQUALIZATION RANGE SELECT switch is located on the encoder's front panel (item [16](#) on [page 3-2](#)).

Mode restrictions

The setting of this switch affects an analog input signal received on the VIDEO INPUT port ([page 3-16](#)) and is important whenever an encoder is operating in analog mode. You should be aware of this switch setting whenever there is a coaxial cable connected to the encoder's VIDEO INPUT port.

It does not affect digital input signals being received by a DL1220 encoder operating in SDI mode.

Purpose

Use the EQUALIZATION RANGE SELECT switch to equalize the high frequency (HF) loss present on the incoming signal. This switch setting specifies the appropriate cable equalization parameter for the coaxial cable that delivers the analog input signal to the encoder. Choose a setting based on the length of the coaxial input cable:

- Set the switch in the 0-50M position when your coaxial cable is ≤ 50 m (≤ 164 ft)
- Set the switch in the OFF position when no cable equalization is desired—e.g., if the cable is being equalized somewhere else in the system outside the encoder
- Set the switch in the 50-300M position when your coaxial cable is > 50 m (> 164 ft)

If your selection is either 0-50M or 50-300M, use the EQUALIZATION ADJUSTMENT potentiometer ([page 3-19](#)) to control the amount of cable equalization.



Adjusting the VIDEO GAIN and EQUALIZATION ADJUSTMENT Potentiometers

Location

VIDEO GAIN and EQUALIZATION ADJUSTMENT potentiometers are located on the encoder's front panel (items [14](#) and [15](#), respectively, on [page 3-2](#)).

Mode restrictions

These potentiometers affect an analog input signal and are important whenever an encoder is operating in analog mode. They do not affect digital input signals being received by a DL1220 encoder operating in SDI mode.

Purpose

- The VIDEO GAIN potentiometer enables you to adjust the input level of an analog video signal by ± 3 dB for 100 IRE.
- The EQUALIZATION ADJUSTMENT potentiometer equalizes the input signal coming into the VIDEO INPUT port ([page 3-16](#)). The cable should be a Belden 8281 or equivalent, which can be equalized for up to 300 m (984 ft) at 75 Ω .

The EQUALIZATION ADJUSTMENT potentiometer is used in conjunction with the EQUALIZATION RANGE SELECT switch when the switch is set to either 0-50M or 50-300M. When this switch is OFF, the potentiometer does not function.

To make video gain and cable equalization adjustments:

1. Connect a source video cable to the VIDEO INPUT port's BNC connector (according to the procedure on [page 3-16](#)).
2. Make sure the 75 OHMS switch is turned ON.
3. Connect a calibrated video waveform monitor or vector scope terminated with 75 Ω to the VIDEO MONITOR port ([page 3-40](#)).
4. Set the MONITOR SOURCE SELECT switch ([page 3-41](#)) to MAIN VIDEO.
5. Set the VIDEO SELECT switch ([page 3-32](#)) to MAIN.
6. Connect a test pattern generator with a multi-burst test pattern to the source end of the video cable. [Figure 3-9](#) illustrates a multi-burst video test pattern.

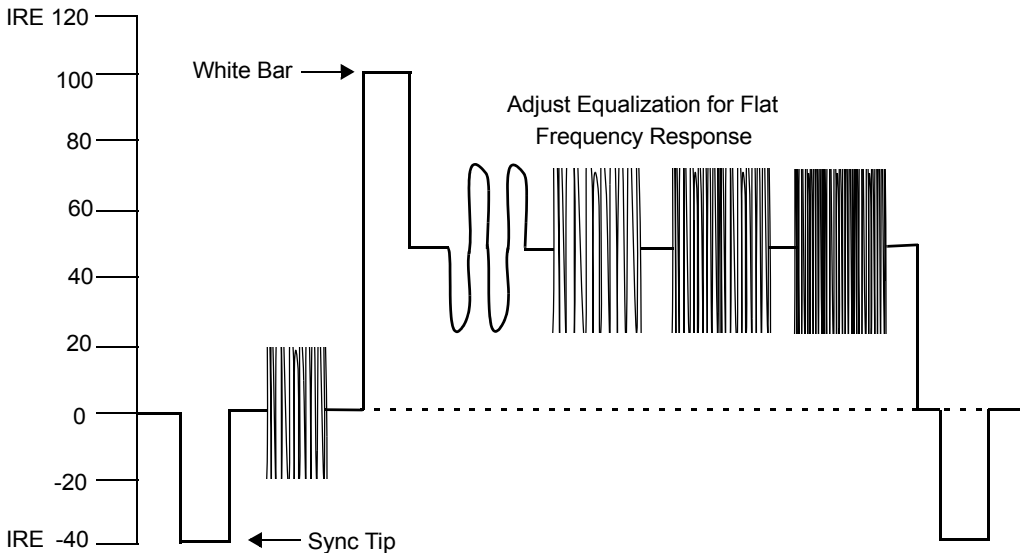

Figure 3-9. Multi-Burst Video Test Pattern



7. Set the cable equalization appropriately:
 - If cable equalization is not required at the device level, set the front panel EQUALIZATION RANGE SELECT switch to OFF.
 - If the cable is 50 m (164 ft) or less, set the front panel EQUALIZATION RANGE SELECT switch to 0-50M, then turn the EQUALIZATION ADJUSTMENT potentiometer until the signal attains a flat frequency response—i.e., until all the frequency bursts are of the same amplitude.
 - If the cable is longer than 50 m (164 ft), set the EQUALIZATION RANGE SELECT switch to 50-300M, then turn the EQUALIZATION ADJUSTMENT potentiometer until the signal attains a flat frequency response—i.e., until all the frequency bursts are of the same amplitude.

Note: To decrease the amount of cable equalization, turn the EQUALIZATION ADJUSTMENT potentiometer counterclockwise. To increase the amount of cable equalization, turn the EQUALIZATION ADJUSTMENT potentiometer clockwise.

8. Adjust the VIDEO GAIN potentiometer for 1 V peak-to-peak from sync tip to white bar (measured at the VIDEO MONITOR port).

Note: To increase the signal level, turn the VIDEO GAIN potentiometer clockwise. To decrease the signal level, turn the VIDEO GAIN potentiometer counterclockwise.

Setting the VIDEO COUPLING Switch

Location

The three-position VIDEO COUPLING switch is located on the encoder's front panel (item 13 on [page 3-2](#)).

Mode and model restrictions

The setting of this switch affects an analog input signal received on the VIDEO INPUT port ([page 3-16](#)) and is important whenever an encoder is operating in analog mode. You should be aware of this switch setting whenever there is a coaxial cable connected to the encoder's VIDEO INPUT port.

It does not affect digital input signals being received by a DL1220 encoder operating in SDI mode.

Purpose

Use the VIDEO COUPLING switch to AC-couple, DC-couple, or clamp the analog video input signal.

The analog input should be AC-coupled for:

Signals that may contain a non-functional DC component—e.g., telephony or clock signals such as T1, DS1, DS1C, E1, T2, and E2 that do not contain a long-term DC component.

When the VIDEO COUPLING switch is set to the AC position, the input voltage range measured at the MONITOR port should be adjusted by the VIDEO GAIN potentiometer so the input voltage range is no more than 1.4 V PP when the 75 OHMS internal termination switch ([page 3-17](#)) is ON.

The analog input should be clamped for:

Normal video signals (such as NTSC or PAL signals) that contain a standard -40 IRE (or similar) sync pulse.

When the VIDEO COUPLING switch is set to the CLAMP position, the clamp circuit corrects for ± 1 V of differential offset in the incoming signal (at nominal gain settings).

**The analog input should be DC-coupled for:**

- Preservation of DC level
- Video signals that do not contain a standard -40 IRE sync pulse, e.g., radar signals and certain scrambled signals.

When the switch is set to the DC position, the input voltage range measured at the MONITOR port is ± 0.7 V when the 75 OHMS switch is ON.

Caution

Do not AC-couple or DC-couple a normal (NTSC or PAL) video signal. DC coupling a normal signal can cause an *overload* condition. Set the VIDEO COUPLING switch to CLAMP when you are using normal NTSC or PAL inputs.

AUDIO INPUTS**Location**

Four three-terminal AUDIO INPUT connectors (AUDIO A, B, C, and D) are located on the encoder's rear panel (items [30](#), [31](#), and [34](#) on [page 3-3](#)).

Mode restrictions

These connectors provide audio inputs to a DigiLink encoder operating in analog mode. In SDI mode, a DL1220 encoder cannot multiplex audio (or data) into its output signal.

Purpose

Audio channel information is input to the encoder at these AUDIO INPUT connectors and embedded into the Artel-270 output signal when the encoder is operating in analog mode.

Each AUDIO INPUT connector provides a balanced two-wire plus shield connection.

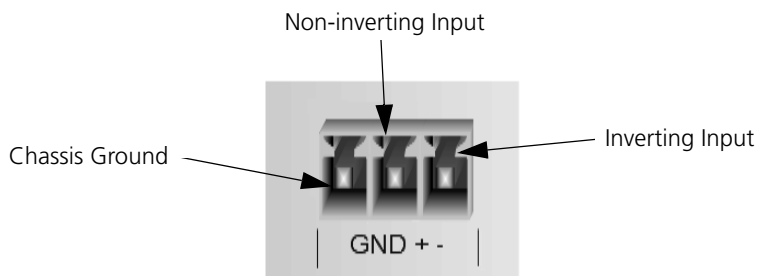

Figure 3-10. An AUDIO INPUT Connector

To set your encoder up to receive audio inputs

1. Use #24 ... #18 gauge twisted-pair wire to deliver the audio input signals to the AUDIO INPUT connectors.

Note: For best performance, we recommend shielded twisted-pair cable. If you use multi-pair cable, make sure that each pair is shielded separately to maintain signal quality and minimize noise and crosstalk.

2. To eliminate ground loops, ground the shields at one end of the cable only. We recommend grounding the shields at the driven (source) end of the cable.
3. Make sure the input wires are properly terminated. A set of 600 Ω terminator switches is provided (see [page 3-25](#)).



Setting the Audio 600 OHMS Switches

Location

Four two-position 600 OHMS audio terminator switches are located on the encoder's rear panel (items 29, 31, and 34 on page 3-3). Each switch is associated with one of the audio channel ports. Figure 3-11 shows the locations of each switch with respect to the audio channel connector it supports.

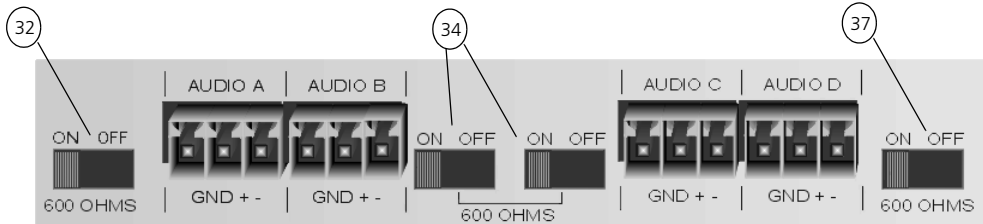

Figure 3-11. Terminator Switch-Audio Port Relationship

- The switch to the left of the AUDIO A connector (item 29) works with audio channel A
- The switch to the right of the AUDIO B connector (the left switch in item 31) works with audio channel B
- The switch to the left of the AUDIO C connector (the right switch in item 31) works with audio channel C
- The switch to the right of the AUDIO D connector (item 34) works with audio channel D

Mode restrictions

The settings of these switches affect input signals received on the AUDIO INPUT connectors (page 3-23). They are important whenever an encoder is operating in analog mode.

They do not affect digital input signals being received by a DL1220 encoder operating in SDI mode.

Purpose

These switches enable or disable internal termination for the audio channel input signals. They are functional when the encoder is operating in analog mode and is embedding audio channel information into the Artel-270 signal.

- Turning ON a 600 OHM switch internally terminates the associated audio channel with 600 Ω of impedance.
- When a 600 OHMS switch is OFF, the encoder provides 53 k Ω of internal input impedance to the associated audio channel.

Unlike video, the audio input does not need to be terminated to operate. Generally, the audio signals are terminated with 600 Ω unless the source signal requires otherwise. If the encoder is being used in a chain and is not the last device in the chain, the 600 OHMS switch must be turned OFF.

For optimum performance, match the encoder audio impedance with the audio source impedance.

Data Inputs

Cabling the RS-232 DATA INPUTS Port

Location

The RS-232 DATA INPUTS port is a 25-pin D-shell connector located on the encoder's rear panel (item 28 on [page 3-3](#)).

Mode restrictions

This port provides data inputs to a DigiLink encoder operating in analog mode. In SDI mode, a DL1220 encoder cannot multiplex data into its output signal.



Purpose

The RS-232 DATA INPUTS port provides eight simplex data channels that can be encoded and transmitted in the Artel-270 signal when the encoder is transmitting in analog mode. The port pinouts are as follows:

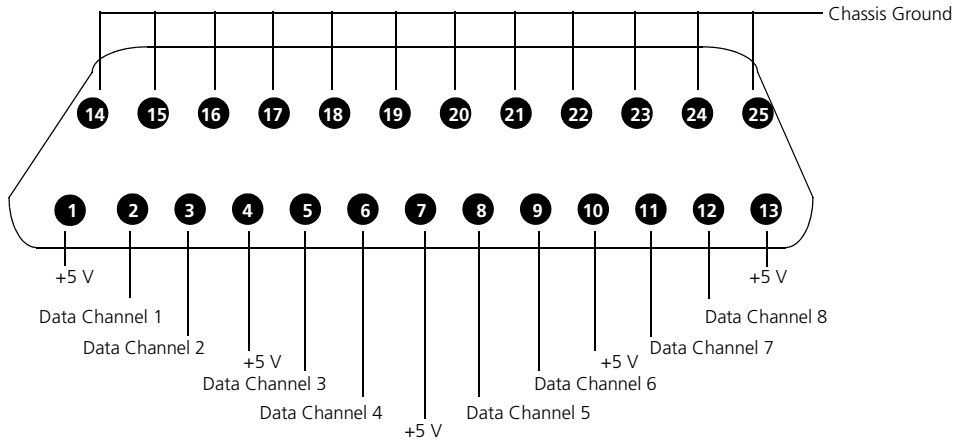

Figure 3-12. Pinouts for the RS-232 DATA INPUTS Port

The +5 V pins enable you to bias one or more of the data channels to the HI or MARK state. Total short circuit output current for the +5 V pins is limited to 15 mA.

Note: The RS-232 port on an encoder is for inputs only, and data transmission is in one direction. If you have a bidirectional DigiLink installation, you can transmit RS-232 duplex data.

Data transmission rates from DC to 19.2 kbit/s are allowed. The data channels are baud- and protocol-transparent—i.e., no switch settings are required and all channels are independent.

Activity on the DATA INPUTS port is indicated by the DATA CHANNELS LEDs ([page 3-48](#)).

Wiring the RELAY Input Connectors

Location

Four three-terminal RELAY contact closures (RELAY 1 ... RELAY 4) are located on the rear panel of the encoder (item 32 on [page 3-3](#)).

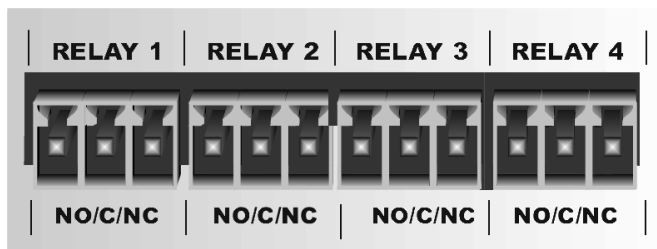

Figure 3-13. RELAY INPUT Connectors

Mode restrictions

These connectors provide control data inputs to a DigiLink encoder operating in analog mode. In SDI mode, a DL1220 encoder cannot multiplex control data into its output signal.

Purpose

The states of the relays can be encoded and transmitted as control data in the Artel-270 signal when the encoder is in analog mode.

A contact closure across the + and - pins can be transmitted to the decoder and cause a contact closure at the decoder end. This mechanism allows the encoder to control an external device connected to the decoder.

The inputs have a maximum open-circuit voltage of 24 VDC. The short circuit input current is less than 1 mA. Common-mode input voltage is limited to ± 12 VDC relative to chassis ground.

To connect a RELAY connector to an external device

Use one of the three-pin removable screw wire clamp connectors shipped with the DigiLink. The RELAY connectors accept #24 ... #18 gauge twisted-pair wire.

Activity on the RELAY input connectors is indicated by the RELAY LEDs ([page 3-48](#)).



Digital Video Input

Cabling the SDI INPUT Port

Location

The SDI INPUT port is a BNC connector located on the rear panel of the encoder (item [38](#) on [page 3-3](#)).

Mode and model restrictions

The SDI INPUT port provides digital inputs for a DL1220 encoder operating in SDI mode. In analog mode, a DL1220 encoder cannot use digital inputs. The DL1200 encoders do not support SDI mode. The SDI INPUT port is present but disabled on these encoders.

Purpose

When a DL1220 encoder or decoder is in SDI mode, it is a data-transparent 270 Mb/s transport system that can transmit/receive a standard 270 Mbit/s serial digital interface signal. The SDI signal must conform to SMPTE 259M-C 4:2:2 component signal format, SMPTE 305M, DVB-ASI, or another related 270 Mb/s services.

The encoder equalizes, reclocks, and optionally scrambles the digital input signal, then transmits it optically via the OPTICAL OUTPUT port or electrically via the SDI OUTPUT port.

The encoder cannot multiplex additional audio or data in an SDI signal, and it cannot encode it as an Artel-270 signal.

Using the SCRAMBLE Switch

Location

The two-position SCRAMBLE switch is located on the encoder's rear panel (item [22](#) on [page 3-3](#)).

Mode and model restrictions

This switch is functional only on a DL1220 encoder operating in SDI mode; it is not functional when the encoder is in analog mode. The switch is present but disabled on the DL1200 encoders.

Purpose

- In the ON position, the SCRAMBLE switch enables an Artel-proprietary algorithm that scrambles the SDI signal
- In the OFF position, the SCRAMBLE switch disables the scramble algorithm and causes the SDI signal to be transmitted unscrambled

Note: You can pass the scrambled signal through non-Artel SDI devices along the path to the destination decoder without affecting the integrity of the signal. However, because the scrambling algorithm is proprietary, you must use a DL1220 decoder to descramble a scrambled SDI signal at its destination.

If you are using a DL1220 encoder in SDI mode and want to output the signal to a non-Artel destination device, you must turn the SCRAMBLE switch OFF.

Scrambling the signal in the encoder helps to ensure proper data recovery and data integrity when it is descrambled at the decoder end. Scrambling the SDI signal may also be useful when the DigiLink signal is being passed through a non-Artel repeater that has trouble with low-transition density signals. The scrambled signal is also a useful security tool.

Note: The scrambling algorithm is built into the Artel-270 format. Therefore, an analog signal is always scrambled when it gets encoded by a DigiLink encoder. The SCRAMBLE switch setting is ignored when the encoder is operating in analog mode.

Note: If you are using an Artel-270 signal as the SDI input to the encoder, make sure that the SCRAMBLE switch is turned OFF. The Artel-270 signal has already been scrambled prior to being sent to the encoder.



Establishing Encoder Outputs

Overview

An encoder can provide a digitally encoded signal and a test screen as outputs (see [page 3-40](#)). The output destination can be a decoder on the opposite end of the communication link or a device connected to the encoder's VIDEO MONITOR port.

Video signal outputs

A video signal output may be transmitted to the decoder either optically via an optical output port ([page 3-36](#)) or electrically via the SDI OUTPUT port ([page 3-38](#)).

- Optical transmission requires use of an encoder with a built-in laser or an installed optional laser cartridge
- The SDI OUTPUT port is provided on all encoders to support electrical transmission

The encoder is able to send a copy of the video output to an attached monitor when the video output is an Artel-270 signal encoded from an analog video input.

Note: An SDI signal cannot be output from the monitor port. However, you can monitor an SDI input signal by connecting an SDI monitor to the SDI OUTPUT port.

Test screen output

The encoder has an installed default test pattern.

You can send this default test pattern:

- As an output to a decoder when the encoder is operating in *analog* mode
- To a monitor display (in analog mode or SDI mode)

You can also customize a test screen by changing the pattern background and adding or editing text (see [page 3-54](#)).

Selecting a Video Output Signal

Setting the VIDEO SELECT Switch

Location

The three-position analog VIDEO SELECT switch is located on the encoder's front panel (item 11 on [page 3-2](#)).

Mode restrictions

This switch applies to signals to be transmitted from the encoder's output port(s) when the encoder is operating in analog mode.

You need to be aware of this switch setting whenever there is a coaxial cable connected to the encoder's VIDEO INPUT port. The switch setting can affect the monitor display ([page 3-41](#)) even when the encoder is operating in SDI mode.

Purpose

Use the VIDEO SELECT switch to specify whether the encoder will transmit the main video signal or a test screen to the output port(s) when the encoder is operating in analog mode.

- When the switch is set to MAIN, the encoder sends an Artel-270 output signal to one or more of the encoder's output ports
- When the switch is set to TEST, the encoder sends a test screen to one or more of the encoder's output ports
- When the switch is set to AUTO, the encoder will transmit the main video signal when it is available and a test screen when the main video is not available

The output port may be:

- The encoder's OPTICAL OUTPUT port ([page 3-36](#))
- The optical output port on a laser cartridge ([page 3-37](#))
- The encoder's SDI (electrical) OUTPUT port ([page 3-38](#))

**When the VIDEO SELECT switch is in the MAIN position:**

If the video signal is not available, the encoder can still transmit the Artel-270 signal with audio and data components encoded in it.

If the MONITOR SOURCE SELECT switch ([page 3-41](#)) is also set to MAIN VIDEO, you get a copy of the analog input signal (if one is present on the input BNC connector) prior to its A/D conversion.

When the VIDEO SELECT switch is in the AUTO position:

The encoder outputs the main video signal to one or more output ports whenever it is available. If the main video input signal is lost, the encoder outputs the test screen until the main video becomes available again.

In the AUTO position, the switch can also work in conjunction with the REMOTE VIDEO SELECT connector ([page 3-35](#)) to configure a remote switching station in hardware from which you can switch the output signal between MAIN and TEST.

When the VIDEO SELECT switch is in the TEST position:

The encoder constantly outputs a test screen to one or more of the encoder's output ports. The test screen may be either the default screen provided with the device or one that has been customized with the Test Screen editor ([page 3-63](#)).

Setting the DATA RATE MBPS Switch

Location

The two-position DATA RATE MBPS switch is located on the encoder's rear panel (item [37](#) on [page 3-3](#)).

Mode restrictions

The switch options apply only to an encoder operating in analog mode. If you are using a DL1220 encoder operating in SDI mode, make sure that the switch is set to 270.

Purpose

The DATA RATE MBPS switch is used to specify the rate at which the encoder will transmit the Artel-270 signal it has encoded.

Selectable data rate for the encoder may be set to either 269.5 Mbit/s or 270 Mbit/s.

Please note the following guidelines:

- Put the DATA RATE MBPS switch in the 269.5 position whenever the encoder is transmitting an Artel-270 signal to an older Artel decoder.
- You may transmit an Artel-270 signal to a current model Artel decoder with the switch in either the 269.5 or 270 position.

Note: An older model decoder can be distinguished from a current one by the type of LED display it has.

Older model decoders have a bar graph LED display.

Current model decoders have the LED display type illustrated in [Figure 3-1 on page 3-2](#).

- Data rate for DL1280 Repeater connections must be 269.5 Mbit/s
- Data rate for DL1290 Repeater connections must be 270 Mbit/s.
- If you are using a UTAH Routing Switcher or an equivalent third-party digital switch between the DigiLink encoder and decoder, you must put the DATA RATE MBPS switch in the 270 position.



Wiring the REMOTE VIDEO SELECT Connector

Location

The three-terminal REMOTE VIDEO SELECT connector is located on the encoder's rear panel (item 25 on [page 3-3](#)).

Mode restrictions

This connector affects the signal transmission when the encoder is operating in analog mode. If you are using a DL1220 encoder operating in SDI mode, this connector has no effect on the signal transmission.

Purpose

When the VIDEO SELECT switch ([page 3-32](#)) is set to AUTO, you are able to control the type of signal (main video or test pattern) being sent to the output port(s) via hardware from a remote location. Use the REMOTE VIDEO SELECT connector to make the connection between encoder and the remote switching station.

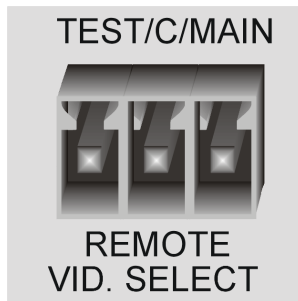

Figure 3-14. REMOTE VIDEO SELECT Connector

To set up a hardware-based remote video select station:

- Set the VIDEO SELECT switch on the encoder front panel to AUTO. If the VIDEO SELECT switch is set to MAIN or TEST, the remote control will not function.
- Wire the three terminals on the REMOTE VIDEO SELECT connector to an external device such as a single-pole double-throw (SPDT) switch or a relay. Use one of the three-pin removable screw wire clamp connectors shipped with the DigiLink. The connector accepts #24 ... #18 gauge twisted-pair wire.

Selecting the video output remotely

Once the remote video select switching station has been set up, use the SPDT switch or relay at the remote station to control the video output type.

- When you make a contact closure between C (common) and MAIN at your remote switching location, the encoder will output the main video signal.
- When you make a contact closure between C (common) and TEST at your remote switching location, the encoder will output the test pattern.

Cabling the OPTICAL OUTPUT Port

Location

The OPTICAL OUTPUT port is an FC-PC female optical connector located on the rear panel of the encoder (item [36](#) on [page 3-3](#)).

Model restrictions

An OPTICAL OUTPUT port is available on all DigiLink encoders that have a built-in laser (1310 or 1550 nm).

An OPTICAL OUTPUT connector is not provided on encoders that do not have a built-in laser.

Purpose

The encoder uses the OPTICAL OUTPUT port to transmit Artel-270 or SDI signals optically over a single fiber cable whenever the signals are pulsed by the built-in laser. The port is designed to operate with a 9 μm singlemode optical fiber cable.

**To install a fiber optic cable on the OPTICAL OUTPUT port:**

1. Remove the protective plastic cap from the connector.

Caution

When the OPTICAL OUTPUT port is not connected to a fiber cable, cover the connector with the protective plastic cap. The cap prevents degradation of optical performance that dirt and moisture can cause.

2. Use a fiber optic cable with a male FC-PC connector on it. Insert the cable connector into the OPTICAL OUTPUT connector and turn it until the keys mate.

Note: FC-PC connectors are keyed and can only be mated at one radial orientation.

3. Push in the connector and tighten it.

Note: Use care when moving or installing an encoder that has a fiber cable attached to the connector. To avoid sharp bends, kinks, or twists in the optical cables, remove the cable before moving an encoder.

Using a Laser Cartridge**Location**

A laser cartridge is an option that can be inserted into the compartment on the encoder's rear panel (item 39 on [page 3-3](#)). For more information about Artel's offering of laser cartridges, refer to [page 1-7](#).

Model restrictions

All DigiLink encoder models accept an optional laser cartridge. If you use a DL1200EN or DL1220EN model encoder (which do not have a built-in laser) with a laser cartridge installed, the laser cartridge gives you the ability to transmit the output signal optically.

With a cartridge installed, the DL1200EN encoders can transmit optically in analog mode, and the DL1220EN encoders can transmit optically in either analog or SDI mode.

Purpose

Once a laser cartridge has been inserted, the encoder is able to transmit optical signals via the optical output connector resident on the cartridge assembly.

If your encoder has a built-in 1310 or 1550 nm laser and a laser cartridge installed in it as well, both the OPTICAL OUTPUT connector and the laser cartridge optical output connector are functional.

For laser cartridge information and installation instructions, refer to [page B-4](#).

When two lasers are present

Both optical output ports are always active and capable of transmitting an output signal (even when a fiber optic cable is not attached).

Note the following guidelines:

- Fiber cables may be connected to either or both ports.
- If both optical ports are attached to separate fiber optic cables, the encoder will generate the signal with both lasers and transmit the signal on redundant fiber paths.
- If the fiber optic cable is connected to the OPTICAL OUTPUT port on the encoder's rear panel and you want to transmit only the signal generated by the laser in the cartridge, disconnect the fiber optic cable and reconnect it to the optical port on the laser cartridge.
- If the fiber optic cable is connected to the optical port on the laser cartridge and you want to transmit only the signal generated by the built-in laser, disconnect the fiber optic cable and reconnect it to the OPTICAL OUTPUT port on the encoder's rear panel.

Cabling the SDI OUTPUT Port

Location

The SDI OUTPUT port is a BNC connector located on the encoder's rear panel (item [35](#) on [page 3-3](#)).

**Purpose**

The encoder uses the SDI OUTPUT port whenever it is sending an electrical transmission over a coaxial cable. The port is used for electrical transmission regardless of whether the encoder is operating in analog or SDI mode.

The encoder can transmit an output signal up to 250 m (820 ft) over the SDI OUTPUT port. The destination device may be a decoder or a digital switch such as a Utah Routing Switcher.

Termination should be applied as appropriate on the destination end of the link.

Note: For best performance and repeatability, we recommend a high-quality coaxial cable (Belden type 8281 or equivalent). For short cable lengths of less than 10 m (33 ft), you may use other cable types and impedances with little impact on performance.

Monitoring Video and Audio Signals

Wiring the VIDEO MONITOR Port

Location

The VIDEO MONITOR port is a BNC connector located on the encoder's front panel (item 17 on [page 3-2](#)).

Mode restrictions

Video from an Artel-270 signal may be sent to the VIDEO MONITOR port, but an SDI video signal cannot be sent to the VIDEO MONITOR port. If the encoder is operating in SDI mode and the monitor is displaying a main video signal, the video sent to the monitor is not the same signal that the encoder is transmitting from its output port.

Purpose

Use this port to connect an external device such as a waveform analyzer, a vector scope, or the appropriate NTSC or PAL video monitor to the encoder.

Note: For accurate measurements, terminate the signal with 75 Ω .

You can display either the main video signal or a test screen on the VIDEO MONITOR port—use the MONITOR SOURCE SELECT switch ([page 3-41](#)) to specify the type of signal you want sent to the port. If you want to send main video, you also need to configure the VIDEO SELECT switch ([page 3-32](#)) appropriately.

Note: If you are using a DL1220 encoder in SDI mode and are outputting the SDI signal over the OPTICAL OUTPUT port ([page 3-36](#)), you can connect a video monitor to the SDI OUTPUT port ([page 3-38](#)) and use it to monitor digital video.



Setting the MONITOR SOURCE SELECT Switch

Location

The two-position MONITOR SOURCE SELECT switch is located on the encoder's front panel (item 18 on [page 3-2](#)).

Purpose

Use this switch to specify the kind of signal that the encoder will send to its VIDEO MONITOR port—either the video from an Artel-270 output signal or a test screen. In order to receive main video at the MONITOR port, the VIDEO SELECT switch ([page 3-32](#)) must be set so for the encoder to send MAIN video.

Note: If you are using a DL1220 encoder in SDI mode and are outputting the SDI signal over the OPTICAL OUTPUT port ([page 3-36](#)), you can connect a video monitor to the SDI OUTPUT port ([page 3-38](#)) and use it to monitor digital video.

When the MONITOR SOURCE SELECT switch is set to MAIN VIDEO:

The encoder sends the main video signal to the VIDEO MONITOR port whenever it is available. Main video is available when both of the following conditions are met:

- The VIDEO SELECT switch ([page 3-32](#)) is set to MAIN or AUTO
- There is a video input signal coming into the encoder's VIDEO INPUT port

If the main video is not available, the encoder sends a test screen to the VIDEO MONITOR port.

When the MONITOR SOURCE SELECT switch is set to TEST VIDEO:

The encoder constantly sends a test screen to the VIDEO MONITOR port. The test screen may be the default screen provided with the encoder or a custom screen you have developed with the Test Screen editor ([page 3-63](#)).

Wiring the AUDIO MONITOR Connector

Location

The three-terminal AUDIO MONITOR connector is located on the encoder's front panel (item 19 on [page 3-2](#)).

Mode restrictions

Audio inputs can be encoded into the Digilink transmission signal only when the encoder is operating in analog mode. A DL1220 encoder operating in SDI mode cannot add audio information to the transmission signal. If you are receiving audio inputs but outputting an SDI signal, the audio you monitor via this port is not part of the output signal.

Purpose

This port allows you to connect an external audio analyzer to the encoder. Use the METER SOURCE SELECT switch ([page 3-50](#)) to specify the audio channel (A, B, C, or D) that you want to analyze.

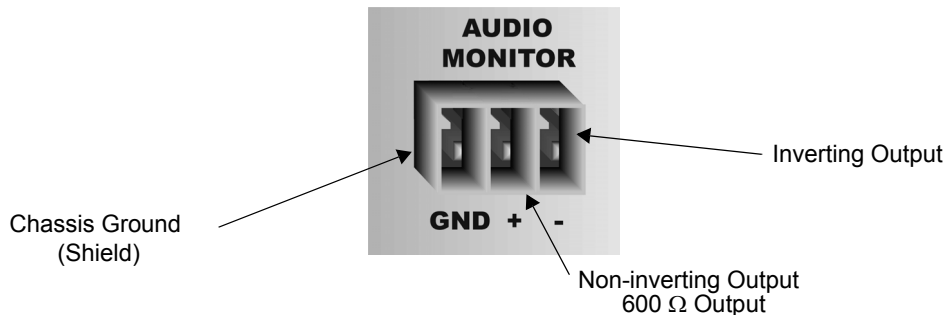

Figure 3-15. Encoder Front Panel Audio Monitor Connector

For accurate measurements, terminate the wire attached to the audio channel connector being analyzed with 600 Ω ([page 3-25](#)).



Using Internal and External Display Capabilities

Overview

Internal mechanisms

The encoder contains four on-board mechanisms that provide status information and alarm conditions:

- LEDs (see [page 3-44](#))
- The AUDIO LEVEL meter display (see [page 3-50](#))
- An audible alarm (see [page 3-52](#))

The LEDs on the front panel provide indications of operating status, operating mode, relay and data input availability, and output status.

The AUDIO LEVEL display is used in conjunction with the METER SELECT switch. Together they let you display status information about the encoder's optical wavelength, its internal operating temperature, and its audio input channels.

A built-in buzzer can be configured to sound whenever a major alarm condition is detected.

Optional external devices

A pair of relays (see [page 3-53](#)) is also provided so that you can send major and/or minor alarm detection information to an external display.

Two monitor ports are also provided:

- A VIDEO MONITOR port (see [page 3-40](#))
- An AUDIO MONITOR port (see [page 3-42](#))

You can connect external display and analysis tools to the encoder via these ports.

Interpreting the Encoder LEDs

Location

The DigiLink encoder's front panel contains four groups of light-emitting diode (LED) indicators:

- A group of eight *device status* LEDs (item 3 on page 3-2)
- A group of four *source status* LEDs (item 7 on page 3-2)
- A group of 12 *relay/data* LEDs (item 9 on page 3-2)
- A group of four *output status* LEDs (item 12 on page 3-2)

The device status LEDs indicate:

- When the encoder power is on
- When an alarm condition has been detected
- When the encoder is enabled and is transmitting valid data

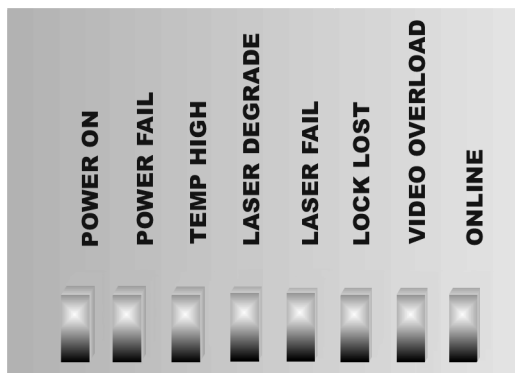

Figure 3-16. Device Status LEDs

Table 3-4 describes their indications and the recommended response.

**Table 3-4. Device Status LEDs**

Name	Color	State	Indication	Alarm Condition
POWER ON	Green	On	Main power is on	None
POWER FAIL	Red	On	One or more of the DC system voltages is out of tolerance	Major—unit must be serviced.
TEMP HIGH	Red	On	Internal system temperature limit has been exceeded	Minor—possible causes: <ul style="list-style-type: none">• Fan failure• Ambient temperature too high• Poor air circulation
LASER DEGRADE	Yellow	On	Bias current required to maintain the laser diode optical output power has increased beyond a preset limit.*	Minor—transmitter is still functional, but laser diode may be nearing end of life. Laser repair is recommended.
LASER FAIL	Red	On	Laser diode optical output power has decreased by more than 1.25 dB below initial value; may have failed completely.*	Major—affects the functionality of the encoder. Laser must be repaired.
* The DL1200EN and DL1220EN models, which do not have built-in lasers, can sense a LASER DEGRADE or LASER FAIL condition if a laser cartridge has been installed. If no cartridge has been installed, these LEDs are nonfunctional.				
LOCK LOST	Red	On	Optical transmitter unable to lock its high speed bit clock to the video (sample) clock	Major—affects the functionality of the encoder. Laser diode transmitter is disabled, and unit must be repaired.

Name	Color	State	Indication	Alarm Condition
VIDEO OVERLOAD	Red	On	Amplitude of video signal being encoded is overloading the A/D converter	Possible causes: <ul style="list-style-type: none"> • VIDEO COUPLING switch was set to AC or DC—set it to CLAMP • VIDEO INPUT cable not terminated properly. (Turn 75 Ω switch ON) • Video level control not adjusted properly. (Re-adjust the level control) • Nonstandard video source (such as a Camcorder or VCR) generating peak picture levels exceeding +150 IRE units. (Re-adjust the level control)
ONLINE	Green	On	Encoder enabled and transmitting valid data	None
		Off	Encoder not transmitting valid data	Major—possible causes: <ul style="list-style-type: none"> • Transmitter disabled • Encoder in a LOCK LOST condition
		Blinking	Laser diode optical output power has decreased by more than 1.25 dB below its initial value and may have failed completely	Major— affects the functionality of the encoder. Laser must be repaired.

**The source status LEDs indicate:**

- Whether the encoder is in analog or SDI mode
- When a *lost carrier detect* condition exists in SDI mode
- When AUDIO ALARM/LASER OFF switch (page 3-52) is set to LASER OFF

**Figure 3-17. Source Status LEDs**

Table 3-5 describes the four LEDs.

Table 3-5. Source Status LEDs

Name	Color	State	Indication
SDI	Green	On	The DL1220 encoder* is transmitting in SDI mode. If the TRANSMIT SOURCE SELECT switch is set to SDI and the SDI signal is lost, this LED remains on and the STANDBY LED goes on as well.
ANALOG VIDEO	Green	On	The encoder is transmitting in analog mode
STANDBY	Yellow	On	The DL1220 encoder* has lost <i>carrier detect</i> while transmitting in SDI mode. A standby signal is being sent. The SDI LED should be on as well.
LASER DISABLE	Red	On	The AUDIBLE ALARM/LASER OFF switch has been set to LASER OFF. The encoder laser is disabled; if two lasers are present, both are disabled. Setting the switch to LASER OFF generates a major alarm condition.
* The SDI and STANDBY LEDs are not functional in a DL1200 encoder.			

The relay/data LEDs indicate:

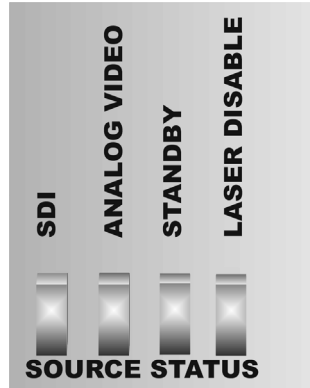
- Activity on the RELAY input connectors ([page 3-28](#))
- Activity on the RS-232 DATA INPUTS port ([page 3-26](#))

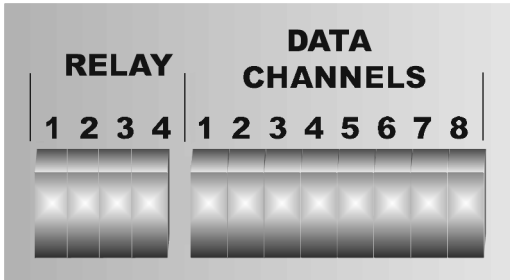

Figure 3-18. Relay/Data LEDs

Activity at the DATA INPUTS port and the RELAY connectors is significant when the encoder is in analog mode because relay and data information is multiplexed into the Artel-270 digital output signal.

Note: Relay and data inputs are not added to the output transmission when an DL1220 encoder is operating in SDI mode.

[Table 3-6](#) describes the 12 LEDs.

Table 3-6. Relay/Data LEDs

Name	Color	State	Indication
RELAY (1 ... 4)	Green	On	Encoder detects a contact closure across the corresponding user relay input line.
DATA CHANNELS (1 ... 8)	Green	On	Encoder detects a data transition on the corresponding data input line. These LEDs are not status indicators. Data rates as low as 50 bits/s keep the LEDs on.

**The output status LEDs indicate:**

- When an encoder in analog mode is transmitting the main video
- When an encoder in analog mode is transmitting the test screen to the decoder
- When the VIDEO SELECT switch (page 3-32) is set to AUTO

**Figure 3-19. Output Status LEDs**

Table 3-7 describes the four LEDs:

Table 3-7. Output Status LEDs

Name	Color	State	Indication
TEST ON	Yellow	On	Encoder is transmitting the test screen to the decoder if the transmission path is analog.
AUTO ON	Green	On	VIDEO SELECT switch is set to AUTO.
MAIN ON	Green	On	Encoder is ready to transmit the main (Artel-270) video signal.
MAIN SYNC	Green	On	Encoder detects sync pulses in the main video input signal and is transmitting a video signal.

Using the METER SELECT Switch and the AUDIO LEVEL Display

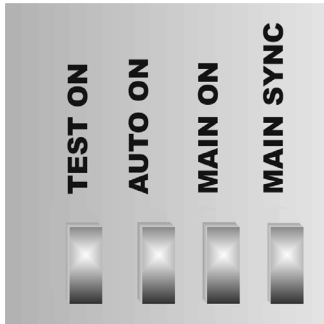
Location

The AUDIO LEVEL display and six-position METER SELECT switch are located on the encoder's front panel (items 4 and 6, respectively, on [page 3-2](#)).

Purpose

The METER SELECT switch serves two purposes:

- To select the type of status information to be shown in the AUDIO LEVEL display
- To specify an audio channel to be analyzed by an external device connected to the AUDIO MONITOR connector ([page 3-42](#))

The display is intended for use with steady-state test tones. Program audio will display rapidly changing values that may be difficult to read.

When an overload condition (at +22 dBm) is detected, the display shows a row of upward-pointing arrows. When no audio signal is detected (at -16 dBm), the display shows a row of downward-pointing arrows.

The METER SELECT switch in an AUDIO position:

Instructs the encoder to show the peak power level (in dBm) of the selected audio channel (A, B, C, or D) in the AUDIO LEVEL display. In the example below, the METER SELECT switch is set to audio channel C and the AUDIO LEVEL display shows its peak power level, -8.2 dBm.

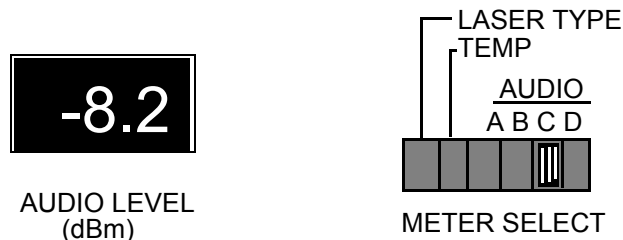

Figure 3-20. AUDIO LEVEL Display and METER SELECT Switch

If you connect an external audio analyzer to the AUDIO MONITOR connector while the METER SELECT switch is set to C, the device will be able to analyze audio channel C.



Note: Audio channel information is of interest when the encoder is operating in analog mode. Audio information cannot be added to an SDI signal by a DigiLink encoder.

The METER SELECT switch in the TEMP position:

Causes the AUDIO LEVEL display to show the internal temperature of the encoder in degrees Celsius. Valid temperatures range from 0 ... 60° C.

If a temperature greater than 60° C is sensed, the TEMP HIGH LED is illuminated and a minor alarm is recorded (see [page 3-45](#)).

The METER SELECT switch in the LASER TYPE position:

Causes the AUDIO LEVEL display to show a value or a channel number indicating the wavelength of a laser in the encoder. This information may be particularly useful if a laser cartridge is installed.

- For a unit with only a built-in laser, a wavelength value of 1310 or 1550 will be shown, depending on the encoder model
- For a unit with a laser cartridge installed, the wavelength is represented by a channel number (see [page 1-7](#) for details)
- For a unit with a high-power WL15+4 1550 nm laser, the AUDIO LEVEL display will show 155+.

If you have both a built-in laser and a laser cartridge installed in the encoder, only the channel number of the laser in the cartridge will be shown in the AUDIO LEVEL display. The wavelength of the built-in laser will not be displayed, even if it is the only laser is in use.

Note: If you are using a DL1200EN or DL1220EN encoder, which does not have a built-in laser, and no laser cartridge has been installed, placing the METER SELECT switch in the LASER TYPE position causes a value of 1310 to appear in the AUDIO LEVEL display. This is a default display.

Setting the AUDIBLE ALARM/LASER OFF Switch

Location

The three-position AUDIBLE ALARM ON/LASER OFF switch is located on the encoder's front panel (item [10](#) on [page 3-2](#)).

Purpose

The switch serves two purposes:

- To activate the encoder's internal alarm buzzer
- To disable the encoder's optical transmitter(s)

Audible alarm control

The encoder has an internal buzzer that can be configured to sound whenever the encoder detects a major alarm condition.

- When the switch is in the ON position, the audible alarm buzzer will sound when a major alarm is detected
- When the switch is in the OFF position, the audible alarm buzzer does not sound when a major alarm is detected

Laser-disable control

When the switch is in the LASER OFF position, you disable any and all lasers in the encoder, including an optional laser cartridge.

Note: We recommend that you always disable the optical transmitters before you perform routine maintenance or re-cable the encoder.

Setting the switch to LASER OFF generates a major alarm condition and illuminates the LASER DISABLE LED ([page 3-47](#)).



Wiring the ALARM Relay Connectors

Location

Two three-terminal alarm relay contact closures—one for LOCAL MAJOR alarms and one for LOCAL MINOR alarms—are located on the encoder's rear panel (item 26 on page 3-3).

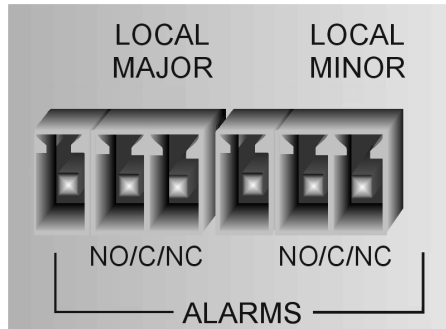

Figure 3-21. ALARM Relay Connectors

Purpose

These contact closures can be used to connect the encoder to an external coil device (such as a lamp or a horn), which can be activated when the encoder detects an alarm condition.

The ALARM relay connectors can be wired as normally closed (NC), in which case it will open when an alarm condition is sensed; or normally open (NO), in which case it will close when an alarm condition is sensed.

To connect an external coil to an alarm relay connector, use one of the three-pin removable screw wire clamp connectors shipped with the DigiLink. The connectors accept #24 ... #18 gauge twisted-pair wire.

Note: Local alarm data can be sent to the decoder when the encoder is operating in analog mode. The same information that can be displayed from the encoder as local can be displayed from the decoder as remote data (see page 4-31).

The alarm relay contact rating is 48 VAC or VDC @ 100 mA. All contact pairs are isolated from chassis ground and from each other. Maximum applied voltage from any contact to chassis ground must be less than 100 VDC. The contacts are not polarity-sensitive.

Using the Test Screen Editor

Location

Physically, the Test Screen editor comprises four buttons located on the encoder's front panel (item 5 on [page 3-2](#)):

- <PGRM>
- <UP>
- <DOWN>
- <ENTER>

These buttons give you access to a series of menus and editing capabilities within those menus. To operate the editor, connect the encoder to the appropriate NTSC or PAL monitor via the VIDEO MONITOR port.

Purpose

The encoder stores a test screen, which it can output to the VIDEO MONITOR port ([page 3-40](#)) or one of the signal output ports (see [page 3-32](#)). The Test Screen editor gives you the ability to customize your test screen.

You can generate up to five lines of displayed text and choose from a series of test pattern backgrounds. A preview of the test pattern you select and text you enter is displayed on the monitor as you generate them.

The Test Screen editor works independently of the encoding/transmission functions. The encoder continues to function while you are accessing the editor menus.



The default test screen

A default test screen is provided in the encoder. It will be displayed on the monitor if you do not customize a new test screen with the Test Screen editor.

The Color Bars test pattern is the default test screen for the following encoders:

- DL1200E and DL1200E-48
- DL1200EL and DL1200EL-48
- DL1200EN and DL1200EN-48
- DL1220E and DL1220E-48
- DL1220EL and DL1220EL-48
- DL1220EN and DL1220EN-48

The Luma Bars 3 test pattern is the default test screen for the following encoders:

- DL1200EP and DL1200EP-48
- DL1200EPL and DL1200EPL-48
- DL1200EPN and DL1200EPN-48
- DL1220EP and DL1220EP-48
- DL1220EPL and DL1220EPL-48
- DL1220EPN and DL1220EPN-48

Editor timeout

The Test Screen editor has a 5 min timeout feature. If you have initiated the editor and do not take any action for 5 minutes, it times out.

If you have selected a new test pattern or saved one or more lines of text, they will be output to the VIDEO MONITOR port after:

- You exit the editor menus
- The editor times out

The Test Screen editor buttons

Table 3-8 defines the functions of the four Test Screen editor buttons.

Table 3-8. Editor Buttons and Functions

Pushing...	Enables you to...
<PGRM> (program)	<ul style="list-style-type: none"> • Initiate the editor • Change <UP> and <DOWN> to scrolling character selection cursors in text entry mode • Activate the text entry mode
<UP>	<ul style="list-style-type: none"> • Move the arrow cursor up • Scroll the character cursor from left to right (after you push <PGRM> to change the button function)
<DOWN>	<ul style="list-style-type: none"> • Move the menu cursor down • Toggle the character cursor between the upper and lower character rows (after you push <PGRM> to change the button function)
<ENTER>	<ul style="list-style-type: none"> • Select an alphanumeric character from a character row in the Text Entry menu • Increment the line number displayed in the Line Selected option of the Text Entry menu • Select a menu option



The Test Screen editor's menu structure

Figure 3-22 is a flowchart of the encoder's Test Screen editor menus. They can be viewed on the attached monitor when you push <PRGM>.

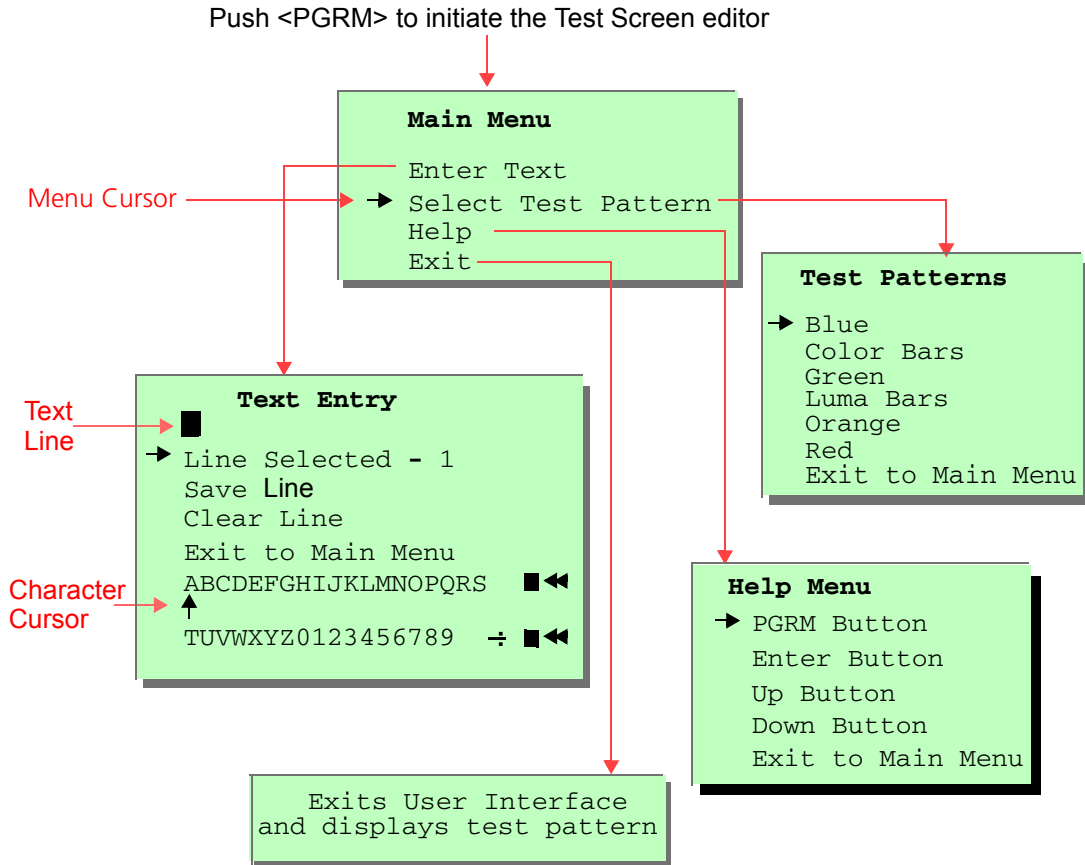

Figure 3-22. User Interface Menu Flowchart

Note: The Test Patterns menu shown above displays NTSC test patterns. Refer to [page 3-63](#) for the list of available PAL test patterns.

To operate the Test Screen editor:

1. Connect the appropriate NTSC or PAL monitor to the VIDEO MONITOR port (page 3-40).
2. Set the MONITOR SOURCE SELECT switch (page 3-41) to TEST VIDEO.
3. Push <PRGM>.

Using the Main Menu

The Main menu options enable you to perform the actions defined in Table 3-9.

Table 3-9. Main Menu Options

Moving the cursor to...	Enables you to...
Enter Text	Display the Text Entry menu.
Select Test Pattern	Display the Test Patterns menu.
Help	Display Help screens for the buttons.
Exit	Exit the editor and display the programmed test pattern and text.

To access the Main menu, press <PGRM>. The Main menu appears on the attached monitor:

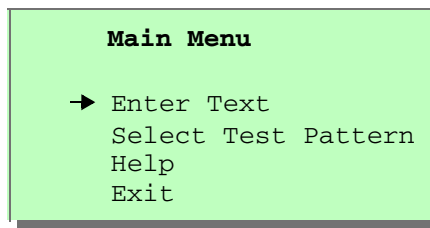

Figure 3-23. Main Menu



To select a Main menu option:

1. Position the cursor arrow next to the option you want to select. The cursor can be moved by pushing <UP> or <DOWN>.
2. Press <ENTER>.

Result: If you have selected Enter Text, Select Test Pattern, or Help, the menu associated with that option will appear on the monitor. If you have selected Exit, the programmed test pattern and any previously saved text will appear.

Entering Text

When you select Text Entry from the Main menu, the following menu appears on the monitor:

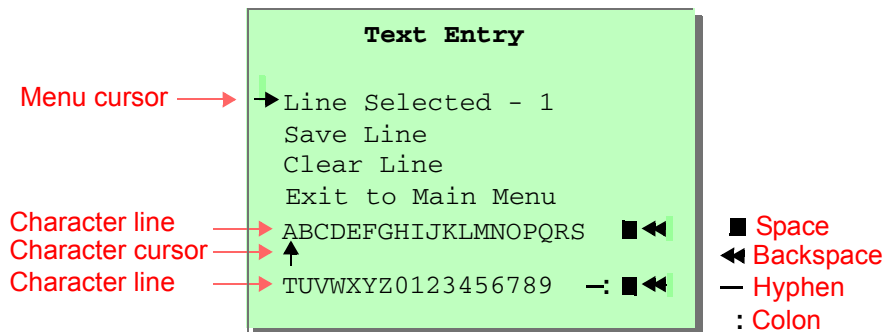

Figure 3-24. Text Entry Menu

With this menu, you can enter up to five lines of alphanumeric text, with up to 24 characters per line. The text is previewed on the monitor as you enter it. You can clear existing lines of text from the test screen and save newly entered text lines to the test screen. [Table 3-10](#) describes the Text Entry menu options.

Table 3-10. Text Entry Menu Options

Option Name	Enables you to...
Line Selected	Display the text line (1 ... 5) to create, save, or clear.
Save Line	<ul style="list-style-type: none"> • Save the text line displayed in the Text Entry menu. When you save a text line, the line displays as reverse video for approximately 3 s. • Save a cleared line from the test pattern display.
Clear Line	Clear the text line displayed in the Text Entry menu. To clear the text line permanently (that is, clear the text from the test pattern display) save the change using the Save Line option.
Exit to Main Menu	Close the menu and display the Main menu.

Using the Text Entry Cursors

The Text Entry menu contains two cursors:

- A *menu cursor*, which appears as a horizontally pointing arrow that moves <UP> or <DOWN> beside the four menu options and beside the character lines at the bottom of the menu.
- A *character cursor*, which appears as a vertically pointing arrow that moves horizontally along the two rows of alphanumeric characters at the bottom of the menu

Only one cursor is active at a time. By default, the menu cursor is always active when you first access the menu.

To activate the character cursor, position the menu cursor next to a character line and push <PGRM>. To reactivate the menu cursor, push <PGRM> again.

To select a line:

1. Use <UP> or <DOWN> to position the menu cursor beside the Line Selected option.

The currently selected line number (1 ... 5) is displayed beside this menu option. Any text currently on that line (unsaved from this session or saved from this or a previous session) is displayed at the top of the menu.



2. If you want to enter text on a line other than the currently selected line, push <ENTER> to increment the line number. <ENTER> increments from 1 ... 5, then wraps from 5 back to 1.
3. Once the desired line number has been selected, you may save the text that is currently on it, clear the text on it, or enter new text on it.

Push <Down> to position the menu cursor next to the character rows (to enter text) or the desired menu option (to save or clear text).

To enter text:

1. Select the line you want to enter text on using the procedure on [page 3-60](#).
2. Position the menu cursor next to a character line and push <PGRM>.

Result: The menu cursor disappears and the character cursor appears as a vertical arrow between the two rows of characters. Also, <UP> now functions as a horizontal scrolling mechanism for the character cursor, and <DOWN> functions as a toggle between the upper or lower rows of characters.

3. Select the first character you want to enter by pushing <UP> to scroll from left to right across the character columns.

When the character cursor arrow is pointing up, you can select characters from the top row. When it is pointing down, you can select from the bottom row.

Push <DOWN> if you need to toggle the character cursor between character rows. The character that is currently being pointed to by the character cursor is displayed to the left of the character rows.:

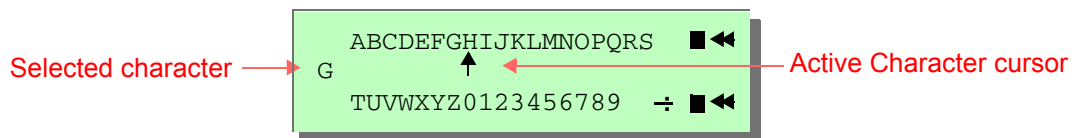

Figure 3-25. Active Text Entry Feature and Character Cursor

4. When the character cursor is pointing to the character you want, push <ENTER>.

5. Select the next character you want to enter, repeating steps 3 and 4 for each character entry.

Pushing <UP> scrolls only from left to right. If you want to select a character to the left of the currently positioned character cursor, you must scroll all the way to the right of the row and push <UP> again to wrap back to the left side of the row.

If you want to delete a character that you have entered on the selected line, move the character cursor to the backspace symbol— and push <UP>.

Result:The cursor backspaces from right to left, deleting each character that it moves back over.

6. When the text line is complete, push <PGRM> to reactivate the menu cursor. You may now either save or clear the line. If you exit the editor without saving the line, it will be cleared automatically.
7. Save the text line by selecting the Save Line option and pushing <ENTER>.

To save a text line

1. Select the line you want to save using the procedure on [page 3-60](#).

The (saved and unsaved) text on that line is displayed at the top of the Text Entry menu.

2. Position the menu cursor next to the Save Line option and push <ENTER>.

While being saved, the line is displayed in reverse video for approximately 5 s.

To save a line or save a cleared line, place the cursor next to the Save Line option and push <ENTER>. When you save a text line, the line displays as reverse video for approximately 3 s.

To clear a text line:

1. Select the line you want to save using the procedure on [page 3-60](#).

The (saved and unsaved) text on that line is displayed at the top of the Text Entry menu.



2. Position the menu cursor beside the Clear Line option and push <ENTER>.
Result: The unsaved text is deleted. Previously saved text is cleared from the Text Entry menu but remains in the test screen display.
3. To permanently clear the previously saved text line from the test screen display, position the menu cursor beside the Save Line option and push <ENTER>
Result: The text line is overwritten by the empty line in the Text Entry menu.

Programming a Test Pattern

When you select Test Patterns from the Main menu one of the following two menu screens will appear on the monitor. The Test Pattern menus differ on different versions of the encoder.

If you are using any DigiLink encoder except the DL1220EP or DL1220EP-48, the following NTSC Test Pattern menu will appear on the monitor:

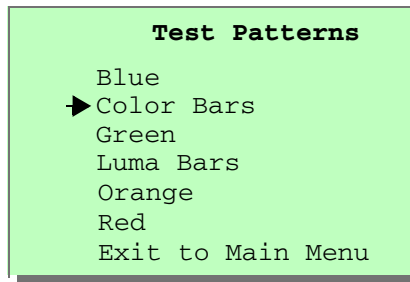

Figure 3-26. NTSC Test Patterns Menu

If you do not select an alternate test pattern, the Color Bars test pattern appears on your test screen by default.

If you are using a DigiLink DL1220EP or DL1220EP-48 encoder, the following PAL Test Pattern menu will appear on your monitor:

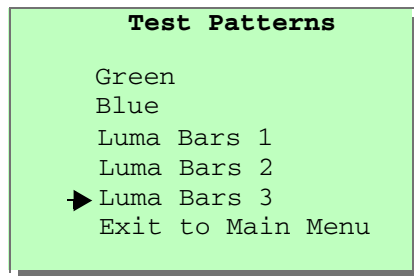

Figure 3-27. PAL Test Patterns Menu

If you do not select an alternate test pattern, the Luma Bars 3 test pattern appears on your test screen by default.

To select a test pattern:

1. Use <UP> or <DOWN> to position the menu cursor beside the desired test pattern.
2. Push <ENTER>.

Result: The selected test pattern appears on the monitor display immediately and is saved automatically.



Getting Help

When you select Help from the Main menu, the following menu screen appears on the monitor:

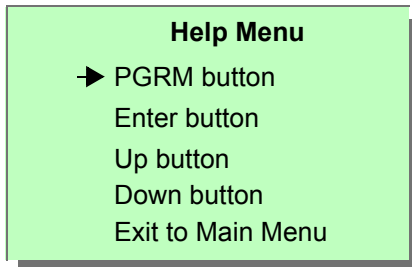

Figure 3-28. Editor Buttons Help Menu

From this menu, you can go to help text describing the Test Screen editor buttons.

Displaying a Help Menu

To display a Help menu for a User Interface button:

1. Use <UP> or <DOWN> to position the menu cursor beside the button you want Help on.
2. Push <ENTER>.

Result:: A Help screen appears. [Figure 3-29](#) ... [Figure 3-32](#) illustrate the associated Help screens.

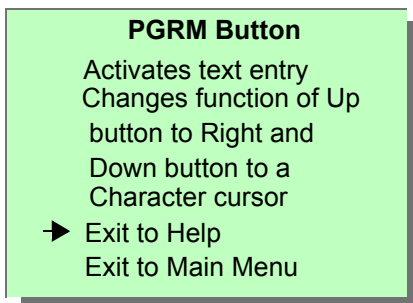

Figure 3-29. <PGRM> Help Screen

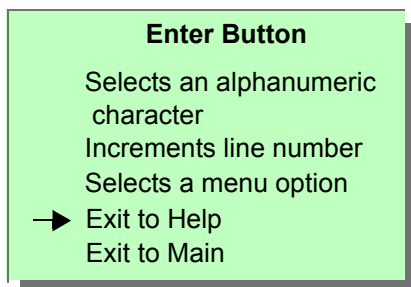

Figure 3-30. <ENTER> Help Screen

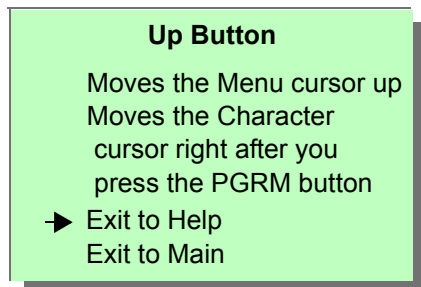

Figure 3-31. <UP> Help Screen

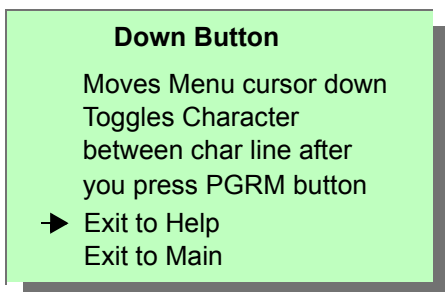

Figure 3-32. <DOWN> Help Screen

3. To go back to the Help Menu screen, move the menu cursor beside Exit to Help and push <ENTER>. To go back to the Main Menu screen, move the menu cursor beside Exit to Main and push <ENTER>.



Where to Go Next

[Chapter 4](#) describes DL1200/DL1220 decoders.



4

Configuring and Cabling the Decoder

This chapter describes how to configure the decoder using the panel switches and cable ports. The major topics are:

- [Decoder Front and Rear Panel Views \(page 4-2\)](#)
- [Identifying the Unit \(page 4-4\)](#)
- [Applying Power \(page 4-5\)](#)
- [Establishing Decoder Inputs \(page 4-9\)](#)
- [Establishing Decoder Outputs \(page 4-16\)](#)
- [Using Internal and External Display Capabilities \(page 4-35\)](#)
- [Using the Test Screen Editor \(page 4-47\)](#)

Decoder Front and Rear Panel Views

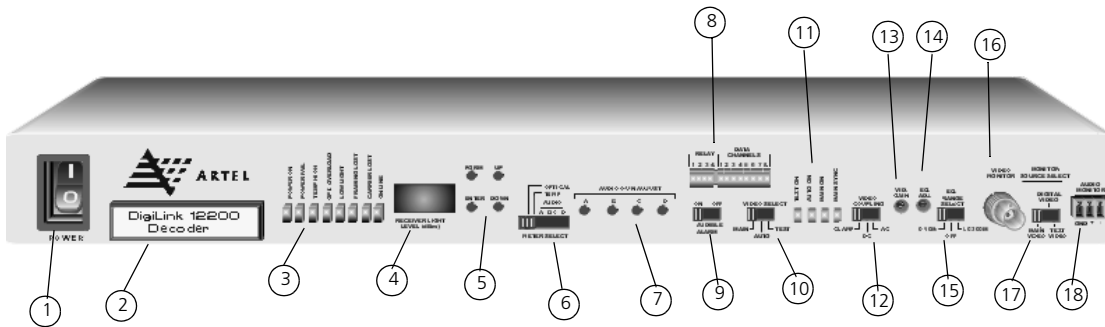

Figure 4-1. DigiLink Decoder Front Panel

Table 4-1. Decoder Front Panel Elements

Item	Panel Element	for details, see...
1	POWER switch	page 4-7
2	Decoder label	page 4-4
3	Device status LEDs	page 4-36
4	RECEIVER LIGHT LEVEL window	page 4-40
5	Test Screen editor buttons	page 4-47
6	METER SELECT switch	page 4-40
7	AUDIO GAIN ADJUST potentiometers	page 4-27
8	Relay/Data LEDs	page 4-38
9	AUDIBLE ALARM switch	page 4-44
10	VIDEO SELECT switch	page 4-17
11	Output status LEDs	page 4-39
12	VIDEO COUPLING switch	page 4-24
13	VIDEO GAIN potentiometer	page 4-22
14	EQUALIZATION ADJUSTMENT potentiometer	page 4-22
15	EQUALIZATION RANGE SELECT switch	page 4-21
16	VIDEO MONITOR port	page 4-44
17	MONITOR SOURCE SELECT switch	page 4-45
18	AUDIO MONITOR port	page 4-46

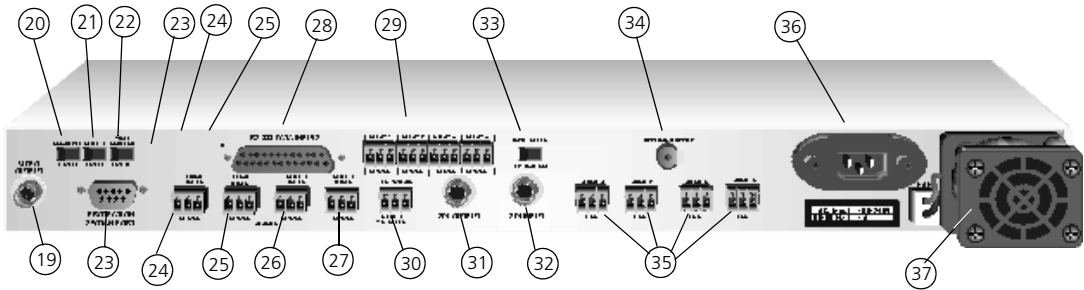

Figure 4-2. DigiLink Decoder Rear Panel

Table 4-2. Decoder Rear Panel Elements

Item	Panel Element	for details, see...
19	VIDEO OUTPUT port	page 4-20
20	SCRAMBLE switch	page 4-33
21	EMS CONTROL switch (not used)	
22	VIDEO SQUELCH switch	page 4-19
23	PROTECTION SWITCH port	page 4-34
24	LOCAL MAJOR ALARM connector	page 4-31
25	LOCAL MINOR ALARM connector	page 4-31
26	REMOTE MAJOR ALARM connector	page 4-31
27	REMOTE MINOR ALARM connector	page 4-31
28	RS-232 DATA OUTPUTS port	page 4-29
29	RELAY contact connectors	page 4-30
30	REMOTE VIDEO SELECT switch	page 4-18
31	SDI OUTPUT port	page 4-33
32	SDI INPUT port	page 4-15
33	INPUT SELECT switch	page 4-10
34	OPTICAL INPUT port	page 4-14
35	AUDIO OUTPUT connectors	page 4-26
36	AC power connector	page 4-5
37	External fan	page 4-7

Identifying the Unit

A label appears in the bezel on the left side of the decoder's front panel, below the Artel logo (see item 2 on [Figure 4-1](#)).

This label provides the unit's model number and identifies the unit as either an encoder or a decoder.

[Figure 4-3](#) shows a sample label identifying the unit as a DL1220D decoder (a decoder equipped with an AC power supply and an NTSC test signal generator.)



Figure 4-3. A Decoder Label

See [Table 1-3](#) and [Table 1-5](#) for a complete list of DL1200 and DL1220 decoder models.



Applying Power

All DigiLink decoders are available with either an AC or DC power supply. Before you install the AC or DC power cord, see [Appendix A](#) for a complete understanding of the system's electrical and environmental specifications.

Connecting an AC Power Cord

The AC connector is located on the decoder's rear panel (item [36](#) on [page 4-3](#)).

It requires a three-prong IEC 320-C13 115/230 VAC power cord.

To connect an AC power cord to a power source:

1. Make sure that the POWER switch is in the 0 (OFF) position.
2. Lift the cable strain relief and position it above the AC connector.
3. Plug the AC power cord into the power receptacle at the rear of the unit.
4. Lower the cable strain relief to lock in the AC power cord.
5. Plug the power cord into a three-wire grounding receptacle.

Connecting a DC Power Cord

The DC versions of the DigiLink decoders have a -48 VDC input connector terminal block.

Caution

When connecting a DC power supply, make sure that you are connecting the DigiLink to a -48 VDC (-38.4 ... -57.6 VDC) source that is isolated from any AC power and is reliably grounded to earth.

To connect a DC-powered decoder to a power source:

1. Locate the terminal block assembly (1) on the rear of the unit and remove the clip-on protective cover (2) as shown in Figure 4-4.

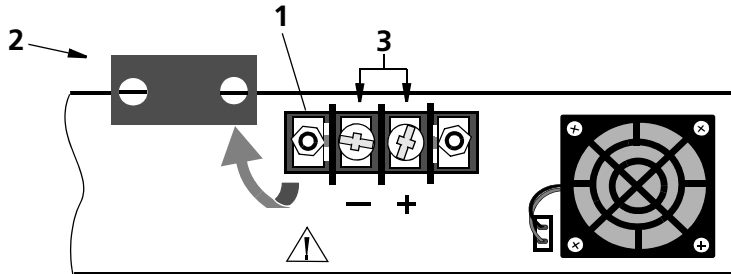

Figure 4-4. DC Power Supply Terminal Block

2. Loosen the two terminal post screws (3) marked - and +.
3. Install the DC power source cables and tighten the screws to secure the connectors to the terminal block. Ensure the spade connector terminations are positioned under the screwheads.

Warning



Before installing the spade connectors, ensure the polarity of the DC connections is correct. Reversed polarity can cause the DC input fuse to blow and may cause damage to the power supply.

4. Reinstall the protective cover (2) onto the DC terminal block.
5. Connect the other end of the power cable into an approved safety extra low voltage (SELV) energy output source.

Note: Each Digilink decoder consumes approximately 50 W from a nominal 48 VDC circuit. Slow blow (time delay) fusing, such as a T3.15 fuse with a minimum fuse capacity of 2.5 A per decoder, is recommended. If fast blow (fast-acting) fuses are used, a minimum fuse capacity of 10 A per decoder is recommended to prevent nuisance blows.



Powering up the Decoder

Once external power has been connected to the decoder, it can be powered up using the two-position POWER switch on the front panel (item 1 on [page 4-2](#)).



Figure 4-5. Decoder POWER Switch

Toggle the POWER switch to the **1** (ON) position. As the decoder powers up, it initializes and turns on the LEDs briefly.

Once the decoder initializes, you can use the switches on the front and rear panels to configure it and the LEDs to monitor its status.

Cooling the unit (external fan)

The decoder has an external fan on its rear panel (item 37 on [page 4-3](#)) that remains *on* while the unit is under power.

Replacing the external fan

Replacing the external cooling fan requires a DL1K-FAN-ED replacement fan, which is available from your Artel customer service representative, and a Phillips screwdriver. This task should be performed by a qualified service person.

Note: The fan replacement procedure can be performed while the decoder is under power.

1. Remove the fan wire connector (1) from its receptacle on the rear of the unit. The connector is a pinch clip that needs to be pushed down for removal.

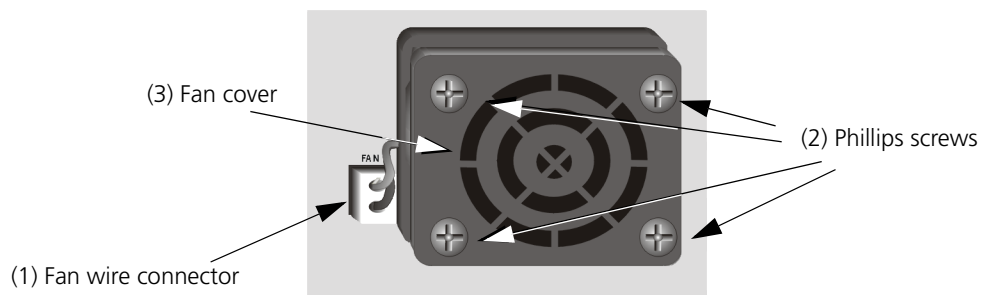

Figure 4-6. Locating the Fan Wire Connector

2. With the Phillips screwdriver, remove the four screws (2) that secure the fan to the unit. Set the screws aside for later use.
3. Remove the fan cover (3) and set it aside for use later.
4. Remove the fan.
5. Align the new DL1K-FAN-ED fan unit with the four screw holes in the chassis.
6. Replace the fan cover and reinsert the four Phillips screws.
7. Plug the new fan wire connector into the receptacle.



Establishing Decoder Inputs

Overview

Input transmission media

The decoder can receive a digital input signal optically via its OPTICAL INPUT port ([page 4-14](#)) or electrically via its SDI INPUT port ([page 4-15](#)).

The one exception is the DL1200DN decoder, which does not have an optical receiver or an OPTICAL INPUT port. The DL1200DN can accept only Artel-270 input signals that are transmitted electrically.

Use the INPUT SELECT switch ([page 4-10](#)) to specify the port from which the decoder will take its input signals.

Input signals

Two types of digital input signals can be received by a DigiLink decoder:

- An Artel-270 signal
- A standard 270 Mbit/s serial digital interface (SDI) signal formatted per SMPTE 259M-c 4:2:2/CCIR601

An Artel-270 signal can be produced by any DigiLink encoder operating in analog mode. Any DigiLink decoder can decode an Artel-270 input.

An SDI input signal is produced by a DL1220 encoder operating in SDI mode. Only the DL1220 decoders can accept SDI input signals. The DL1200 decoders do not support SDI input signals.

For a description of analog and SDI operating modes, see [page 1-3](#).

A special software switch ([page 4-11](#)) in the Main menu of the Test Screen editor allows you to specify whether the input signal is Artel-270 or SDI. The decoder uses this switch setting to make decisions about how to handle the input in the decoding process.

If the decoder is receiving an SDI-formatted input signal, you need to set the decoder's SCRAMBLE switch ([page 4-33](#)) to the same setting as the SCRAMBLE switch on the encoder ([page 3-29](#)). The decoder's SCRAMBLE switch enables or disables a descrambler for an SDI input signal.

Setting the INPUT SELECT Switch

Location

The two-position INPUT SELECT switch is located on the decoder's rear panel (item 33 on [page 4-3](#)).

Model restrictions

The DL1200DN decoders support only electrical inputs. If the switch is set to the OPTICAL position, the decoder ignores the setting and looks for inputs on the SDI (electrical) INPUT port.

Purpose

Use this switch to specify whether the input signal to be processed by the decoder is coming in over the electrical port or the optical port.

- To use the signal being received on the OPTICAL INPUT port ([page 4-14](#)), set the INPUT SELECT switch to the OPTICAL position
- To use the electrical signal being received on the SDI INPUT port ([page 4-15](#)), set the INPUT SELECT switch to the SDI position

When the INPUT SELECT switch in the OPTICAL position:

For all decoders except the DL1200DN, the decoder will ignore activity on the SDI INPUT port and will process input only when they are received on the OPTICAL INPUT port. The decoder will be idle whenever there is no activity on (or no fiber optic cable connected to) the OPTICAL INPUT port.

When the INPUT SELECT switch in the SDI position:

The decoder will ignore activity on the OPTICAL INPUT port and process inputs only when they are received on the SDI INPUT port. The decoder will be idle whenever there is no activity on (or no coaxial cable connected to) the SDI INPUT port.

Note: If you are using a DL1200D, DL1220D, or DL1220DP decoder (all of which do have a functional OPTICAL INPUT port), the LOW LIGHT LED will illuminate constantly when the INPUT SELECT switch is set to SDI. Ignore this LED indication in this circumstance.



Setting the Change Mode Switch

Location

The Change Mode software switch is a Main menu option in the Test Screen editor (see [page 4-47](#)). It allows you to select one of two or three operating modes available on the decoder.

Mode and model restrictions

The switch should always be set to ANA on a DL1200 decoder. It should be set to ANA on a DL1220 decoder whenever it is receiving an Artel-270 signal from a DigiLink encoder as its input.

SDI is a valid setting when the decoder is receiving an SDI input signal, whether it is in SMPTE 259M format or another 270 Mb/s format such as DVB-ASI. Setting the switch to SDI disables frame checking of the serial bit stream, which is not needed when a decoder is passing an SDI digital signal.

If the decoder is receiving a non-SMPTE 270 Mb/s SDI input (e.g., DVB-ASI), the operating mode should always be set to SDI. If the decoder is receiving an SMPTE-formatted 270 Mb/s SDI input, the EDH operating mode should be selected—EDH mode enables the decoder to monitor the error detection handling capability that can be carried in an SMPTE 259M-C signal.

Caution

If the decoder is set to EDH mode and is receiving an Artel-270 input, the decoder will still be able to output analog video but it will not be able to detect or report FRAMING LOST alarm conditions, even if real framing errors are present in the input signal.

If the decoder is set to EDH mode and is receiving an Artel-270 input, the decoder will still be able to output analog video but problems will occur in the electrical output from the decoder.

If the decoder is set to EDH mode and is receiving an inappropriate SDI signal type such as DVB-ASI, the encoder-decoder link will fail.

Purpose

This Change Mode software switch can be toggled to analog (ANA), serial digital interface (SDI), or error detection handling (EDH) mode. The choices refer to the type of input signal being received by a DL1220 decoder.

You can set Change Mode to:

- ANA when the decoder is receiving an Artel-270 input signal
- SDI if the decoder is a DL1220 and is receiving any 270 Mb/s SDI input signal
- EDH only when the decoder is a DL1220 and is receiving a 270 Mb/s SDI signal specifically in the SMPTE 259M-C 4:2:2 format

Note: SDI is also a valid setting for the SMPTE 259M case. However, the error detection handling capabilities available in SMPTE 259M can be accessed only if the decoder is set to EDH mode.

If the Change Mode switch is set to ANA and the decoder receives an SDI input signal, two things happen:

- A major alarm condition is triggered
- The FRAMING LOST LED illuminates

Toggling the switch to either the SDI or EDH setting masks out framing in the input signal. Thus the major alarm condition is disabled and the FRAMING LOST LED turns off.

Use the push-button on the decoder front panel (item 5 on [page 4-2](#)) and the RECEIVER LIGHT LEVEL window (item 4 on [page 4-2](#)) to toggle the software switch.

To toggle the Change Mode setting:

1. Press <PGRM> once.

Result: The RECEIVER LIGHT LEVEL display shows the current setting (ANA, SDI, or EDH) for approximately 1.5 seconds.

Note: If <PRGM> was pushed before you started the procedure or if you push it more than twice in step 1, the program function goes into an *unknown* mode and this switch toggling procedure will not work. If the Change Mode switch setting does not appear in the RECEIVER LIGHT LEVEL display, you have two choices:



- Connect a video monitor to the decoder and set the MONITOR SOURCE SELECT switch to TEST VIDEO (page 4-45). With the monitor, you can see which mode has been selected and exit from the menus appropriately. Figure 4-7 shows what the Main Menu test screen looks like in the various modes.

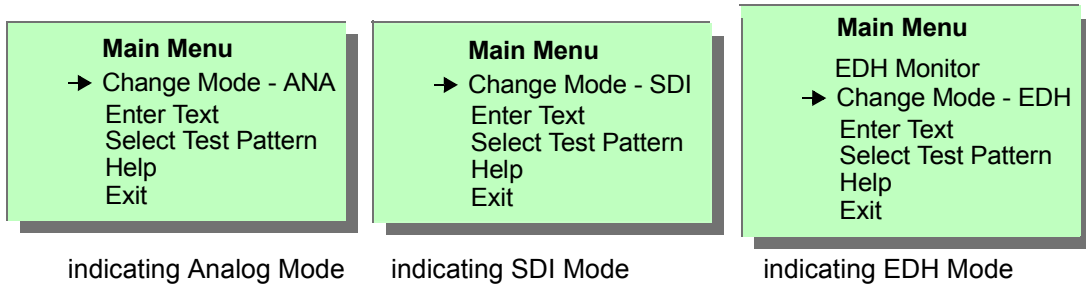

Figure 4-7. Main Menu Mode Indications

If the decoder is in ANA or SDI mode, the Main Menu test screen looks similar. If the decoder is in EDH mode, the Main Menu screen has an additional entry—EDH Monitor—in the top menu position.

For more information on monitoring the test screens, see page 4-47.

- In the event that a video monitor is not available, you can cycle power on the decoder to reset the program to a known condition. At this point, the switch toggling procedure will work as described here.

2. Push <Enter>.

Result: The switch setting toggles (from ANA to SDI or from SDI to ANA). The RECEIVER LIGHT LEVEL display shows the new setting for approximately 1.5 seconds.

3. Push <PGRM> again.

Result: The new switch setting is saved and shown in the RECEIVER LIGHT LEVEL display for another 1.5 seconds.

Decoder Input Ports

Cabling the OPTICAL INPUT Port

Location

The OPTICAL INPUT port is an FC-PC female optical connector on the decoder's rear panel (item 34 on [page 4-3](#)).

Model and input signal restrictions

All DigiLink decoders except the DL1200DN models support an OPTICAL INPUT port. The DL1200DN decoders must receive their input signals electrically via the SDI INPUT port ([page 4-15](#)).

Purpose

The decoder uses its OPTICAL INPUT port to receive an Artel 270 or SDI-formatted digital input signal via a fiber optic input cable. It is designed to operate with 9 μm single-mode optical fiber cable. You can use 50 or 62.5 μm multimode fiber for short-distance applications (less than 4 km).

To connect a fiber optic cable to the OPTICAL INPUT port:

1. Remove the protective plastic cap from the connector.

Caution

When the OPTICAL OUTPUT port is not connected to a fiber cable, cover the connector with the protective plastic cap. The cap prevents degradation of optical performance that dirt and moisture can cause.

2. Use a fiber optic cable with a male FC-PC connector on it. Insert the cable connector into the OPTICAL INPUT connector and turn it until the keys mate.

Note: FC-PC connectors are keyed and can only be mated at one radial orientation.

3. Push in the connector and tighten it.

Note: Use care when moving or installing a decoder that has a fiber cable attached to the connector. To avoid sharp bends, kinks, or twists in the optical cables, remove the cable before moving a decoder.



4. Make sure that the INPUT SELECT switch ([page 4-10](#)) is set to OPTICAL when you use the OPTICAL INPUT port.

Cabling the SDI INPUT Port

Location

The SDI INPUT port is a BNC connector on the decoder's rear panel (item [32](#) on [page 4-3](#)).

Purpose

The decoder uses this port to receive an Artel 270 or SDI-formatted digital input signal via a coaxial input cable.

The decoder can receive input from an Artel encoder or from a routing switch (see the example on [page 5-3](#)). The device providing the input signal must be within 250 m (800 ft) of the decoder.

Make sure that the INPUT SELECT switch ([page 4-10](#)) is set to SDI when you use the SDI INPUT port.

Establishing Decoder Outputs

Overview

From an Artel-270 input signal

When the decoder is receiving Artel-270 inputs from an encoder, it demultiplexes the embedded data and analog signals from the input and produces separate output channels for all the extracted information. The outputs can include:

- One analog video signal (as defined in ANSI TI.502-1988), which is output from the decoder via its VIDEO OUTPUT port ([page 4-20](#))
- Up to four channels of audio, which are output from the decoder via its AUDIO OUTPUT connectors ([page 4-26](#))
- Up to eight channels of asynchronous data, which are output from the decoder via its RS-232 DATA OUTPUTS port ([page 4-29](#))
- Up to four data states, which are output from the decoder via its RELAY OUTPUT contacts ([page 4-30](#))
- Major and minor alarm status of the encoder sending the Artel-270 signal, which is output by the decoder to its REMOTE MAJOR and REMOTE MINOR ALARM connectors ([page 4-31](#))
- If a coaxial cable is connected to the decoder's SDI OUTPUT port, the decoder will transmit the digital video signal from the Artel-270 input signal electrically via the SDI OUTPUT port

From an SDI input signal

When the decoder receives an SDI-formatted input signal from an encoder, it acts as an electrical transceiver, amplifying the signal and retransmitting it as an SDI signal via its SDI OUTPUT port.



Analog Video Output

Setting the VIDEO SELECT Switch

Location

The three-position VIDEO SELECT switch is located on the decoder's front panel (item 10 on [page 4-2](#)).

Input signal restrictions

This switch is used by the decoder only when it has received an Artel-270 input signal from a DigiLink encoder. A DL1220 decoder operating on an SDI-formatted input signal does not provide outputs to the VIDEO OUTPUT port.

Purpose

Use this switch to specify the type of signal that the decoder will send to the VIDEO OUTPUT port ([page 4-20](#)). The choices are main video (the analog video signal that the decoder has extracted from its Artel-270 input signal) or the decoder's test screen. The switch has three settings:

- MAIN—Selects the main video signal to be output to the VIDEO OUTPUT port
- AUTO—Defaults to main video whenever it is available, but switches automatically to the test screen if the main video input signal is lost (if the decoder cannot detect video sync pulses in the video signal it is trying to decode)
- TEST—Selects the test screen to be output to the VIDEO OUTPUT port

For more information on how to customize the decoder's test screen, refer to [page 4-47](#).

When the VIDEO SELECT switch is in the AUTO position, it can also be used in conjunction with the REMOTE VIDEO SELECT switch ([page 4-18](#)) to establish a remote switching station for selecting the signal type.

Cabling the REMOTE VIDEO SELECT Connector

Location

The three-terminal REMOTE VIDEO SELECT connector is located on the decoder's rear panel (item 30 on [page 4-3](#)).

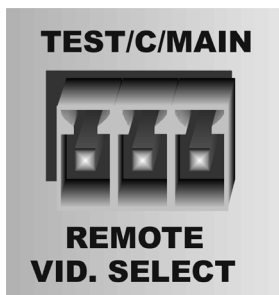

Figure 4-8. REMOTE VIDEO SELECT Connector

Input signal restrictions

This connector may be used by the decoder only when it has received an Artel-270 input signal from a DigiLink encoder. A DL1220 decoder operating on an SDI-formatted input signal does not provide outputs to the VIDEO OUTPUT port.

Purpose

When the VIDEO SELECT switch ([page 4-17](#)) is set to AUTO, this connector enables you to set up in hardware a remote switching station where you can specify the type of analog signal that will be sent to the decoder's VIDEO OUTPUT port ([page 4-20](#)). You can specify the main video signal (extracted from the Artel-270 input signal) or the test screen as the decoder's output.

To remotely select an output signal for the VIDEO OUTPUT port:

1. Set the VIDEO SELECT switch to AUTO.
If it is set to MAIN or TEST, the REMOTE VIDEO SELECT connector does not function.
2. Wire the three terminals on the REMOTE VIDEO SELECT connector to an external device such as a single-pole double-throw (SPDT) switch or a relay. Use one of the three-pin removable screw wire clamp connectors shipped with the DigiLink. The connector accepts #24 ... #18 gauge twisted-pair wire.



Once the remote video select station has been set up, use the SPDT switch or relay at the remote station to control the signal type as follows:

- When you make a contact closure between C (common) and MAIN at your remote switching location, the decoder will transmit the analog video signal it has extracted from the Artel-270 input signal
- When you make a contact closure between C and TEST at your remote switching location, the decoder will transmit the decoder's test screen

Setting the VIDEO SQUELCH Switch

Location

The two-position VIDEO SQUELCH switch is located on the decoder's rear panel (item 22 on [page 4-3](#)).

Input signal restrictions

This switch may be used by the decoder when it is extracting analog video from an Artel-270 input signal. A DL1220 decoder operating on an SDI-formatted input signal does *not* use this switch.

Purpose

If the decoder experiences a LOCK LOST or LOW LIGHT condition, the analog video signal from the embedded in the Artel-270 input signal will be lost or corrupted.

- When you turn VIDEO SQUELCH ON, the decoder prevents an invalid video signal or noise from being output from its VIDEO OUTPUT port. VIDEO SQUELCH ON also prevents the decoder from transmitting a test screen.
- When you turn VIDEO SQUELCH OFF, the decoder attempts to output the analog video via its VIDEO OUTPUT port, even if the signal is invalid or noise.

Cabling the VIDEO OUTPUT Port

Location

The VIDEO OUTPUT port is a BNC connector located on the decoder's rear panel (item 19 on [page 4-3](#)).

Input signal restrictions

This port is used to transmit the analog output signal extracted by the decoder from an Artel-270 input signal or when the MONITOR SOURCE SELECT switch ([page 4-45](#)) is set to TEST. It does not transmit digital (SDI) output signals.

Purpose

A DigiLink decoder can output standard baseband analog video signals in the form of a test screen or the decoded video extracted from an Artel-270 input signal (as defined in the ANSI TI.502-1988 standard).

Note: Ensure that the VIDEO COUPLING switch ([page 4-24](#)) is set appropriately for the analog video inputs.

For best performance and repeatability, follow these guidelines:

- Use high quality coaxial cable (for example, BELDEN type 8281 or equivalent)
- Ensure that external terminators have a 1% or better tolerance

For short cable lengths (< 10 m), you may use other cable types and impedances with little impact on performance.

To cable the VIDEO OUTPUT connector to output the video signal:

1. Connect the BNC connector on your coaxial cable to the decoder's VIDEO OUTPUT port.
2. Terminate the signal at its destination with a 75 Ω terminator.



Setting the EQUALIZATION RANGE SELECT Switch

Location

The three-position EQUALIZATION RANGE SELECT switch is located on the decoder's front panel (item 15 on [page 4-2](#)).

Input signal restrictions

This switch affects the analog output signal that the decoder has extracted from an Artel-270 input signal and is transmitting via its VIDEO OUTPUT port ([page 4-20](#)).

Be aware of this switch setting whenever there is a coaxial cable connected to the VIDEO OUTPUT port. A DL1220 decoder transmitting an SDI-formatted output signal does not use this switch.

Purpose

Use the EQUALIZATION RANGE SELECT switch to specify an appropriate cable equalization parameter for the coaxial cable that transmits the analog output signal from the decoder. Choose a cable equalization setting based on the length of the coaxial input cable:

- Set the switch in the 0-50M position when the length of your coaxial cable is ≤ 50 m (≤ 160 ft)
- Set the switch in the OFF position when no cable equalization is required—e.g., when the cable is being equalized elsewhere in the system outside the decoder
- Set the switch in the 50-300M position when the length of your coaxial cable is > 50 m (> 160 ft)

If your selection is either 0-50M or 50-300M, use the EQUALIZATION ADJUSTMENT potentiometer ([page 4-22](#)) to control the amount of cable equalization.

Adjusting the VIDEO GAIN and Cable EQUALIZATION ADJUSTMENT Potentiometers

Location

VIDEO GAIN and EQUALIZATION ADJUSTMENT potentiometers are located on the decoder's front panel (items [13](#) and [14](#), respectively, on [page 4-2](#)).

Input signal restrictions

The settings of these potentiometers affect the analog output signal extracted by the decoder from an Artel-270 input signal. They do not affect digital (SDI) output signals.

Purpose

- The VIDEO GAIN potentiometer enables you to adjust the output level of an analog video signal by ± 3 dB for 100 IRE. This is the signal being transmitted via the decoder's VIDEO OUTPUT port ([page 4-20](#)).
- The EQUALIZATION ADJUSTMENT potentiometer equalizes the signal as it is seen at the destination of the video output cable. The cable can be up to 300 m long. It should be 75 Ω Belden 8281 cable or equivalent.

The EQUALIZATION ADJUSTMENT potentiometer is used in conjunction with the EQUALIZATION RANGE SELECT switch ([page 4-21](#)) when that switch is set to either 0-50M or 50-300M. When this switch is OFF, the potentiometer does not function.

**To make video gain and cable equalization adjustments:**

1. Connect a coaxial cable to the VIDEO OUTPUT BNC connector (according to the procedure on [page 4-20](#)).
2. Make sure the cable is terminated at its destination with 75 Ω .
3. Connect a calibrated video waveform monitor or vector scope (terminated with 75 Ω) to the VIDEO MONITOR port ([page 4-44](#)).
4. Set the MONITOR SOURCE SELECT switch to MAIN VIDEO ([page 4-45](#)).
5. Set the VIDEO SELECT switch to MAIN ([page 4-17](#)).
6. Connect a test pattern generator with a multi-burst test pattern to the source end of the video cable. [Figure 4-9](#) illustrates a multi-burst video test pattern.

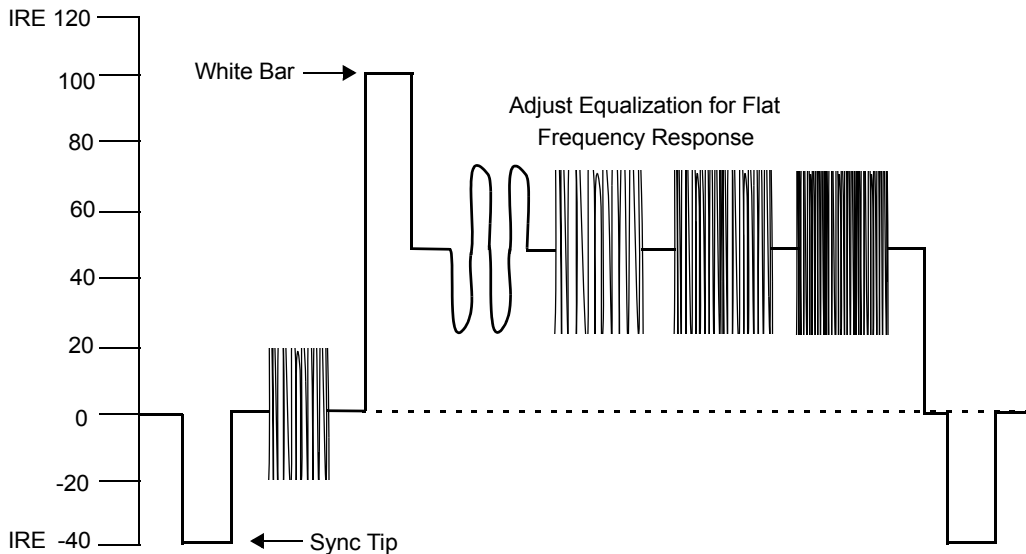
**Figure 4-9. Multi-Burst Video Test Pattern**

7. Set the cable equalization appropriately:
 - If cable equalization is not required at the device level, set the front panel EQUALIZATION RANGE SELECT switch to OFF.
 - If the cable is 50 m or less, set the front panel EQUALIZATION RANGE SELECT switch to 0-50M, then turn the EQUALIZATION ADJUSTMENT potentiometer until the signal attains a flat frequency response—i.e., until all the frequency bursts are of the same amplitude.
 - If the cable is longer than 50 m, set the EQUALIZATION RANGE SELECT switch to 50-300M, then turn the EQUALIZATION ADJUSTMENT potentiometer until the signal attains a flat frequency response—i.e., until all the frequency bursts are of the same amplitude.

To decrease the amount of cable equalization, turn the EQUALIZATION ADJUSTMENT potentiometer counterclockwise. To increase the amount of cable equalization, turn the EQUALIZATION ADJUSTMENT potentiometer clockwise.

8. Adjust the VIDEO GAIN potentiometer for 1 V peak-to-peak from sync tip to white bar (measured at the VIDEO MONITOR port).

To increase the signal level, turn the VIDEO GAIN potentiometer clockwise. To decrease the signal level, turn the VIDEO GAIN potentiometer counterclockwise.

Setting the VIDEO COUPLING Switch

Location

The three-position VIDEO COUPLING switch is located on the decoder's front panel (item 12 on [page 4-2](#)).

Input signal restrictions

This switch is applied only to analog video output signals that the decoder has extracted from the Artel-270 input. This switch settings are not used when a DL1220 decoder is transmitting SDI-formatted output signals.

Purpose

Use this switch to apply AC coupling, DC coupling, or clamping to the analog video output signal that the decoder is sending to the VIDEO OUTPUT port ([page 4-20](#)). The setting needs to be based on the type of video input that was encoded into the Artel-270 signal by the encoder that sent the input signal to the decoder.



Note: When the decoder is receiving an Artel-270 input signal, its VIDEO COUPLING switch should have the same setting as the encoder that produced the input signal.

The analog input should be AC-coupled for:

Telephony or clock signals that do not contain a long-term DC component (for example, T1, DS1, DS1C, E1, T2, and E2).

The analog input should be clamped for:

Normal (NTSC or PAL) video signals that contain a standard -40 IRE sync pulse. The clamp circuit corrects for ± 1 V of differential offset in the incoming signal at nominal gain settings.

The analog input should be DC-coupled for:

Video signals that do not contain a standard -40 IRE sync pulse—e.g., radar signals and certain scrambled signals. I

Caution

Do not DC-couple a normal (NTSC or PAL) video signal. DC coupling a normal signal can cause an overload condition.

Set the switch to the CLAMP position whenever the decoder is receiving a normal video signal.

Audio Outputs

Cabling the AUDIO OUTPUT Connectors

Location

Four three-terminal AUDIO OUTPUT connectors (AUDIO A, B, C, and D) are located on the decoder's rear panel (item 35 on [page 4-3](#)).

Input signal restrictions

These connectors are used only when the decoder is transmitting audio that it has extracted from an Artel-270 input signal. A DL1220 decoder operating on an SDI-formatted input signal does not provide outputs to these connectors.

Purpose

Audio data are extracted by the decoder from an Artel-270 input signal and are output from the decoder via these connectors. Each AUDIO OUTPUT connector provides a balanced two-wire plus shield connection.

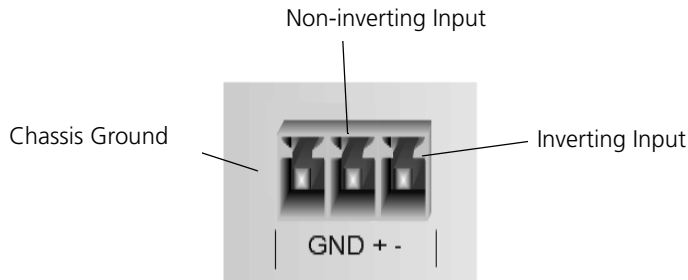

Figure 4-10. An AUDIO OUTPUT Connector

To set your decoder up to transmit audio outputs

1. Use #24 ... #18 gauge twisted-pair wire to transmit the audio output signals from the AUDIO OUTPUT connectors.

Note: For best performance, we recommend shielded twisted-pair cable. If you use multi-pair cable, make sure that each pair is shielded separately to maintain signal quality and minimize noise and crosstalk.

2. To eliminate ground loops, ground the shields at one end of the cable only. We recommend grounding the shields at the driven (source) end of the cable.



3. Make sure the wires are properly terminated (with 600 Ω) at the receiving end of the link.

Note: The audio channels on the DigiLink products are pre-adjusted to deliver unity gain between the audio input to the encoder and the audio output from the decoder. However, in the event that the audio output levels need adjustment, a set of AUDIO GAIN ADJUST potentiometers is provided on the decoder.

Adjusting the Audio Gain

Location

Four AUDIO GAIN ADJUST potentiometers are located on the decoder's front panel (item 7 on [page 4-2](#)).

Input signal restrictions

These potentiometers are used to adjust audio channels that are outputting audio extracted from an Artel-270 input. A DL1220 decoder operating on an SDI-formatted input signal does not require audio adjustments.

Purpose

A separate potentiometer is available for each of the four audio channels (A, B, C, and D) extracted from the Artel-270 input.

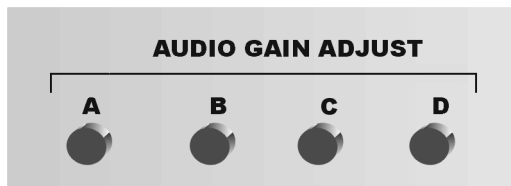

Figure 4-11. AUDIO GAIN ADJUST Potentiometers

The potentiometers enable you to adjust individual audio channel output levels, typically in the range +1.5 ... -2.0 dBm.

To adjust the gain on an audio channel:

1. Connect a test tone (such as +18 dBm) to an audio channel input on the encoder that is producing the Artel-270 input for the decoder.
2. Connect a video analyzer to the AUDIO MONITOR port on the decoder ([page 4-46](#)).
3. Select the corresponding audio channel (A, B, C, or D) on the decoder using the METER SELECT switch ([page 4-40](#)).
4. Measure the audio output on that channel at the decoder. Ensure the decoder output is terminated with a 600 Ω load.
5. Adjust the AUDIO GAIN ADJUST potentiometer until the decoder output is equal to the encoder test signal level.
 - To increase the audio signal level, turn the Audio Gain potentiometer clockwise.
 - To decrease the audio signal level, turn the Audio Gain potentiometer counterclockwise.
6. Repeat the above procedure for any other audio channels you need to adjust.



Data Outputs

Cabling the RS-232 DATA OUTPUTS Port

Location

The RS-232 DATA OUTPUTS port is a 25-pin female D-shell connector located on the decoder's rear panel (item 28 on [page 4-3](#)).

Input signal restrictions

This port is used by the decoder only when it has received an Artel-270 input signal from a DigiLink encoder. A DL1220 decoder operating on an SDI-formatted input signal does not extract data and does not provide outputs to this port.

Purpose

The RS-232 DATA OUTPUTS port can transmit up to eight RS-232 simplex data outputs that the decoder has extracted from an Artel-270 input signal. The port pinouts as follows:.

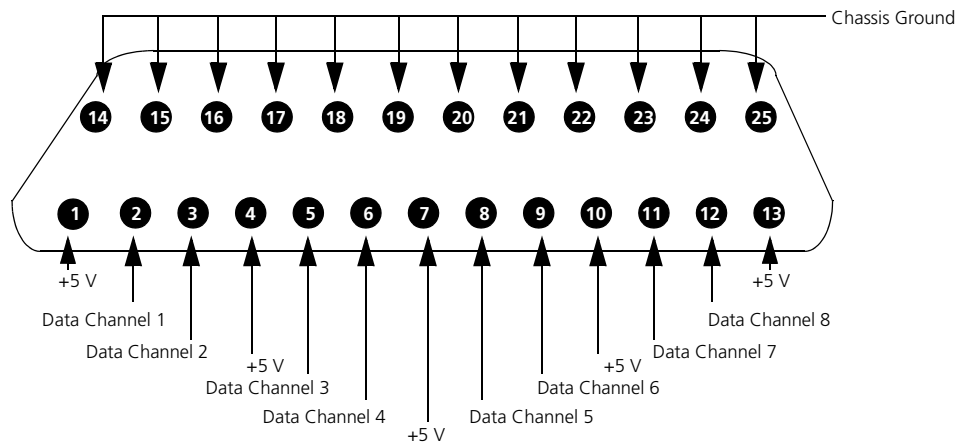

Figure 4-12. Pinouts for the RS-232 DATA OUTPUTS Connector

The +5 V pins enable you to bias one or more of the data channels to the HI or MARK state. Total short circuit output current for the +5 V pins is limited to 15 mA.

Note: The RS-232 port is for outputs only, and data transmission is in one direction only. If you have a bidirectional DigiLink installation, you can transmit RS-232 duplex data.

Data transmission rates from DC ... 19.2 kbaud are allowed. The data channels are baud- and protocol-transparent—i.e., no switch settings are required and all channels are independent.

Activity on the DATA OUTPUTS port is indicated by the DATA CHANNELS LEDs ([page 4-38](#)).

Cabling the RELAY Output Connectors

Location

Four relay contact closures, designated RELAY 1 ... RELAY 4, are located on the decoder's rear panel (item [29](#) on [page 4-3](#)).

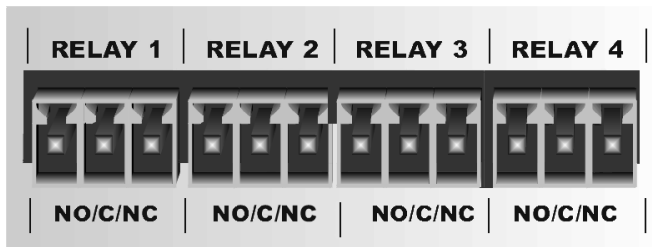

Figure 4-13. RELAY Output Connectors

Input signal restrictions

These connectors are used only when it has received an Artel-270 input signal from a DigiLink encoder. A DL1220 decoder operating on an SDI-formatted input signal does not provide outputs to these connectors.

Purpose

These relay contact closures can be connected to an external device and controlled by an encoder's RELAY inputs (see [page 3-28](#)). The encoder sends the relay control data to the decoder embedded in the Artel-270 transmission, and the decoder extracts the control data from its Artel-270 input signal.



A contact closure across the + and - pins on an encoder relay causes a contact closure at the receiving decoder relay. The decoder relays provide both normally open (NO) or normally closed (NC) contacts.

The relay contact rating is 48 VAC or VDC @ 100 mA. All relay contact pairs are isolated from chassis ground and from each other. Maximum applied voltage from any contact to chassis ground must be less than 100 VDC. The relay contacts are not polarity sensitive.

Note: All relays activate (the NO contacts close) when there is a total loss of system power or if the decoder does not receive a valid signal from the optical fiber (for example, a low-light or lock-lost condition).

To connect the relays to an external device

Use the three-pin removable screw wire clamp connectors shipped with the DigiLink. The connectors accept #24 ... #18 gauge twisted-pair wire.

Activity on the RELAY input connectors is indicated by the RELAY LEDs (page 4-38).

Cabling the ALARM RELAY Connectors

Location

Four three-terminal ALARM RELAY contact closures—two for local alarm status and two for remote alarm status—are located on the decoder's rear panel (items 24 ... 27 on page 4-3).

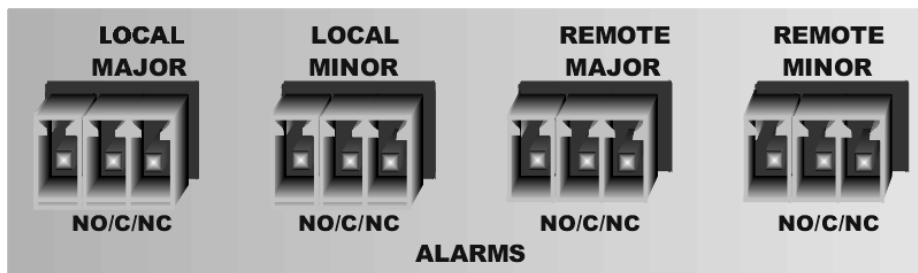

Figure 4-14. ALARM RELAY Connectors

Input signal restrictions

Information for the remote relays is available only when an Artel-270 input signal has been received by the decoder. Remote relay data is not encoded into an SDI input signal.

Purpose

These relays can be used to connect the decoder to external contacts, which can be activated when the decoder receives alarm conditions from the encoder or detects alarm conditions in itself. The four alarm relays convey status information about:

- Local major alarms
- Local minor alarms
- Remote major alarms
- Remote minor alarms

The remote relays reflect alarm states in the encoder. The local relays reflect alarm states in the decoder.

The alarm relays can be wired as normally closed (NC) contacts, in which case it will open when an alarm condition is sensed; or normally open (NO), in which case it will close when an alarm condition is sensed. All alarm relays go to the alarm state if there is a total loss of system power.

To connect an external coil to an alarm relay connector, use one of the three-pin removable screw wire clamp connector shipped with the DigiLink. The connector accepts #24 ... #18 gauge twisted-pair wire.

The relay contact rating is 48 VAC or VDC @ 100 mA. All relay contact pairs are isolated from chassis ground and from each other. Maximum applied voltage from any contact to chassis ground must be less than 100 VDC. The contacts are not polarity-sensitive.



Digital Audio Output

Cabling the SDI OUTPUT Port Location

The SDI OUTPUT port is a BNC connector located on the decoder's rear panel (item [31](#) on [page 4-3](#)).

Model and input signal restrictions

The SDI OUTPUT port is functional only on DL1220 decoders, and is used only to transmit SDI-formatted output signals. When a DL1220 decoder extracting analog video from an Artel-270 input signal, it does not use this port.

DL1200 decoders do not support SDI outputs. The port is present but disabled on these decoders.

Purpose

This port transmits an SDI-formatted digital output signal from a DL1220 decoder that has received an SDI input. The signal is transmitted over coaxial cable.

Setting the SCRAMBLE Switch

Location

The two-position SCRAMBLE switch is located on the decoder's rear panel (item [20](#) on [page 4-3](#)).

Model and input signal restrictions

This switch is functional only on the DL1220 decoders that are receiving SDI-formatted input signals. The switch is present but nonfunctional on the DL1200 decoders. The switch setting is ignored when the decoder is receiving an Artel-270 input signal.

Purpose

Turning ON the decoder's SCRAMBLE switch enables the decoder to descramble an SDI-formatted input signal so that it can be transmitted as an unscrambled digital output from the decoder.

The input signal must be an SDI signal that was scrambled with an Artel-proprietary algorithm before it was sent to the decoder. The input signal must be coming from an DL1220 encoder operating in SDI mode, and the encoder's SCRAMBLE switch ([page 3-29](#)) must be turned ON.

Caution

Whenever the input signal is coming from a DL1220 encoder operating in SDI mode, make sure that the SCRAMBLE switch setting on the decoder is the same as the switch setting on the encoder.

Note: A safe practice is to always set the SCRAMBLE switches on the encoder and decoder to the same setting.

Use this feature for a high-availability systems that need to be running constantly.

The PROTECTION SWITCH Port

Location

The PROTECTION SWITCH port is a 9-pin female D-shell connector located on the decoder's rear panel (item 23 on [page 4-3](#)).

Input signal restrictions

Automatic protection switching can be implemented only when NTSC, PAL, and SECAM input signals are being received by the decoder. These signals contain a negative sync pulse of approximately 40 IRE that can be detected by the decoder.

- Radar signals and certain scrambled video signals that do not contain normal horizontal sync pulses cannot use automatic switching
- SDI-formatted input signals cannot use automatic protection switching because they do not have an analog sync pulse for the decoder to detect

Purpose

In a protection switching configuration, two decoders are interconnected in a master/slave configuration. The connection is made via a standard 9-pin RS-232 null modem cable (with 9-pin, D-shell male-to-male connectors).

Use this feature for a high-availability systems that need to be running constantly. An application example is given on [page 5-7](#).



Using Internal and External Display Capabilities

Overview

Internal mechanisms

The decoder provides three on-board mechanisms that provide status information and alarm conditions:

- LEDs (see [page 4-36](#))
- The RECEIVER LIGHT LEVEL meter display (see [page 4-40](#))
- An audio alarm (see [page 4-44](#))

The LEDs on the front panel provide indications of system operating status, relay and data output availability, and output status.

The RECEIVER LIGHT LEVEL display is used in conjunction with the METER SELECT switch. Together they let you display status information about the decoder's optical wavelength, its internal operating temperature, and its audio input channels.

A built-in buzzer can be configured to sound whenever a major alarm condition is detected.

optional external devices

Two pairs of relays (see [page 4-31](#)) are also provided so that you can send major and/or minor alarm detection information to an external display. One set of relays provides local alarm status, and the other provides remote alarm status information about the encoder that transmitted the Artel-270 input signal.

Two monitor ports are also provided:

- A VIDEO MONITOR port (see [page 4-44](#))
- An AUDIO MONITOR port (see [page 4-46](#))

You can connect external display and analysis tools to the decoder via these ports.

Interpreting the Decoder Status LEDs

Location

The DigiLink decoder's front panel contains three groups of light-emitting diode (LED) indicators:

- A group of eight *device status* LEDs (item 3 on [page 4-2](#))
- A group of 12 *relay/data* LEDs (item 8 on [page 4-2](#)), described in more detail on [page 4-38](#)
- A group of four *output status* LEDs (item 11 on [page 4-2](#)), described in more detail on [page 4-39](#)

The device status LEDs indicate:

- When the decoder power is on
- When an alarm condition has been detected
- When the decoder is enabled and transmitting valid data

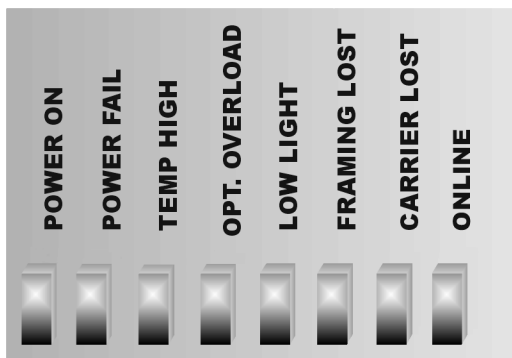

Figure 4-15. Device Status LEDs

[Table 4-3](#) describes their indications and the recommended response.

**Table 4-3. Device Status and LEDs**

Name	Color	State	Indication	Alarm Condition
POWER ON	Green	On	Main power is on	None
POWER FAIL	Red	On	One or more of the DC system voltages is out of tolerance	Major—unit must be serviced
TEMP HIGH	Red	On	Internal system temperature limit has been exceeded	Minor—possible causes: <ul style="list-style-type: none">• Fan failure• Ambient temperature too high• Poor air circulation
OPTICAL OVERLOAD	Yellow	On	Optical power level greater than -1.0 dBm	To reduce the optical power level, install an optical attenuator in series with the OPTICAL INPUT connector
LOW LIGHT	Red	On	Optical power level less than -32 dBm	Major—see the two notes below
<p>Note: On the DL1200DN decoders, which do not have optical support, the LOW LIGHT LED is not functional.</p> <p>Note: If you are receiving an input signal electrically rather than optically on a DL1200D, DL1220D, or DL1220DP decoder (all of which do support optics), the LOW LIGHT LED illuminates constantly but is not meaningful.</p>				
FRAMING LOST	Red	On	Decoder cannot detect framing in the input signal	Major—possible causes: <ul style="list-style-type: none">• Low light level• Video is not an NTSC signal• Change Mode software switch set to ANA while decoder is receiving an SDI input signal

Table 4-3. Device Status and LEDs (Continued)

Name	Color	State	Indication	Alarm Condition
CARRIER LOST	Red	On	Clock recovery circuit can not lock onto the incoming bit stream	Major—the bit rate is incorrect
ONLINE	Green	On	Decoder is enabled and is transmitting valid data.	None
		Off	Decoder is not transmitting valid data	Major
			Decoder is the slave in an automatic protection switching configuration	None
		Blinking	Audio framing error	

The relay/data LEDs indicate:

- Activity on the RELAY output connectors ([page 4-30](#))
- Activity on the RS-232 DATA OUTPUTS port ([page 4-29](#))

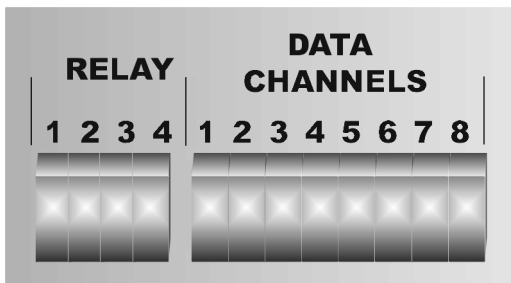

Figure 4-16. RELAY/DATA CHANNELS LEDs

Activity at these ports indicates that the decoder is extracting data from an Artel-270 input signal.

Note: A DL1220 decoder cannot extract relay or data outputs from an SDI-formatted input signal.



Table 4-4 describes the 12 LEDs.

Table 4-4. Relay/Data LEDs

Name	Color	State	Indication
RELAY (1 ... 4)	Green	On	Decoder is sending a relay contact closure as specified by the corresponding encoder relay input
DATA CHANNELS (1 ... 8)	Green	On	Decoder detects data transitions on the corresponding data from the encoder These LEDs are not status indicators. Data rates as low as 50 bits/s keep the LEDs on

The output status LEDs indicate:

- When the decoder has extracted an analog signal from the Artel-270 input and is transmitting it as the main video to its VIDEO OUTPUT port ([page 4-20](#))
- When an encoder is sending the test screen to its VIDEO OUTPUT port
- When the VIDEO SELECT switch ([page 4-17](#)) is set to AUTO

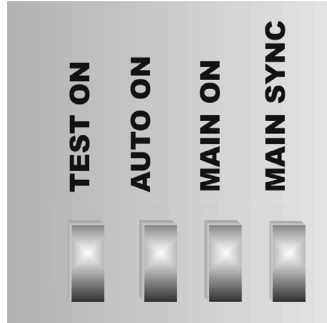

Figure 4-17. Output Status LEDs

Table 4-5 describes the four LEDs:

Table 4-5. Output Status LEDs

Name	Color	State	Indication
TEST ON	Yellow	On	Decoder is sending the test screen to the VIDEO OUTPUT port
AUTO ON	Green	On	VIDEO SELECT switch is set to AUTO
MAIN ON	Green	On	Decoder is sending the analog video signal to the VIDEO OUTPUT port
MAIN SYNC	Green	On	Decoder detects a sync pulse in the optical or electrical input signal

Using the METER SELECT Switch and the RECEIVER LIGHT LEVEL Display

Location

The RECEIVER LIGHT LEVEL display and six-position METER SELECT switch are located on the decoder's front panel (items 4 and 6, respectively, on [page 4-2](#)).

Purpose

The METER SELECT switch serves two purposes:

- To select the type of status information to be shown in the RECEIVER LIGHTLEVEL display
- To specify an audio channel output information to be analyzed by an external device connected to the AUDIO MONITOR connector ([page 4-46](#))



The METER SELECT switch in the AUDIO position:

Instructs the decoder to show the peak power level (in dBm) of the selected audio channel (A, B, C, or D) in the RECEIVER LIGHT LEVEL display. In the example below, the switch is set to audio channel C and the AUDIO LEVEL display shows its peak power level, -8.2 dBm.

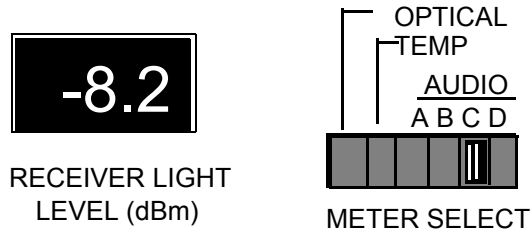

Figure 4-18. Receiver Light Level LED Display and Meter Select Switch

If you connect an external audio analyzer to the AUDIO MONITOR connector while the METER SELECT switch is set to C, the device will be able to analyze audio channel C.

Note: Audio channel information is of interest when the decoder is extracting output information from an Artel-270 input. Audio information cannot be extracted from an SDI-formatted input signal.

The METER SELECT switch in the TEMP position:

Causes the RECEIVER LIGHT LEVEL display to show the internal temperature of the decoder in degrees Celsius. Valid temperatures range from 0 ... 60° C).

If a temperature greater than 60° C is sensed, the TEMP HIGH LED is illuminated and a minor alarm is recorded (see [page 4-36](#)).

The METER SELECT switch in the OPTICAL position:

Causes the RECEIVER LIGHT LEVEL display to show the decoder's optical input power (in dBm). Valid power is in the range is 0 ... -40 dBm and is displayed in increments of 0.1 dBm.

Displaying the Change Mode software switch status

The RECEIVER LIGHT LEVEL display can also be used to show the current setting of the Change Mode software switch ([page 4-11](#)). If you do not have a video monitor attached to the decoder, you can still view and change this switch parameter via the display and the buttons on the decoder's front panel ([page 4-47](#)).

- If the decoder is receiving an Artel-270 input signal, the Mode Select switch should be set to ANA
- If the (DL1220) decoder is receiving an SDI-formatted input signal, the Change Mode switch may be set to either SDI or EDH

Caution

EDH mode should be selected only when the signal that the DL1220 decoder is receiving is an SDI signal in SMPTE 259M format. Problems will occur in the electrical output from the decoder if any other signal type is used.

To view the current Change Mode setting, push the <PGRM> button. The RECEIVER LIGHT LEVEL display indicates the current switch setting (ANA, SDI, or EDH) for approximately 1.5 s.

Changing the Change Mode software switch setting

If a DL1220 decoder is receiving an SDI-formatted input signal when the Change Mode switch is set to ANA, the decoder can still output the SDI signal but it will also trigger a FRAMING LOST major alarm. You can disable this major alarm by toggling the Change Mode switch from ANA to SDI (or EDH, if appropriate).

Setting the Change Mode switch to SDI or EDH, in effect, masks the framing of the input signal and disables the decoder's ability to detect a framing error. This operating condition is useful only in a DL1220 decoder that is handling SDI-formatted inputs.

Caution

If the decoder is extracting analog video from an Artel-270 input and the Change Mode software switch is set to SDI or EDH, the decoder will still be able to output analog video but it will not be able to trigger FRAMING LOST alarm conditions even when there are real framing errors in the input signal. In the case of EDH, problems will also occur in the electrical output from the decoder.



To toggle the Change Mode setting:

1. Press <PGRM> once.

Result: The RECEIVER LIGHTLEVEL display shows the current setting (either ANA or SDI) for approximately 1.5 seconds.

Note: If <PRGM> was pushed before you started the procedure or if you inadvertently push it more than once in step 1, the program function goes into an unknown mode and this switch toggling procedure will not work. If the Change Mode switch setting does not appear in the RECEIVER LIGHT LEVEL display, you have two choices:

- Connect a video monitor to the decoder and set the MONITOR SOURCE SELECT switch to TEST VIDEO ([page 4-45](#)). With the monitor, you can see what state has been selected and exit from the menus appropriately.
- In the event that a video monitor is not available, you can cycle power on the decoder to reset the program to a known condition. At this point, the switch toggling procedure will work as described here.

2. Push <Enter>.

Result: The switch setting toggles (from ANA to SDI or from SDI to ANA). The RECEIVER LIGHT LEVEL display shows the new setting for approximately 1.5 seconds.

3. Push <PGRM> again.

Result: The new switch setting is saved and shown in the RECEIVER LIGHT LEVEL display for another 1.5 seconds.

Configuring the AUDIBLE ALARM

Location

The two-position AUDIBLE ALARM switch is located on the decoder's front panel (item 9 on [page 4-2](#)).

Purpose

Use this switch to enable or disable the decoder's internal alarm buzzer. When enabled, the buzzer is activated when the decoder detects a major alarm condition.

- When the switch is in the ON position, the audible alarm buzzer will sound when a major alarm is detected
- When the switch is in the OFF position, the audible alarm buzzer does not sound when a major alarm is detected

Monitoring Video and Audio Signals

Wiring the VIDEO MONITOR Port

Location

The VIDEO MONITOR port is a BNC connector on the decoder's front panel (item 16 on [page 4-2](#)).

Purpose

Use this port to connect an external device such as a waveform analyzer, a vector scope, a bit analyzer (for digital video), or a video monitor to the decoder.

Note: For accurate measurements, terminate the signal with 75 ohms.

You can display your choice of analog video, digital video (if you are using a DL1220 decoder with an SDI-formatted input signal), or a test screen on the VIDEO MONITOR port—use the MONITOR SOURCE SELECT switch ([page 4-44](#)) to specify the type of signal you want sent to the port. If you want to send analog video, you also need to configure the VIDEO SELECT switch ([page 4-17](#)) appropriately.



Configuring the MONITOR SOURCE SELECT Switch

Location

The three-position MONITOR SOURCE SELECT switch is located on the decoder's front panel (item 17 on [page 4-2](#)).

Purpose

Use this switch to select the type of signal that the decoder will output to its VIDEO MONITOR port ([page 4-44](#)). It has three settings:

- MAIN VIDEO - Displays the main video source from the OPTICAL INPUT port
- DIGITAL VIDEO (DL1220 decoders only)- Displays SDI video from the SDI INPUT port
- TEST VIDEO - Displays a test screen, either the default test pattern or the customized test screen created with the Test Screen editor ([page 4-47](#))

When the MONITOR SOURCE SELECT switch is set to MAIN VIDEO:

The decoder sends the main video signal to the VIDEO MONITOR port whenever it is available. Main video is available when both of the following conditions are met:

- The VIDEO SELECT switch ([page 4-17](#)) is set to MAIN or AUTO
- The output signal is analog video extracted by the decoder from an Artel-270 input signal

If the main video is not available, the decoder sends a test screen to the VIDEO MONITOR port.

When the MONITOR SOURCE SELECT switch is set to DIGITAL VIDEO:

- If the DL1220 decoder is receiving an SDI-formatted input signal, it sends a digital video signal to the VIDEO MONITOR port
- If the DL1220 decoder is extracting analog video from an Artel-270 input signal and the VIDEO SELECT switch is set to MAIN or AUTO, it sends the analog video to the VIDEO MONITOR port

If neither an SDI video nor a main video is available, the DL1220 decoder sends a test screen to the VIDEO MONITOR port.

Note: If you are using a DL1200 decoder, the DIGITAL VIDEO switch position is disabled.

When the MONITOR SOURCE SELECT switch is set to TEST VIDEO:

The decoder constantly sends a test screen to the VIDEO MONITOR port. The test screen may be the default screen provided with the encoder or a custom screen you have developed with the Test Screen editor ([page 4-47](#)).

Wiring the AUDIO MONITOR Port

Location

The three-terminal AUDIO MONITOR connector is located on the decoder's front panel (item 18 on [page 4-2](#)).

Mode restrictions

The decoder can extract audio outputs only from Artel-270 input signals. SDI-formatted input signals do not provide embedded audio signals.

Purpose

This port allows you to connect an external audio analyzer to the decoder. Use the METER SOURCE SELECT switch ([page 4-40](#)) to specify the audio channel (A, B, C, or D) that you want to analyze.

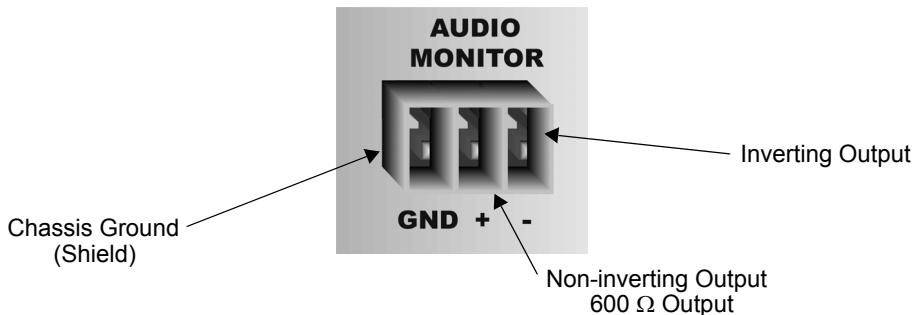

Figure 4-19. Decoder Front Panel Audio Monitor Connector

For accurate measurements, terminate the wire attached to the audio channel connector with 600 Ω.



Using the Test Screen Editor

Location

Physically, the Test Screen editor comprises four buttons located on the decoder's front panel (item 5 on [page 4-2](#)):

- <PGRM>
- <UP>
- <DOWN>
- <ENTER>

These buttons give you access to a series of menus and editing capabilities within those menus. To operate the editor, connect the decoder to an external monitor.

Purpose

The decoder stores a test screen, which it can output to the VIDEO MONITOR port ([page 4-44](#)) or one of the signal output ports (see [page 4-17](#)). The Test Screen editor gives you the ability to customize your test screen.

You can generate up to five lines of displayed text and choose from a series of test pattern backgrounds. A preview of the test pattern you select and text you enter is displayed on the monitor as you generate them.

The Test Screen editor works independently of the decoding/transmission functions. The decoder continues to function while you are accessing the editor menus.

The default test screen

A default test screen is provided in the decoder. It will be displayed on the monitor if you do not customize a new test screen with the Test Screen editor.

- If you are using any DigiLink decoder except the DL1220DP or DL1220DP-48, the Color Bars test pattern is the default test screen
- If you are using a DigiLink DL1220DP or DL1220DP-48 decoder, the Luma Bars 3 test pattern is the default test screen

Editor timeout

The Test Screen editor has a 5 min timeout feature. If you have initiated the editor and do not take any action for 5 minutes, it times out.

If you have selected a new test pattern or saved one or more lines of text, they will be output to the VIDEO MONITOR port after:

- You exit the editor menus
- The editor times out



The Test Screen editor buttons

Table 4-6 defines the functions of the four Test Screen editor buttons.

Table 4-6. User Interface Buttons and Functions

Button	Enables you to...
<PGRM> (program)	<ul style="list-style-type: none">• Initiate the User Interface• Change <UP> and <DOWN> to scrolling character selection cursors in text entry mode• Activate the text entry feature
<UP>	<ul style="list-style-type: none">• Move the arrow cursor up• Move the arrow cursor from left to right (after you push <PGRM> to change the button function)
<DOWN>	<ul style="list-style-type: none">• Move the menu cursor down• Toggle the character cursor between the upper and lower character rows (after you push <PGRM> to change the button function)
<ENTER>	<ul style="list-style-type: none">• Select an alphanumeric character from a character line in the Text Entry menu• Increment the line number displayed in the Line Selected option of the Text Entry menu• Select a menu option.• Toggle the Change Mode setting on the Main menu

The Test Screen editor's menu structure

Figure 4-20 is a flowchart of the decoder's Test Screen editor menus. They can be viewed on the attached monitor when you push <PRGM>.

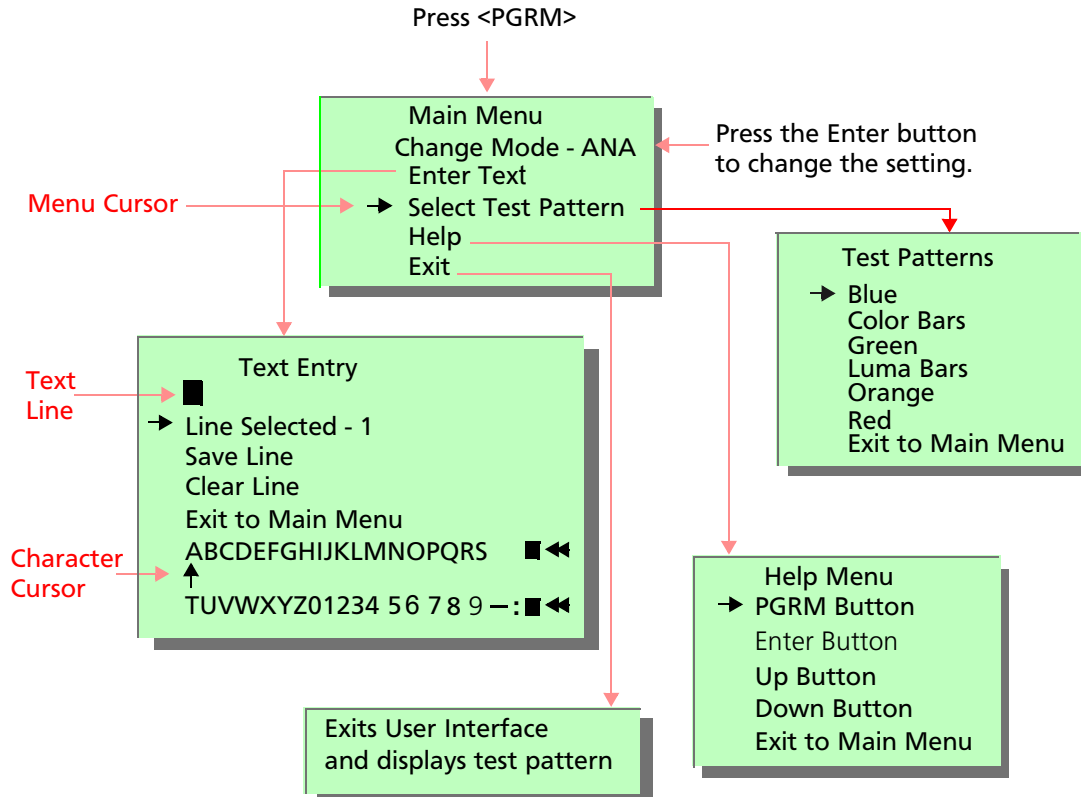

Figure 4-20. User Interface Menu Flowchart

Note: The Test Patterns menu shown below displays NTSC test patterns. Refer to [page 4-60](#) for a description of the PAL test patterns.

**To operate the Test Screen editor:**

1. Connect a monitor to the VIDEO MONITOR port (page 4-44).
2. Set the MONITOR SOURCE SELECT switch (page 4-40) to TEST VIDEO.
3. Push <PRGM>.

Using the Main Menu

The Main menu options enable you to perform the actions defined in Table 4-7.

Table 4-7. Main Menu Options

Moving the cursor to...	Enables you to...
Change Mode	Toggle the setting between ANA, SDI, and EDH.
Enter Text	Display the Text Entry menu.
Select Test Pattern	Display the Test Patterns menu.
Help	Display Help screens for the User Interface buttons.
Exit	Exit the User Interface and display the programmed test pattern and text.

To access the Main menu push <PRGM>. The Main menu appears with a particular mode indicated:.

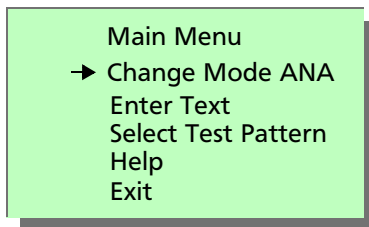
**Figure 4-21. Main Menu**

To select a Main menu option:

1. Position the cursor arrow next to the option you want to select. The cursor can be moved by pushing <UP> or <DOWN>.
2. Push <ENTER>.

Result: If you have selected Change Mode, Enter Text, Select Test Pattern, or Help, the menu associated with that option will appear on the monitor. If you have selected Exit, the programmed test pattern and any previously saved text will appear.

Using the EDH Monitor

If you enter EDH mode, an additional entry—EDH Monitor—appears as the top item in the Main Menu.

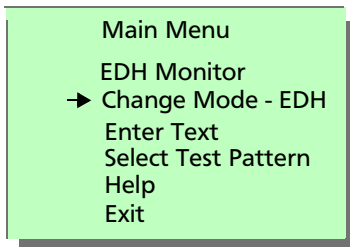

Figure 4-22. Main Menu Screen When EDH Mode is Selected

Caution

EDH mode should only be used when the incoming signal from the transmitter end is SMPTE259 compliant—if not, the electrical output will not function as intended.

If the decoder is receiving an Artel-270 input and the Change Mode software switch is set to EDH, the decoder will be able to output analog video, but will ignore any framing errors.

If the decoder is receiving another SDI signal type (such as DVB-ASI)



and the Change Mode software switch is set to EDH, the encoder-decoder link will fail.

If you move the Menu cursor to the EDH Monitor selection and push <ENTER>, a special error detection handling display appears on the monitor. This screen provides several lines of status information and error flags, as shown in [Figure 4-23](#).

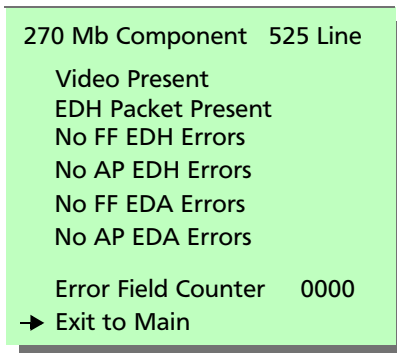

Figure 4-23. An EDH Screen with No Errors Detected

When no error conditions are detected, the screen background is green, and the nine entry lines read similarly to the ones shown above in [Figure 4-23](#).

- The first entry in the top line is a fixed text string that tells you that the signal being received by the decoder is *270 Mb Component SDI*
- The second entry in the top line indicates whether the received signal is in NTSC or PAL format—it reads *525 Line* when the signal is NTSC and *625 Line* when the signal is PAL
- The entry on the second line states that video is present in the received signal and that it is in SMPTE 259M-C 4:2:2 format
- The entry on the third line tells you that an RP-165M EDH packet is present in the received signal—the presence of an EDH packet is optional in an SMPTE 259M-C 4:2:2 video signal
- The next four entries are error flags that can be used to isolate the location of a detected error:
 - *FF* refers to the *full field*, meaning not only the active picture area of the signal but the blanking areas as well—the blanking area can include, among other things, the audio, data, and EDH content of the signal

- *AP* refers to the *active picture* area in the received signal
- *EDH*, in the context of these entries, means *error detected here*—this indicates that the error has been detected in the decoder that is receiving the signal
- *EDA* means *error detected already*—this indicates that the error was detected down-stream before it reached the decoder

These four flags are set only when there is video present that contains the EDH packet.

- The entry on the eighth line is an *error field counter*, which increments each time an the error detection handler triggers an error flag; this counter increments up to a count of 9999, both in this screen and on the RECEIVER LIGHT LEVEL window, after which it displays an *OVFL* overflow message
- The entry on the last line allows you to escape back to the Main Menu

If an error is detected, three things happen:

- The screen background turns red
- The text string in the entry that describes the error changes
- The entry that describes the error becomes right-justified on the screen

For example, if the received signal does not conform with SMPTE 259M-C, the screen will look like this:

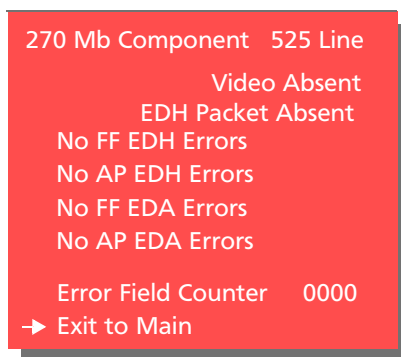

Figure 4-24. An EDH Screen with an Invalid Video Signal



The text in the entries on the second and third lines changes to indicate that video is absent and that therefore the EDH packet is also absent. These two entries are now right-justified, and the screen background color has changed to red.

Note: The *Video Absent* and *EDH Packet Absent* conditions do not cause any of the four error flags on lines 4 ...7 to trigger, and they do not increment the error field counter.

When the video is present and the EDH packet is present in the received signal, the EDH capability will constantly monitor the signal for errors in accordance with SMPTE RP165. If any of the four flags on lines 4 ...7 is triggered, you will be able to identify, at least in general terms, where the error has originated. For example, suppose a screen like the one shown in [Figure 4-25](#) appears:

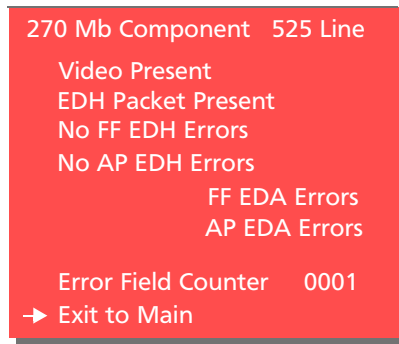

Figure 4-25. An EDH Screen with a Downstream Error Detected

This screen informs you that an error has been detected in the active picture area of the received signal and that it was detected downstream—before it was received by the decoder. The error detection handler also causes the error counter field to increment to 0001.

When an error is detected, the screen background turns red and the associated error flag is triggered. The error flag latches on to a single event. Additional errors will continue to increment in the error field counter as they are detected. The screen background will remain red and the error flag will remain triggered until the screen is cleared. To clear the screen, move the METER SELECT switch to the A, B, C, or D position, then back to the left (OPTICAL) position. When you do this, the screen will return to its normal green background color.

Note: Unlike the other screens in the Test Editor, this EDH screen does not automatically time out. You must execute an *Exit to Main* operation to get out of this menu and return to the top. The menu-select cursor is fixed on the Exit to Main entry, enabling you to exit the EDH menu at any time by simply pressing <PGRM>. Keep in mind that you need to push the <PGRM> button only once to return to the Main Menu—pushing it once more will exit the menus.

Entering Text

When you select Text Entry from the Main menu, the following menu appears on the monitor:

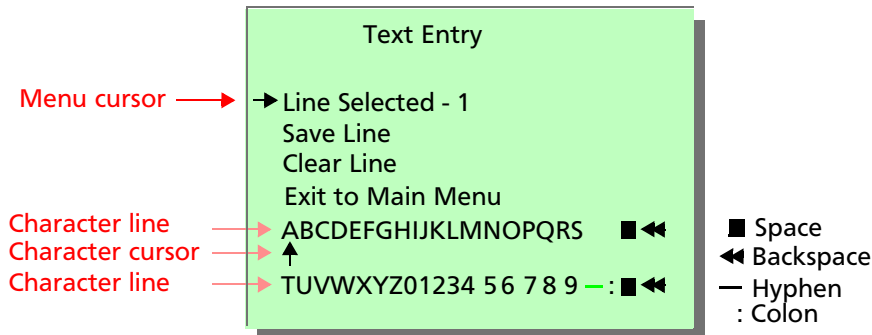

Figure 4-26. Text Entry Menu

With this menu, you can enter up to five line of alphanumeric text, with up to 24 characters per line. The text is previewed on the monitor as you enter it. You can clear existing lines of text from the test screen and save newly entered text lines to the test screen. [Table 4-8](#) describes the Text Entry menu options.

Table 4-8. Text Entry Menu Options

Option Name	Enables you to...
Line Selected	Display the text line (1 ... 5) to create, save, or clear.
Save Line	<ul style="list-style-type: none"> Save the text line displayed in the Text Entry menu. When you save a text line, the line displays as reverse video for approximately 3 s. Save a cleared line from the test pattern display.

**Table 4-8. Text Entry Menu Options**

Option Name	Enables you to...
Clear Line	Clear the text line displayed in the Text Entry menu. To clear the text line permanently (that is, clear the text from the test pattern display) save the change using the Save Line option.
Exit to Main Menu	Close the menu and display the Main menu.

Using the Text Entry Cursors

The Text Entry menu contains two cursors:

- A *menu cursor*, which appears as a horizontally pointing arrow that moves <UP> or <DOWN> beside the four menu options and beside the character lines at the bottom of the menu.
- A *character cursor*, which appears as a vertically pointing arrow that moves horizontally along the two rows of alphanumeric characters at the bottom of the menu

Only one cursor is active at a time. By default, the menu cursor is always active when you first access the menu.

To activate the character cursor, position the menu cursor next to a character line and push <PGRM>. To reactivate the menu cursor, push <PGRM> again.

To select a line:

1. Use <UP> or <DOWN> to position the menu cursor beside the Line Selected option.

The currently selected line number (1 ... 5) is displayed beside this menu option. Any text currently on that line (unsaved from this session or saved from this or a previous session) is displayed at the top of the menu.

2. If you want to enter text on a line other than the currently selected line, push <ENTER> to increment the line number. <ENTER> increments from 1 ... 5, then wraps from 5 back to 1.

3. Once the desired line number has been selected, you may save the text that is currently on it, clear the text on it, or enter new text on it.

Push <Down> to position the menu cursor next to the character rows (to enter text) or the desired menu option (to save or clear text).

To enter text:

1. Select the line you want to enter text on using the procedure on [page 4-57](#).
2. Position the menu cursor next to a character line and push <PGRM>.

Result: The menu cursor disappears and the character cursor appears as a vertical arrow between the two rows of characters. Also, <UP> now functions as a horizontal scrolling mechanism for the character cursor, and <DOWN> functions as a toggle between the upper or lower rows of characters.

3. Select the first character you want to enter by pushing <UP> to scroll from left to right across the character columns.

When the character cursor arrow is pointing up, you can select characters from the top row. When it is pointing down, you can select from the bottom row.

Push <DOWN> if you need to toggle the character cursor between character rows. The character that is currently being pointed to by the character cursor is displayed to the left of the character rows.

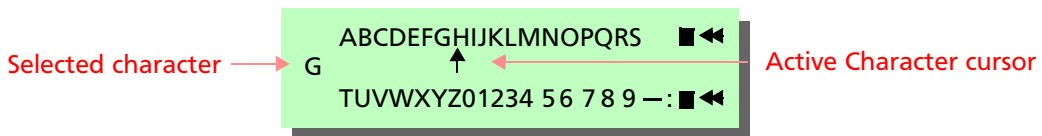

Figure 4-27. Active Text Entry Feature and Character Cursor

4. When the character cursor is pointing to the character you want, push <ENTER>.
5. Select the next character you want to enter, repeating steps 3 and 4 for each character entry.

Pushing <UP> scrolls only from left to right. If you want to select a character to the left of the currently positioned character cursor, you must scroll all the way to the right of the row and push <UP> again to wrap back to the left side of the row.



If you want to delete a character that you have entered on the selected line, move the character cursor to the backspace symbol— and push <UP>.

Result: The cursor backspaces from right to left, deleting each character that it moves back over.

6. When the text line is complete, push <PGRM> to reactivate the menu cursor. You may now either save or clear the line. If you exit the editor without saving the line, it will be cleared automatically.
7. Save the text line by selecting the Save Line option and pushing <ENTER>.

To save a text line

1. Select the line you want to save using the procedure on [page 4-57](#).

The (saved and unsaved) text on that line is displayed at the top of the Text Entry menu.

2. Position the menu cursor next to the Save Line option and push <ENTER>.

While being saved, the line is displayed in reverse video for approximately 5 s.

To save a line or save a cleared line, place the cursor next to the Save Line option and push <ENTER>. When you save a text line, the line displays as reverse video for approximately 3 s.

To clear a text line:

1. Select the line you want to save using the procedure on [page 4-57](#).

The (saved and unsaved) text on that line is displayed at the top of the Text Entry menu.

2. Position the menu cursor beside the Clear Line option and push <ENTER>.

Result: The unsaved text is deleted. Previously saved text is cleared from the Text Entry menu but remains in the test screen display.

3. To permanently clear the previously saved text line from the test screen display, position the menu cursor beside the Save Line option and push <ENTER>.

Result: The text line is overwritten by the empty line in the Text Entry menu.

Programming a Test Pattern

When you select Test Patterns from the Main menu one of the following two menu screens will appear on the monitor. The Test Pattern menus differ on different versions of the decoder.

If you are using any DigiLink decoder except the DL1220DP or DL1220DP-48, the following NTSC Test Pattern menu will appear on the monitor:



Figure 4-28. NTSC Test Patterns Menu

If you do not select an alternate test pattern, the Color Bars test pattern appears on your test screen by default.

If you are using a DigiLink DL1220DP or DL1220DP-48 decoder, the following PAL Test Pattern menu will appear on your monitor:

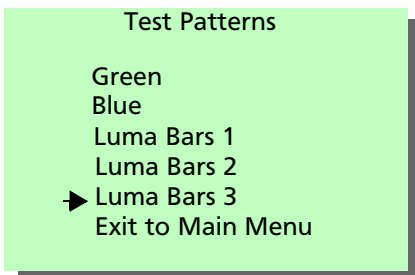

Figure 4-29. PAL Test Patterns Menu



If you do not select an alternate test pattern, the Luma Bars 3 test pattern appears on your test screen by default.

To select a test pattern:

1. Use <UP> or <DOWN> to position the menu cursor beside the desired test pattern.
2. Push <ENTER>.

Result: The selected test pattern appears on the monitor display immediately and is saved automatically.

Getting Help

When you select Help from the Main menu, the following menu screen appears on the monitor:

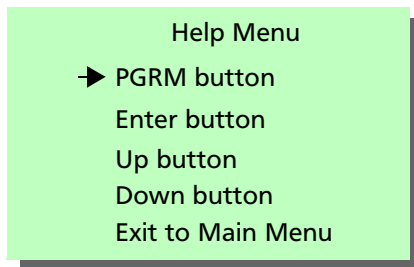

Figure 4-30. Editor Buttons Help Menu

From this menu, you can go to help text describing the Test Screen editor buttons.

To display a Help menu for a User Interface button:

1. Use <UP> or <DOWN> to position the menu cursor beside the button you want Help on.

2. Push <ENTER>.

Result: A Help screen appears. [Figure 4-31](#) ... [Figure 4-34](#) illustrate the associated Help screens.

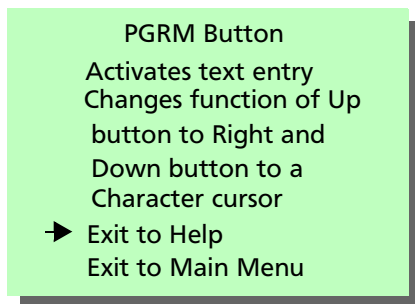

Figure 4-31. <PGRM> Help Screen

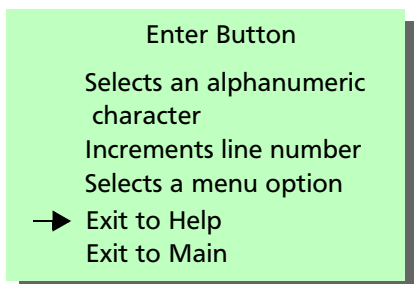

Figure 4-32. <ENTER> Help Screen

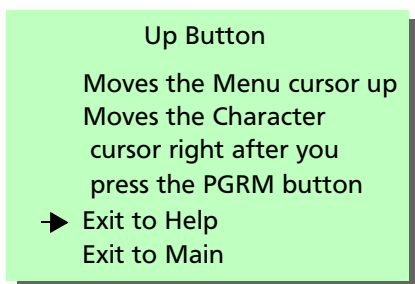

Figure 4-33. <UP> Help Screen

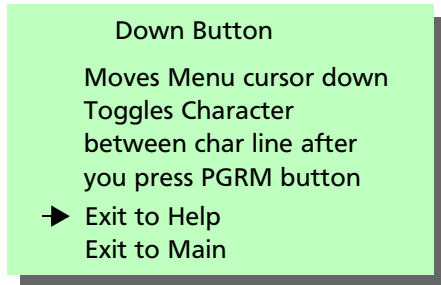

Figure 4-34. <DOWN> Help Screen

3. To go back to the Help Menu screen, move the menu cursor beside Exit to Help and push <ENTER>.
To go back to the Main Menu screen, move the menu cursor beside Exit to Main and push <ENTER>.

When you select Help from the Main menu, the following menu screen appears on the monitor:

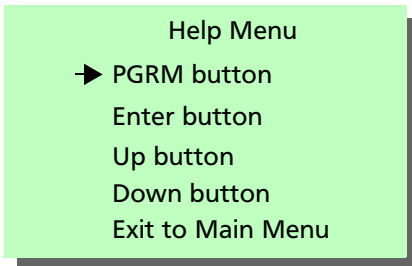

Figure 4-35. Editor Buttons Help Menu

From this menu, you can go to help text describing the Test Screen editor buttons.

To display a Help menu for a User Interface button:

1. Use <UP> or <DOWN> to position the menu cursor beside the button you want Help on.
2. Push <ENTER>.

Result: A Help screen appears. [Figure 4-36](#) ... [Figure 4-39](#) illustrate the associated Help screens.

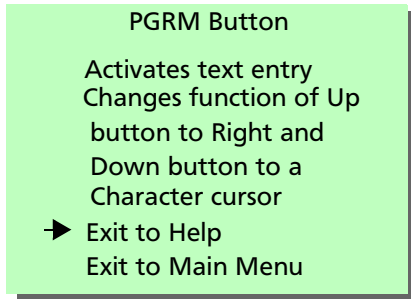

Figure 4-36. <PGRM> Help Screen

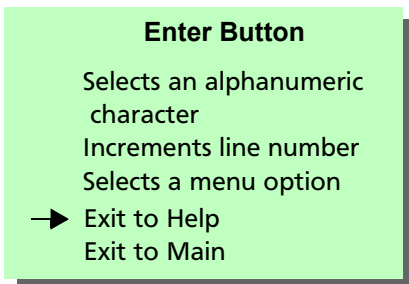

Figure 4-37. <ENTER> Help Screen

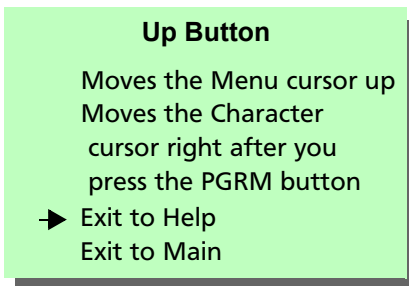

Figure 4-38. <UP> Help Screen

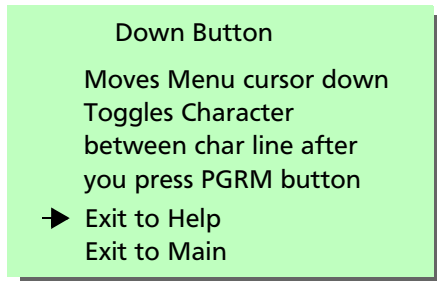

Figure 4-39. <DOWN> Help Screen

3. To go back to the Help Menu screen, move the menu cursor beside Exit to Help and push <ENTER>. To go back to the Main Menu screen, move the menu cursor beside Exit to Main and push <ENTER>.



5

Configuration Applications

This chapter provides sample configurations that illustrate how to use the DigiLink encoders and decoders in the following types of applications:

- [A Point-to-point Configuration \(page 5-2\)](#)
- [Using a Routing Switcher on the Electrical Link \(page 5-3\)](#)
- [Analog and Digital Switch Bridging \(page 5-4\)](#)
- [Dual Services Switched Network \(page 5-5\)](#)
- [Using the Encoders and Decoders for Critical Applications \(page 5-6\)](#)
- [Implementing Protection Switch Configurations \(page 5-7\)](#)

A Point-to-point Configuration

Figure 5-1 illustrates point-to-point communication between a DigiLink 1220 encoder and decoder.

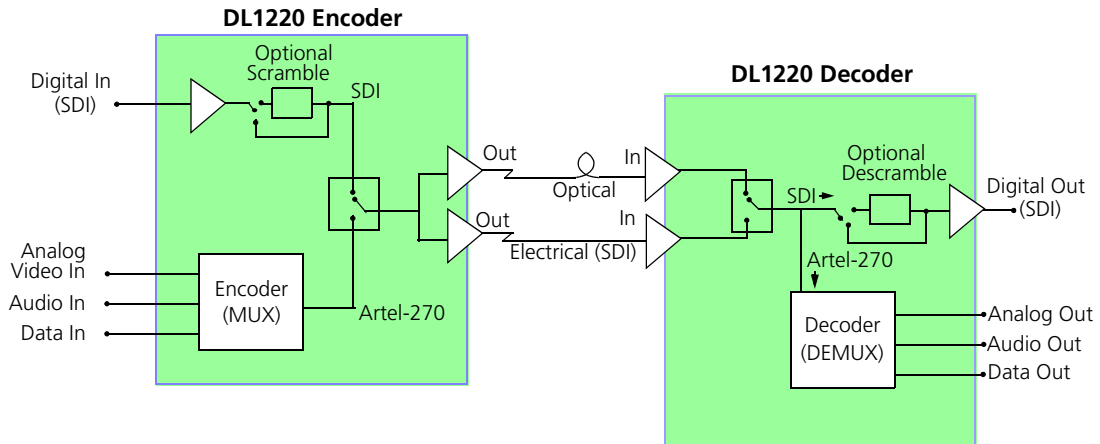

Figure 5-1. Encoder/decoder Point-to-point Configuration

The DL1220 encoders can transmit analog video as part of its Artel-270 output or digital video as an SDI-formatted output. They can transmit either output type point-to-point with a DL1220 decoder via the encoder's OPTICAL OUTPUT port or SDI (electrical) OUTPUT port.

Generally, in a point-to-point configuration the optical link is preferred because of the length restrictions associated with an electrical link. When an encoder transmits electrically over coaxial cable, its target device must be within 250 m (800 ft).

By contrast, an encoder transmitting over an optical link can communicate point-to-point with a decoder for distances of 60 km (36 mi) or more, depending on the type of laser and the quality of the fiber cable.

Any DigiLink encoder can provide optical outputs to a decoder. Most models have a built-in laser, and for those models that do not (the DL1200EN, DL1200DN, and DL1220EN models), optional laser cartridge support is available.

Usually, when the SDI OUTPUT port is used (to transmit the output electrically), a routing device is placed between encoders and decoders to provide a digital switching network, as described in the following section.



Using a Routing Switcher on the Electrical Link

Figure 5-2 illustrates several DigiLink DL1200 encoders transmitting Artel-270 via their electrical output ports through a Utah Scientific UTAH-300 Routing Switcher System to several DL1200 decoders.

Through a series of switches, the routing switcher directs the Artel-270 signals it receives (from the encoder) to any or all of the decoders, using a hierarchy and timing scheme you program into the routing system.

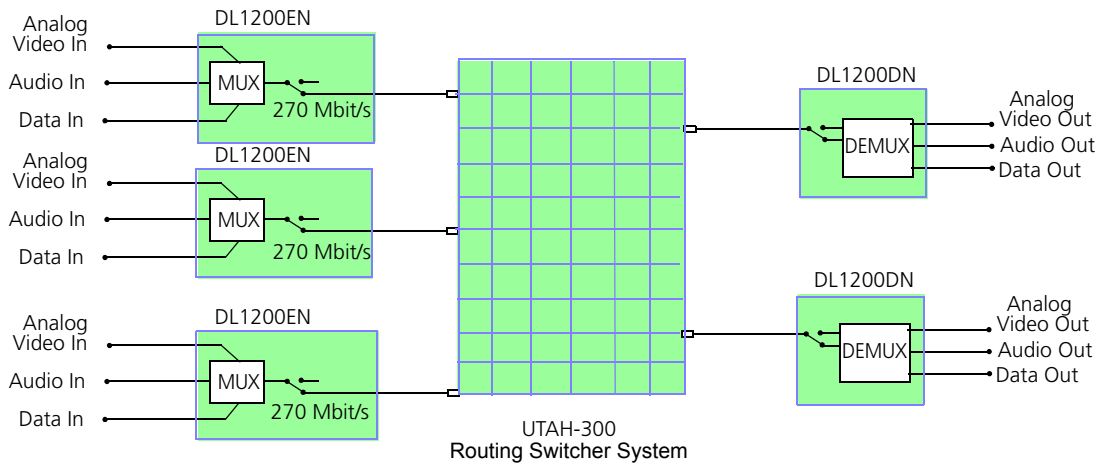

Figure 5-2. DigiLink DL1200EN and DL1200DN Configuration

A video transport system that uses these routing switchers needs to use the electrical link. UTAH-300 Routing Switchers accept inputs and transmit outputs over coaxial cable. The digital signal coming from the encoder is fully regenerated at the switching center. As long as each destination device is within 250 m (800 ft) of its source device, signal quality will not degrade, even when the signal is routed through a large hierarchy of switching centers.

Note: As indicated in Figure 5-2 above, the routing switcher accepts the input signal at a data rate of 270 Mbit/s. When you are using Utah Routing Switchers in your video transport system, make sure that the DATA RATE MBPS switch on your encoders (item 38 in Figure 3-2 on page 3-3) is set to 270. A DigiLink encoder *cannot* communicate with a Utah Routing Switcher at 269.2 Mbit/s.

Analog and Digital Switch Bridging

The DigiLink DL1200EN and DL1200DN provide a cost-effective bridge between the analog and digital video worlds. To bridge an analog and digital switch, create a configuration with an Artel MegaLink 1290X digital video transceiver, a DL1200EN to bridge an analog switch port to a digital switch port, and a DL1200DN to bridge a digital switch port to an analog switch port.

Figure 5-3 illustrates how to bridge an analog and digital switch using the DL1200EN, DL1200DN, MegaLink 1290X Transceiver, and Utah Scientific UTAH-300 Routing Switcher System.

By connecting a DL1220E and DL1220D to the MegaLink 1290X transceiver, you can provide a D1 transport component to your network.

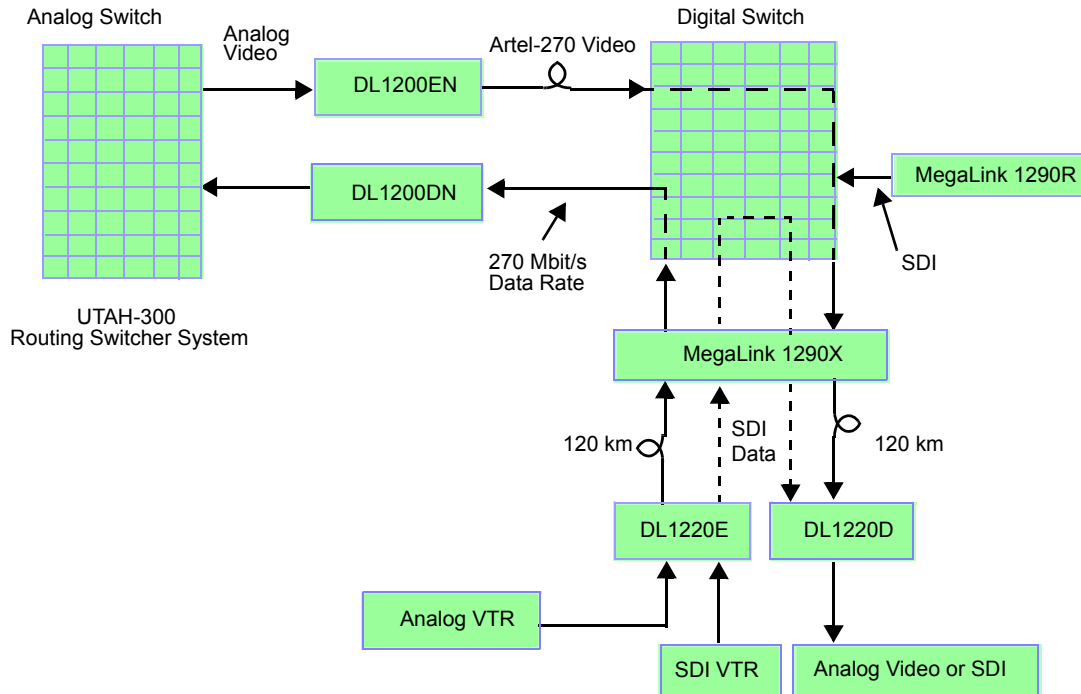

Figure 5-3. Bridging an Analog and Digital Switch



Dual Services Switched Network

When you use the DigiLink DL1220E and DL1220D in a switched network topology, the products provide you with a high degree of equipment and fiber efficiency, as well as configuration flexibility. The significance of the DL1220E and DL1220D is that in addition to using the same transport equipment, switch partitioning between analog and digital video is no longer required because the DL1200D decoder determines the incoming signal type.

For both analog and digital transport and switching, you can employ any industry-standard SMPTE 259M-C routing switcher (for example, the UTAH-300 Routing Switcher System) to route digital video signals in addition to analog video signals in the digital domain. [Figure 5-4](#) illustrates the DL1220E and DL1220D in a dual service switched network employing an Artel MegaLink 1290 digital video transmission system transceiver and a UTAH-300 Routing Switcher System.

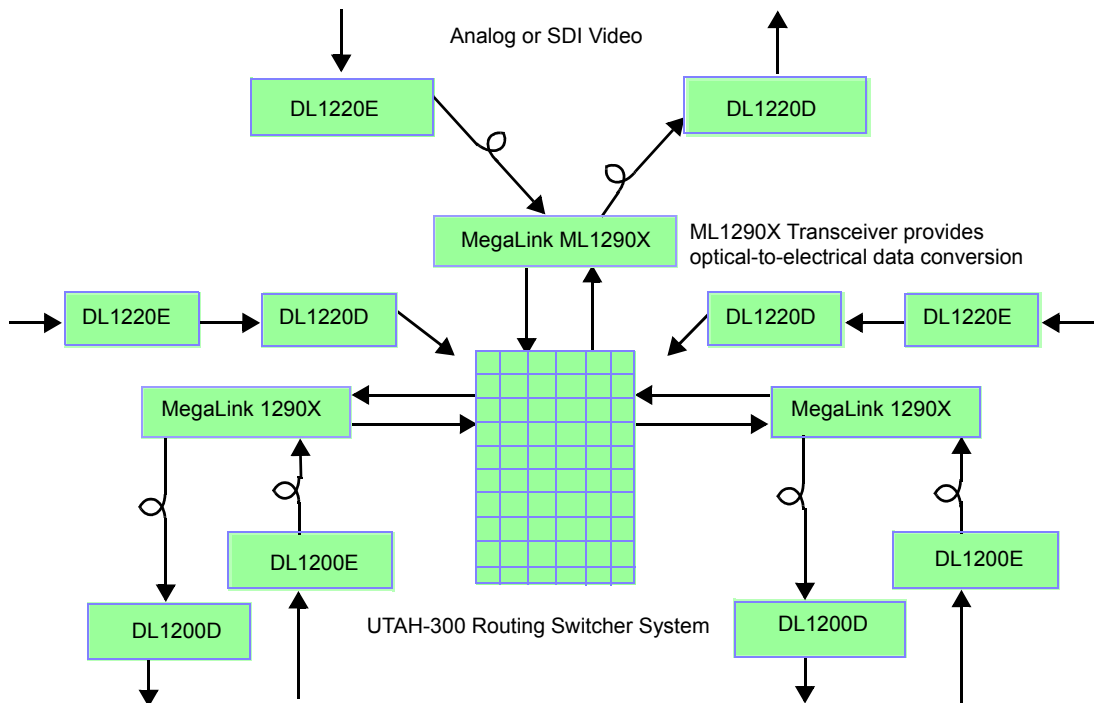

Figure 5-4. DL1220E and DL1220D in Dual Service Switched Network

Using the Encoders and Decoders for Critical Applications

You can use a second DigiLink encoder and decoder to employ route diversity and to provide automatic protection switching for critical applications.

By connecting the protection switch ports of the decoder units together (using a standard 9-pin RS-232 null modem cable), the first decoder to acquire a valid signal becomes the master, the second decoder becomes the slave. If a master decoder experiences a fault (for example, loss of optical input, loss of data lock, or power failure) it reverts to slave mode and the second decoder (if it is not experiencing a fault) becomes the master.

Note: Automatic protection switching functions only with NTSC, PAL, and SECAM signals containing a negative sync pulse of approximately 40 IRE. Radar signals and certain scrambled video signals that do not contain normal horizontal sync pulses cannot use automatic switching.

Automatic protection switching does not apply to SDI (such as D1) because no analog sync pulse exists for the decoder to detect.

To interconnect the DigiLink decoders, use a 9-pin D-shell male-to-male RS-232 null modem cable as defined in [Table 5-1](#).

Table 5-1. RS-232 Null Modem Cable Pinouts

Connector 1 Pins	Connector 2 Pins
2	3
3	2
5	5
Shield	Shield
The remainder of the nine pins are not used by the protection switching circuits. The pins may or may not be connected.	



Implementing Protection Switch Configurations

In a protection switching configuration, two decoders are interconnected in a master/slave relationship. Use this feature for a high-availability systems that need to be running constantly.

The PROTECTION SWITCH ports (item 23 on page 4-3) on the decoders' rear panels enable you to interconnect two decoders. Each port is a nine-pin D-shell connector, as described on page 4-34.

The Master/slave relationship

The first decoder to acquire a valid input signal becomes the master; the other decoder becomes the slave. If the master decoder experiences a fault—e.g., a loss of optical input, a loss of data lock, or a power failure—it automatically reverts to slave mode and master capabilities automatically switch over to the second decoder.

The cable connection

Use a standard 9-pin RS-232 null modem cable (with 9-pin, D-shell male-to-male connectors) to cable the PROTECTION SWITCH ports on two decoders together. Figure 5-5 defines the port pinouts for the RS-232 cable.

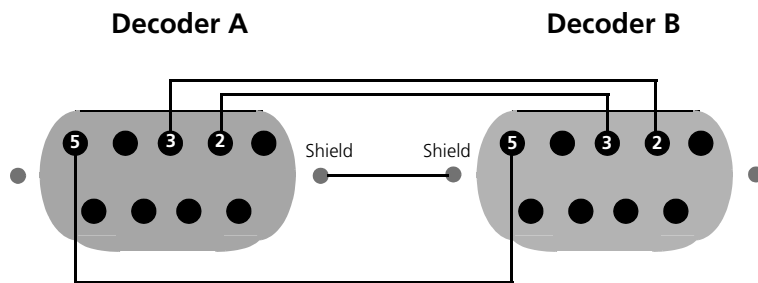

Figure 5-5. RS-232 Null Modem Cable Pinout

Note: The remainder of the nine pins are not used by the protection switching circuits. The pins may or may not be connected.

Identifying the master and the slave

In a PROTECTION SWITCH configuration, the master and slave decoders can be distinguished from one another by the state of the ONLINE LED:

- The master decoder's ONLINE LED illuminates
- The slave decoder's ONLINE LED is always off

Configuration Procedures

Protection switching is available for all DigiLink 1200/1220 systems operating in analog mode; the first procedure below describes this common configuration. Another protection switching configuration can be implemented for DigiLink 1220 systems that are operating in SDI mode; the second procedure on [page 5-11](#) describes this procedure.

To configure protection switching for a system in analog mode:

1. Connect a baseband video source input cable to the VIDEO INPUT ports of two encoders (A and B in [Figure 5-6](#) below) using a T-connector.

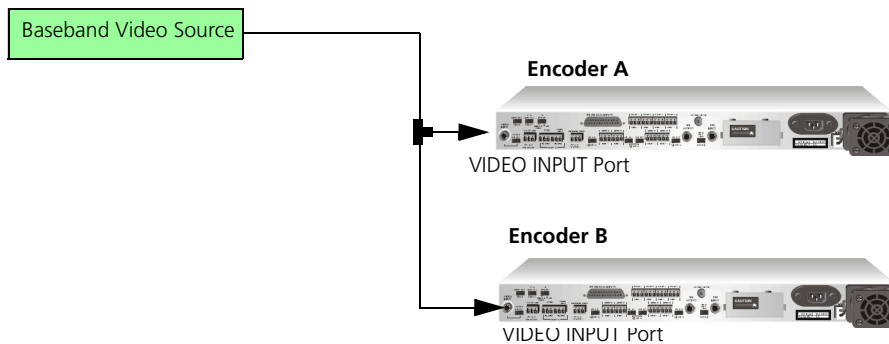

Figure 5-6. Baseband Video In Connection

Encoder B will be able to transmit an identical copy of the video transmitted by encoder A. Encoder B's output signal will be transmitted over a separate optical fiber, which can be run along a different physical path.

2. Terminate the video input cable connection to encoder B by turning the encoder's 75 OHMS switch ON. Do not terminate the video input cable to encoder A—leave that encoder's 75 OHMS switch off.



3. Connect audio inputs A ... D to the two encoders using plug connectors, as shown in [Figure 5-7](#). These connections will enable encoder B to transmit an identical copy of the audio transmitted by encoder A.

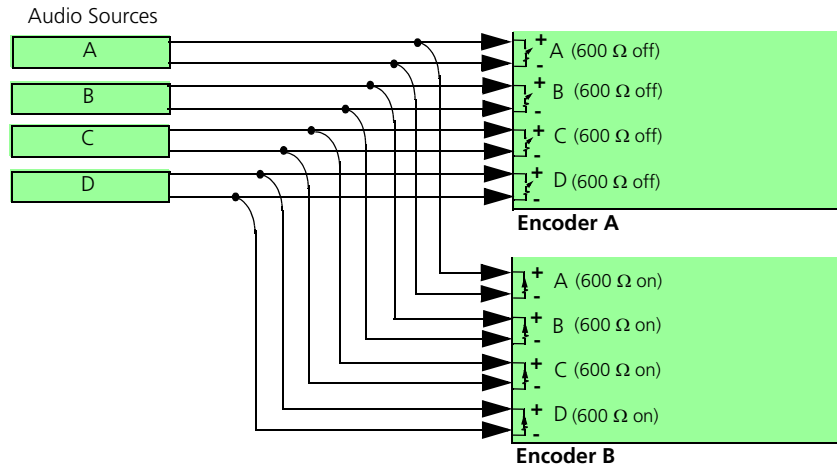

Figure 5-7. Audio In Connections

4. Terminate the audio input cable connections to encoder B by turning the encoder' 600 OHM switches on. Do not terminate the audio input cables to encoder A—leave that encoder's 600 OHMS switches off.
5. Enable only one set of decoder outputs—those belonging to the master decoder (decoder C in [Figure 5-8 on page 5-10](#)). Disable the outputs of the slave decoder (decoder D in [Figure 5-8 on page 5-10](#)).

Note: If a switch over occurs, the slave decoder outputs will become enabled automatically.

6. Install an RS-232 null modem protection cable between the PROTECTION switch ports of the two decoders.
7. Connect the audio outputs from the two decoders using plug connectors.
8. Connect the video output from the two decoders using a T-connector.

- Connect the T-connector output to the destination device.

Figure 5-8 shows the final set-up.

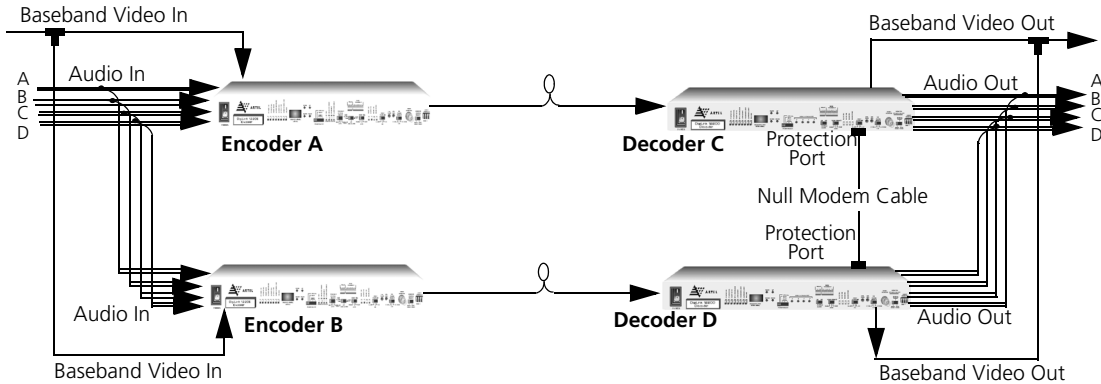

Figure 5-8. An Analog Mode Protection Switching Set-up

To verify the protection switch configuration:

Test the switch over capability by setting encoder A's AUDIBLE ALARM/LASER OFF switch to LASER OFF (see [page 3-52](#)). As a result:

- Decoder C should become the slave—its ONLINE LED should turn from on to off
- Decoder D should become the master—its ONLINE LED should illuminate and it should begin transmitting the video and audio outputs signals.
- During switch-over, the video outputs from both decoders should be monitored for uninterrupted service.

**To configure protection switching for a system in SDI mode:**

1. Connect an SDI video source input cable to the SDI INPUT ports on two encoders (encoders A and B in Figure 5-9 below).

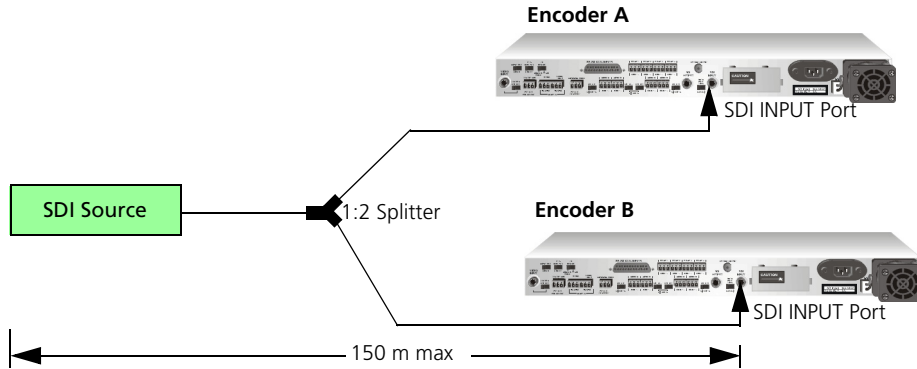
**Figure 5-9. SDI In Connection**

Note: The example in Figure 5-9 shows the SDI feed being divided by a 1:2 resistive power splitter. For this kind of an implementation, Artel recommends a model ZFRSC-2075 Mini-Circuits splitter. This splitter adds approximately 6 dB of loss, and thereby reduces the maximum cable length to 150 m. The splitter adds no measureable jitter when this 150 m maximum distance is maintained.

2. Connect two decoders (C and D) together in a manner similar to the previous analog protection switch example with one additional connection—a 75 Ω coaxial cable connection between the SDI OUTPUT port of one decoder and the SDI INPUT port of the other decoder. Figure 5-10 shows a sample cable set-up.

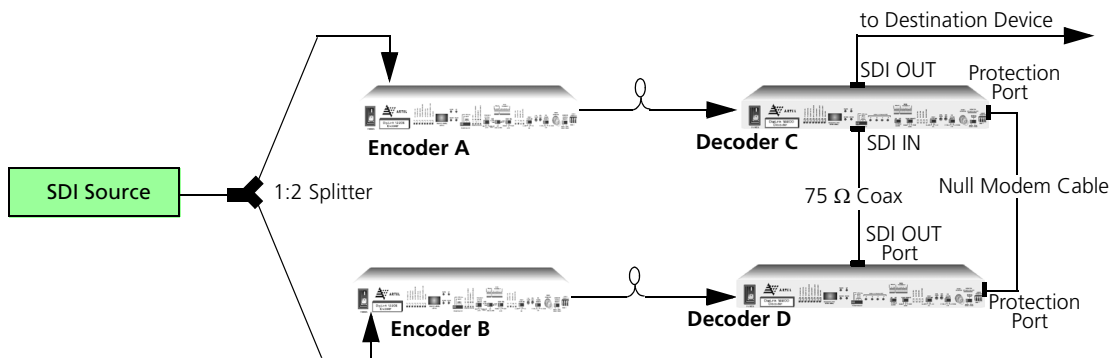
**Figure 5-10. Point-to-Point Protection Switching for SDI Signal**

- On the decoder providing the SDI electrical input connection (decoder C in [Figure 5-10](#)), use the SDI output port as the transmit port to the destination device.

Note: When both encoders are transmitting optically without problems, either decoder C or decoder D may be the master, whichever receives the SDI signal first.

If the optical transmission from encoder B fails, encoder A provides the SDI signal and decoder C becomes (or remains) the master. The ONLINE LED on decoder C turns on and the ONLINE LED on decoder D turns off. The SDI signal will flow in this way:

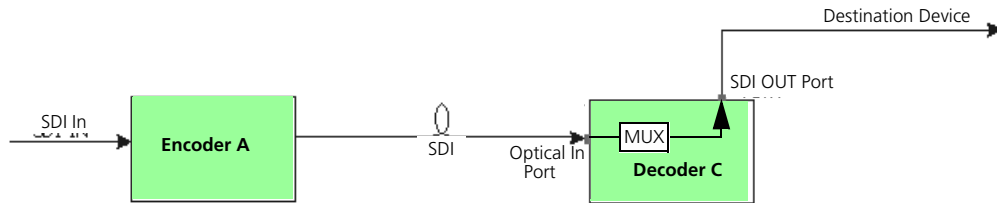

Figure 5-11. SDI Signal Flow from Encoder A to Decoder C

If encoder B recovers its optical link, decoder C remains the master and decoder D remains the slave unless a problem occurs in the transmission from encoder A.

If the optical transmission from encoder A fails, encoder B will provide the SDI signal and decoder D becomes the master. The ONLINE LED on decoder D turns on and the ONLINE LED on decoder C turns off. The SDI signal will flow in this way:

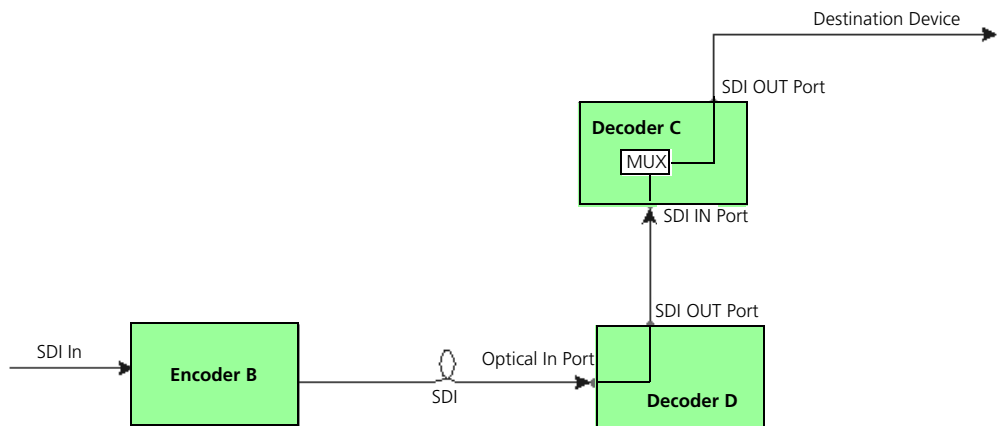

Figure 5-12. SDI Signal Flow from Encoder B to Decoder C through Decoder D



If encoder A recovers its optical link, decoder D remains the master and decoder C remains the slave unless a problem occurs in the optical transmission from encoder B.

Alternative SDI configurations

The previous examples showed how protection switching can be implemented to protect the integrity of the transmission with respect to redundant encoders as well as redundant fiber optic links. Protection switching can also be used to support redundant fiber links when only one encoder is used. The first example below shows protection switching on the decoders C and D when encoder A transmits with two lasers—a built-in 1310 or 1550 nm laser and a laser cartridge.

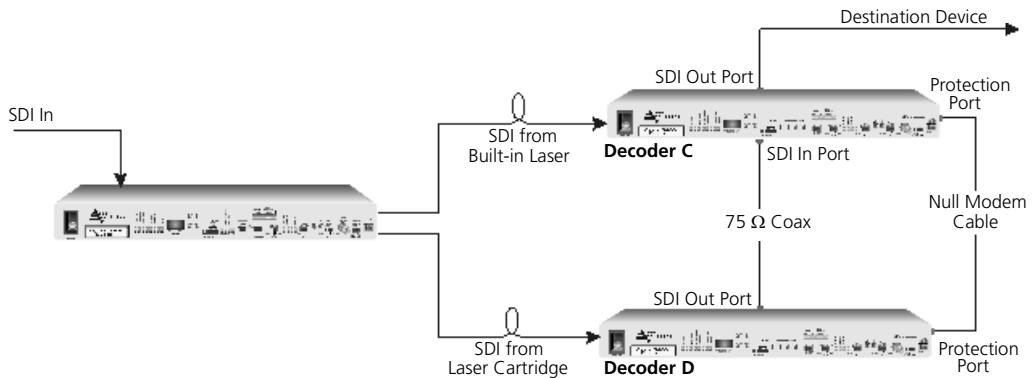

Figure 5-13. Protecting Redundant Optical Transmissions from Encoder A

The second example shows encoder A passing its optical transmission through a MegaWav MW18202C two-way splitter.

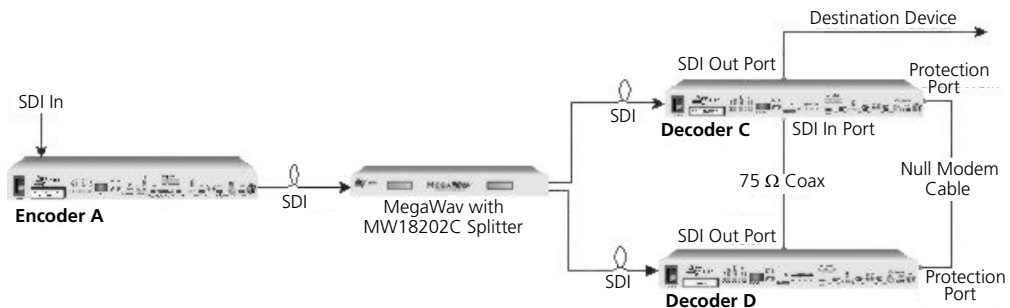

Figure 5-14. Protecting Redundant Optical Transmissions from Two-way Splitter



A

Fiber Optic Cables

This appendix provides information on fiber optic cables, and describes how to select the proper cable for your network application.

This Appendix includes the following sections:

- [Fiber Optic Cable Properties \(page A-2\)](#)
- [Fiber Optic Cables \(page A-6\)](#)
- [Selecting Fiber Optic Cable \(page A-9\)](#)

Fiber Optic Cable Properties

Bandwidth in optical fiber is limited by a phenomena known as *dispersion*. Because of dispersion, fiber bandwidth is inversely proportional to fiber length. There are two types of dispersion:

- Modal dispersion (below)
- Chromatic dispersion ([page A-4](#))

In addition to dispersion information, this section includes information on:

- Modal bandwidth ([page A-4](#))
- Signal attenuation ([page A-5](#))

Modal dispersion

Modal dispersion is the spreading of light over time as it travels through the fiber. Dispersion is the main mechanism that limits the bandwidth or information-carrying capacity of a fiber. Dispersion limits fiber bandwidth, and therefore data rate.

Some of the light transmitted over a multimode fiber enters the core at a non-zero angle with respect to the axis of the fiber. The light rays repetitively reflect off the core and cladding boundary traveling in a zig-zag pattern along the length of the fiber.

The path length for the light rays (also called modes) is longer than the path length of a light ray traveling along the axis of the fiber. The longer path results in different propagation delays for components of a single light pulse. This phenomena is referred to as modal dispersion.

Note: Modal dispersion is not present in single-mode fiber.



Figure A-1 illustrates modal dispersion in optical fibers.

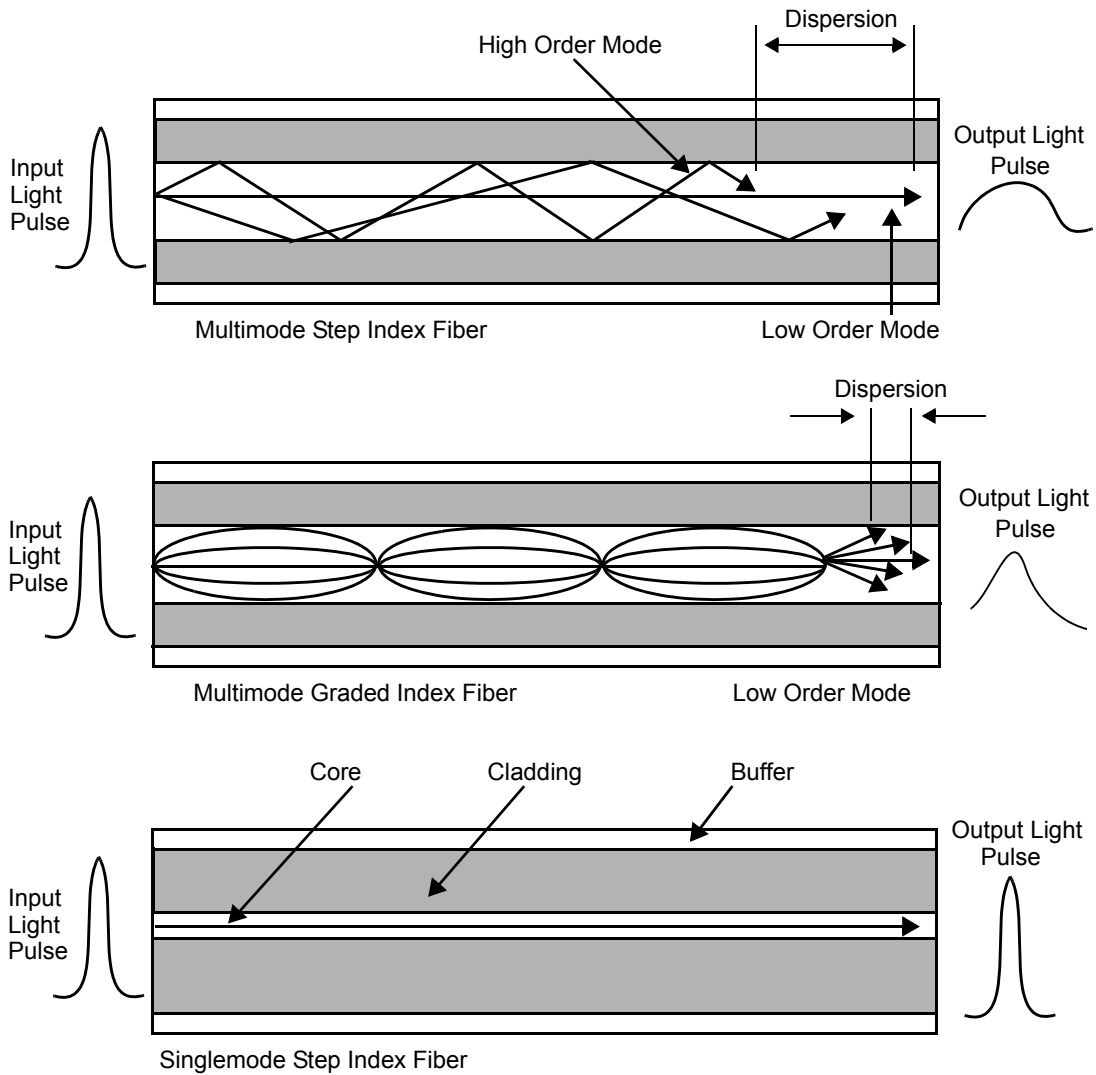

Figure A-1. Modal Dispersion in Optical Fibers

Chromatic dispersion

Chromatic dispersion occurs when optical energy is spread over a range of wavelengths (colors). Different wavelengths traveling the same path have different propagation velocities, which causes pulse spreading.

The propagation delay through the fiber core material is also a function of the light wavelength. The optical energy from LEDs and laser diodes tends to be distributed over a range of wavelengths, therefore its color is not pure. The different colors travel through the optical fiber at different speeds. This phenomena is referred to as chromatic dispersion.

Note: You only need to calculate chromatic dispersion for spans of singlemode fiber that are greater than 50 km.

You can reduce chromatic dispersion by:

- Operating at the zero dispersion wavelength of the optical fiber (1310 nm for silica glass)
- Using a light source with a narrow spectral width, such as a 1550 nm distributed feedback (DFB) laser diode.

Modal bandwidth

In general, the total fiber bandwidth is a function of both the modal and the chromatic bandwidth of the fiber. The chromatic bandwidth of an optical fiber is dependent upon the center wavelength and the spectral width of the emitting light source, as well as the material dispersion of the fiber (which is a function of wavelength).

Multimode fiber bandwidth is commonly rated in megahertz-kilometers (MHz-km). This rating refers only to the modal bandwidth (that is, the band limitations imposed by modal dispersion), and has been normalized to a 1 km length.

Note: Because all DigiLink optical transmitters are laser diodes with relatively narrow line widths, only the modal bandwidth of multimode fibers needs to be calculated.



Signal attenuation

Unlike attenuation in copper cables, signal attenuation in an optical fiber does *not* increase with increasing modulation frequency. Rather, signal attenuation in an optical fiber is *constant* across the usable frequency range of the fiber.

Optical fiber signal attenuation is proportional to fiber length and depends on the wavelength (color) of the light being propagated.

In silica glass fibers, the dominant attenuation mechanism is Rayleigh scattering, which decreases gradually with increasing wavelength.

Attenuation rises dramatically above 1550 nm due to infrared absorption.

Fiber Optic Cables

An optical fiber consists of two concentric cylindrical glass regions. The inner region (the core) has a refractive index higher than the outer region (the cladding). As a result, light injected into the core at an angle within a cone-shaped zone (the numerical aperture) is totally reflected whenever it encounters the core and cladding boundary.

The light continues to be reflected down the length of the fiber by this total internal reflection. The cladding is usually surrounded by a third layer (the buffer), which protects the optical properties of the cladding and core. One or more buffered fibers are surrounded with various strength members and jacketing to form a fiber optic cable.

Fibers are usually classified by their refractive index profiles, core size, and numerical aperture. There are three main types of fibers:

- Step-index multimode fibers
- Graded-index multimode fibers
- Singlemode fibers

Step-Index multimode fiber cable

Step-index multimode fibers have core diameters in the 50 ... 1000 μm range. This large core size supports many modes of light propagation. The different paths give rise to modal dispersion.

Graded-index multimode fiber cable

Graded-index fibers have a core index of refraction profile that changes gradually. The index is highest in the center and decreases until the core and cladding boundary is reached. Unlike step-index fibers, light is refracted as it traverses the index gradient, continually bending back towards the center.

Because light travels faster in glass with a lower refractive index, the light farther from the center axis travels faster. The rays following the longest paths have a faster average velocity, so that all modes tend to arrive at any point at nearly the same time. This reduces dispersion to provide a higher bandwidth fiber.



Table A-1 provides information on graded-index multimode fiber optic cable attenuation characteristics.

Table A-1. Graded-Index Multimode Fiber Optic Cable Characteristics

Fiber Geometry (core and cladding)	Fiber Grade	Maximum Attenuation (dB/km)		Typical Attenuation (dB/km)		Modal Bandwidth (MHz/km)	
		1310 nm	1550 nm	1310 nm	1550 nm	Min	Max
50/125 μm	Standard	1.5	1.0	1.0	0.5	400	800
	High	0.9	0.6	0.7	0.4	600	1200
	Premium	0.7	0.4	0.5	0.3	800	2000
62.5/125 μm	Standard	2.0	1.0	1.2	0.6	150	300
	High	1.0	0.7	0.8	0.5	400	800
	Premium	0.8	0.5	0.6	0.4	500	1000

Note: Ensure that any fiber cable longer than 4 km is singlemode fiber optic cable. Singlemode fiber cable has higher bandwidth and lower loss properties than multimode fiber cable.

Singlemode Fibers

Singlemode fibers offer a method of limiting modal dispersion. These fibers have a core diameter small enough to allow only one mode to propagate. With dispersions of only tens of picoseconds/km, the fibers have exceptional bandwidths and low losses that make them suited to long distance, high speed telecommunications, and CATV.

Singlemode fiber small core size makes them more difficult to splice. They generally require a laser light source to couple a sufficient amount of light into the small fiber core.

Table A-2 provides information on step-index singlemode fiber optic cable characteristics.

Table A-2. Step-Index Singlemode Fiber Optic Cable Characteristics

Fiber Geometry (core and cladding)	Fiber Grade	Maximum Attenuation (dB/km)		Typical Attenuation (dB/km)		Modal Bandwidth (MHz/km)	
		1310 nm	1550 nm	1310 nm	1550 nm	Min	Max
9/125 μm	Standard	1.0	0.6	0.7	0.4	400	800
	High	0.7	0.5	0.5	0.3	600	1200
	Premium	0.5	0.25	0.4	0.2	800	2000

Note: Ensure that any fiber cable longer than 4 km is singlemode fiber optic cable. Singlemode fiber cable has higher bandwidth and lower loss properties than multimode fiber cable.



Selecting Fiber Optic Cable

Two optical wavelengths have become standards for long distance high speed data transmission:

- 1310 nm—Provides the maximum data bandwidth due to the zero chromatic dispersion property of silica glass fibers at this wavelength.
- 1550 nm—Provides the lowest possible attenuation, which permits data transmission over the longest distance without repeaters.

For lower equipment cost and easier cable splicing, use multimode fiber for cable lengths under 4.4 km (2.7 mi). To support reliable transmission of the DigiLink digital data stream, ensure that the optical bandwidth and attenuation of the fiber is sufficient for DigiLink operation.

When purchasing fiber optic cable, the most important considerations are the following fiber transmission specifications:

- Maximum attenuation
- Minimum bandwidth
- Diameter of the fiber core and cladding

Secondary considerations in choosing fiber optic cable include:

- Rated pull strength
- Cable constructions
- Number of fibers packaged in a cable

Refer to your cable manufacturer's specifications for information regarding these cable characteristics.

Using Fiber Optic Cable

To ensure proper operation of the fiber optical cables, follow the precautions listed below.

- Do not exceed the -25 dB maximum optical return loss in the optical fiber plant.
- When no fiber cable is connected, install the protective plastic cap.

-
- Before you connect fiber cable to equipment, ensure that you clean the fiber carefully (use an alcohol wipe and an oil-free canned air blast).
 - Ensure that no dirt particles or other contamination is introduced into the optical connector. Failure to keep the optical connector free of contaminants may result in severely reduced optical output power and reduced range.
If a dirt particle becomes imbedded in the optical connector, return the unit to Artel. Refer to [page xxiii](#) for instructions on returning equipment for service.



B

Installing a Laser Cartridge

Appendix B

Appendix C provides instructions for installing a laser cartridge into the DigiLink encoder rear panel.

This Appendix includes the following sections:

- [Laser Cartridge Overview \(page B-2\)](#)
- [Installing a Laser Cartridge \(page B-4\)](#)
- [Removing a Laser Cartridge \(page B-7\)](#)

Laser Cartridge Overview

To provide you with configuration flexibility, the DigiLink encoders are designed to accept an optional laser cartridge. By installing a laser cartridge, you can:

- Add an optical capability to an encoder that does not have a built-in laser (the DL1200EN/EPN and DL1220EN/EPN models)
- Increase the transmission distance as required
- Customize encoder wavelengths
- Configure up to 16 separate DigiLinks with an Artel MegaWav Dense Wavelength Division Multiplexer (DWDM), enabling you to transmit up to 16 multiplexed signals over a single fiber

Table B-1 lists the Artel laser cartridge model numbers with their ITU standard wavelength equivalents and the corresponding channel numbers.

Table B-1. Laser Cartridge Models and ITU Wavelengths

Model Number	Wavelength (nm)	ITU Channel Number
WL13	1310 (\pm 30)	
WL15	1550 (\pm 35)	
WL51	1536.61	51
WL49	1538.19	49
WL47	1539.77	47
WL45	1541.35	45
WL43	1542.94	43
WL41	1544.52	41
WL39	1546.12	39
WL37	1547.71	37
WL35	1549.31	35
WL33	1550.92	33



Model Number	Wavelength (nm)	ITU Channel Number
WL31	1552.52	31
WL29	1554.13	29
WL27	1555.74	27
WL25	1557.36	25
WL23	1558.98	23
WL21	1560.61	21

Along with the standard 1310 nm and 1550 nm lasers are 16 are notched lasers. These notched lasers have narrow optical bandwidths and are used in DWDM applications.

Identifying the Wavelength in an Installed Laser Cartridge

When you are using a laser cartridge, there are two ways to identify the wavelength of the installed laser:

- By the label on the optical port of the laser cartridge (see column 3 in [Table B-1](#)); this label corresponds to the ITU channel grid for notched lasers
- By using the METER SELECT switch and the AUDIO level display window on the encoder's front panel (see [page 3-50](#) for details)

Installing a Laser Cartridge

Installing a laser cartridge into the DigiLink encoder does not require any tools and can be accomplished with the encoder under power.

To install a laser cartridge:

1. Locate the laser cartridge slot on the rear of the encoder, as shown in [Figure B-1](#).

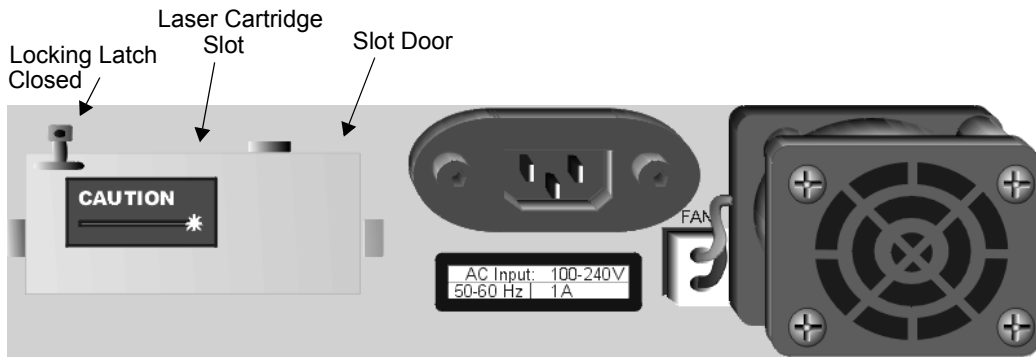

Figure B-1. Laser Cartridge Slot on the Encoder Rear Panel

2. Swivel the locking latch 90° clockwise to the open position.
3. Place the top of the card edge on the laser cartridge against the top of the slot with the cartridge body angled downward toward the slot door, as shown in [Figure B-2](#).

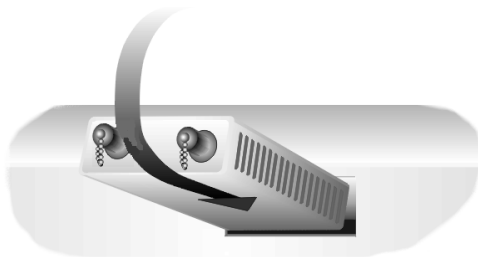

Figure B-2. Installing a Laser Cartridge



4. As you slide the laser cartridge into the slot, rotate it until the card edge is aligned with the slot opening. The slot door is hinged at the top, and this rotating motion allows the cartridge to open the slot door as it is being inserted.
5. Push in the laser cartridge until the card edge is seated firmly into the encoder card edge connector.
6. Swivel the locking latch back to the closed position.

Using the Optical Connector on a Laser Cartridge

When you install a laser cartridge in an encoder that has a built-in 1310 nm or 1550 nm encoder, you now have access to two optical output connections.

- To use the output produced by a built-in laser, connect a fiber cable to the OPTICAL OUTPUT port on the rear panel of the encoder (described on [page 3-36](#))
- To use the output produced by the installed laser cartridge, connect a fiber cable to the Optical Output port on the face of the cartridge

Both optical paths are valid. You may use one or both optical ports to transmit the encoder's digital output.

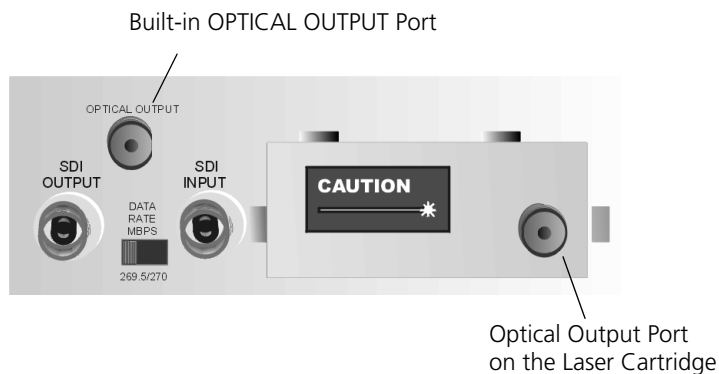

Figure B-3. Optical Ports with a Laser Cartridge Installed

The DL1200EN/EPN and DL1220EN/EPN encoder models do not have a built-in laser or an OPTICAL OUTPUT port enabled on the rear panel. When a laser cartridge is installed, the Optical Output port on the cartridge provides a single optical output connection.

Using a Laser Cartridge at Encoder Startup

The laser cartridge's laser transmitter is designed with a thermo-electric cooler that controls laser heating and cooling. When you power up the encoder, it disables laser output (approximately 10 s) until the laser reaches proper operating temperature. This feature prevents undesired wavelengths from being transmitted into a network.

Note: During this 10 s period, the LASER DEGRADE and LASER FAIL LEDs will illuminate. Ignore these indicators during the short warm-up period



Removing a Laser Cartridge

To remove a laser cartridge:

1. Replace the Optical Output connector cover.
2. Grasp the connector cover firmly and pull out the laser cartridge from the slot.

Note: The laser cartridge may be difficult to remove from the unit due to the exact tolerances of the laser cartridge slot in the chassis.



Index

Numerics

- 48 VDC input connector
 - for the decoder 4-5
 - on the encoder 3-5
- 600 OHMS switch
 - on the encoder 3-25
- 75 OHMS switch
 - on the encoder 3-17

A

- AC couple setting
 - for the decoder 4-25
 - for the encoder 3-22
- AC power cord
 - for the decoder 4-5
 - for the encoder 3-5
- alarm
 - audible
 - on the encoder 3-52
- alarm mode
 - changing 4-11
- ALARM RELAY connector
 - on the decoder 4-31
- ALARM relay connector
 - on the encoder 3-53
- analog and digital switch bridging 5-4
- analog operating mode 1-3
- ANALOG VIDEO LED
 - on the encoder 3-47
- Artel customer service
 - contacting 2-xxiii
- AUDIBLE ALARM switch
 - on the decoder 4-44
- AUDIBLE ALARM/LASER OFF switch

- on the encoder 3-52
- audio connections
 - for the encoder
 - using multi-pair cable 3-24
- audio framing error 4-38
- AUDIO GAIN ADJUST potentiometers
 - on the decoder 4-27
- audio impedance
 - for the encoder 3-26
- AUDIO INPUTS connector
 - on the encoder 3-23
- AUDIO LEVEL display
 - on the encoder 3-50
- AUDIO MONITOR connector
 - on the encoder 3-42
- AUDIO MONITOR port
 - on the decoder 4-46
- AUDIO OUTPUT connector
 - on the decoder 4-26
- audio power display
 - on the decoder 4-41
- audio power level
 - display on the decoder 4-41
- AUTO ON LED
 - on the decoder 4-40
 - on the encoder 3-49
- automatic protection switching
 - an example 5-6

B

- bandwidth 1-16
 - decoder 1-18
- block diagram
 - DL1200E encoder 1-13

DL1220E encoder 1-14

C

cable equalization

for the decoder

selecting a range 4-21

selecting range 3-18

cable equalization procedure

for the decoder 4-24

for the encoder 3-21

Canadian Emissions Requirements 1-vi

CARRIER LOST LED

on the decoder 4-38

Cautions 1-v

character cursor

on the decoder

for the Test Screen editor 4-57

on the encoder

for the Test Screen editor 3-60

CLAMP setting

for the decoder 4-25

for the encoder 3-22

configuration

decoder quick start 2-2

encoder quick start 2-7

configuration quick start

encoder 2-7, 2-8, 2-9, 2-10, 2-11,
2-12

configurations

analog and digital switch bridging 5-4

automatic protection switching 5-6

critical applications 5-6

dual services switched network 5-5

point-to-point communication 5-2

connecting a DC power cord

to a decoder 4-5

connecting an AC power cord

to a decoder 4-5

connectors

on the decoder

ALARM RELAY 4-31

AUDIO MONITOR port 4-46

AUDIO OUTPUT port 4-26

OPTICAL INPUT port 4-14

PROTECTION SWITCH port 4-34

RELAY output 4-30

REMOTE VIDEO SELECT 4-18

RS-232 DATA OUTPUTS port 4-29

SDI INPUT port 4-15

SDI OUTPUT port 4-33

VIDEO MONITOR port 4-44

VIDEO OUTPUT port 4-20

on the encoder

ALARM relays 3-53

AUDIO INPUTS 3-23

AUDIO MONITOR 3-42

OPTICAL OUTPUT port 3-36

RELAY inputs 3-28

REMOTE TX SELECT 3-12

REMOTE VIDEO SELECT 3-35

RS-232 DATA INPUTS port 3-26

SDI INPUT port 3-29

SDI OUTPUT port 3-38

VIDEO INPUT port 3-16

VIDEO MONITOR port 3-40

protection switch 5-7

contact closures

on the encoder

for major alarms 3-53

for minor alarms 3-53

Contacting

customer service 2-xxiii

cooling requirements 2-4

critical applications 5-6

crosstalk

minimizing in a decoder 4-26

minimizing in an encoder 3-24

Customer service

contacting 2-xxiii

D

- DATA CHANNEL LEDs
 - on the decoder 4-39
 - on the encoder 3-48
- DATA RATE MBPS switch
 - on the encoder 3-34
- DC couple setting
 - for the decoder 4-25
 - for the encoder 3-23
- DC power cord
 - for the decoder 4-5
 - for the encoder 3-5
- DC power supply
 - safety precaution 3-5, 4-5
 - terminal block
 - on the decoder 4-6
 - on the encoder 3-6
- Declaration of Conformity 1-vii
- decoder
 - bandwidth 1-18
 - functional description 1-17
- DigiLink
 - architecture 1-2
 - bandwidth 1-16
 - installing 2-4
 - laser cartridge 1-7
 - model numbers 1-9, 1-11, 1-12
 - product overview 1-2
 - transmission distances 1-6
 - unpacking 2-3
- displaying laser type
 - on the encoder 3-51
- displaying temperature
 - on the encoder 3-51
- displaying the audio power level
 - on the encoder 3-50
- displays
 - on the decoder
 - RECEIVER LIGHT LEVEL 4-40
- DOWN button

- on the decoder
 - for the Test Screen editor 4-47
- on the encoder
 - for the Test Screen editor 3-54, 3-56
- dual services switched network 5-5

E

- EDH Mode 1-4
 - EDH mode 4-52
 - electrical transport
 - functional description 1-6
 - encoder
 - bandwidth 1-16
 - block diagram 1-13, 1-14
 - functional description 1-13
 - ENTER button
 - on the decoder
 - for the Test Screen editor 4-47, 4-49
 - on the encoder
 - for the Test Screen editor 3-54, 3-56
 - EQUALIZATION ADJUSTMENT
 - potentiometer
 - on the decoder 4-22
 - EQUALIZATION RANGE SELECT switch
 - on the decoder 4-21
 - on the encoder 3-18
 - Error Detection Handling 1-4
- F**
- FC-PC connector on the encoder's OPTICAL OUTPUT port 3-37
 - FC-PC optical connector
 - on the decoder 4-14
 - Federal Communications Commissions Notice 1-vi
 - FRAMING LOST LED
 - on the decoder 4-37

Front panel button
on the decoder
DOWN 4-49

front panel button
on the decoder
ENTER 4-49
PGRM 4-49
UP 4-49

front panel buttons
on the encoder 3-54

functional description
decoder 1-17
encoder 1-13

G

ground loops
eliminating in a decoder 4-26
eliminating in an encoder 3-24

H

Help menu 4-61
on the encoder
for the Test Screen editor 3-65

I

incrementing line numbers
on the decoder
for the Test Screen editor 4-57

INPUT SELECT switch
on the decoder 4-10

installation
considerations 2-5

internal audible alarm
for the encoder 3-52
on the decoder 4-44

International EMC Requirements 1-vi
CISPR 22 1-vi
EN50 082-1 1-vi
EN55 022 1-vi
IEC 801-2 1-vi

IEC 801-3 1-vi
IEC 801-4 1-vi

IRE sync pulse
for the decoder 4-25
for the encoder 3-23

L

Laser cartridge
startup B-6
laser cartridge 1-7
identifying the laser wavelength B-3
in the encoder
optical connector 3-37
power-up considerations 3-7

laser cartridges
in the encoder 3-37

LASER DEGRADE LED
on the encoder 3-45

LASER DISABLE LED
on the encoder 3-47

LASER FAIL LED
on the encoder 3-45

LASER OFF switch
on the encoder 3-52

laser type display
on the encoder 3-51

LEDs
on the decoder 4-36
AUTO ON 4-40
CARRIER LOST 4-38
DATA CHANNEL 1 ... 8 4-39
FRAMING LOST 4-37
LOW LIGHT 4-37
MAIN ON 4-40
MAIN SYNC 4-40
ONLINE 4-38
OPTICAL OVERLOAD 4-37
POWER FAIL 4-37
POWER ON 4-37
RELAY 1 ... RELAY 4 4-39

- TEMP HIGH 4-37
- TEST ON 4-40
- on the encoder 3-44
 - ANALOG VIDEO 3-47
 - AUTO ON 3-49
 - DATA CHANNEL 1 ... DATA CHANNEL 8 3-48
 - LASER DEGRADE 3-45
 - LASER DISABLE 3-47
 - LASER FAIL 3-45
 - LOCK LOST 3-45
 - MAIN ON 3-49
 - MAIN SYNC 3-49
 - ONLINE 3-46
 - POWER FAIL 3-45
 - POWER ON 3-45
 - RELAY 1 ... RELAY 4 3-48
 - SDI 3-47
 - STANDBY 3-47
 - TEMP HIGH 3-45
 - TEST ON 3-49
 - VIDEO OVERLOAD 3-46
 - troubleshooting the decoder 4-38
 - troubleshooting the encoder 3-45, 3-46
- LOCK LOST LED
 - on the encoder 3-45
- LOW LIGHT LED
 - on the decoder 4-37
- M**
- Main menu
 - on the decoder
 - for the Test Screen editor 4-51
 - on the encoder
 - for the Test Screen editor 3-58
- MAIN ON LED
 - on the decoder 4-40
 - on the encoder 3-49
- MAIN SYNC LED
 - on the decoder 4-40
 - on the encoder 3-49
- maintenance
 - routine 3-52
- MegaLink 1290X transceiver 5-4
- METER SELECT switch
 - on the decoder 4-40
 - on the encoder 3-50
- modes of operation
 - analog 1-3, 1-4
 - EDH 1-3
 - SDI 1-3, 1-4
- MONITOR SOURCE SELECT switch
 - on the decoder 4-45
 - on the encoder 3-41
- multi-burst video test pattern 3-20
- multiburst video test pattern 4-23
- N**
- NTSC default test pattern 4-48
 - for the encoder 3-55
- NTSC test patterns 4-60
 - on the encoder 3-63
- O**
- ONLINE LED
 - on the decoder 4-38
 - on the encoder 3-46
- operating mode
 - on the encoder
 - selecting 3-9
- OPTICAL INPUT port
 - on the decoder 4-14
- optical input power display
 - on the decoder 4-41
- OPTICAL OUTPUT port
 - on the encoder 3-36
- OPTICAL OVERLOAD LED
 - on the decoder 4-37
- optical power level display

- on the decoder 4-41
- optical radiation
 - cautions 1-v
 - warnings 1-v
- optical transport
 - functional description 1-6

P

- PAL default test pattern 4-48
- PAL test patterns 4-60
 - on the encoder 3-63
- PGRM button
 - on the decoder 4-49
 - for the Test Screen editor 4-47
 - on the encoder
 - for the Test Screen editor 3-54, 3-56
- point-to-point encoder-decoder
 - configuration 5-2
- potentiometers
 - on the decoder
 - AUDIO GAIN ADJUST 4-27
 - EQUALIZATION ADJUSTMENT 4-22
 - VIDEO GAIN 4-22
 - on the encoder
 - EQUALIZATION ADJUSTMENT 3-19
 - VIDEO GAIN 3-19
- POWER FAIL LED
 - on the decoder 4-37
 - on the encoder 3-45
- POWER ON LED
 - on the decoder 4-37
 - on the encoder 3-45
- power supply fan 2-4
- POWER switch
 - on the decoder 4-7
 - on the encoder 3-7
- power up
 - decoder 4-7
 - encoder 3-7

- product
 - damaged 2-xxiii
 - overview 1-2
- PROTECTION SWITCH port
 - on the decoder 4-34
- protection switching
 - verifying the configuration 5-10

R

- RA
 - See return authorization number 2-xxiii
- re-cabling an encoder 3-52
- RECEIVER LIGHT LEVEL display
 - decoder 4-40
- Regulatory Compliance 1-vi, 1-vii
- RELAY input connectors
 - on the encoder 3-28
- RELAY LEDs
 - on the decoder 4-39
 - on the encoder 3-48
- RELAY output connector
 - on the decoder 4-30
- REMOTE TX SELECT connector
 - on the encoder 3-12
- REMOTE VIDEO SELECT connector
 - on the decoder 4-18
 - on the encoder 3-35
- Return authorization number 2-xxiii
- RS-232 DATA INPUTS connector
 - on the encoder 3-26
 - data transmission rates 3-27
 - pinouts 3-27
- RS-232 DATA OUTPUTS port
 - on the decoder 4-29
 - data transmission rates 4-30
 - pinouts 4-29
- RS-232 null modem cable
 - for protection switching 5-6
 - pinouts 5-6

S

safety extra low voltage
 output source 4-6
 for the encoder 3-6

SCRAMBLE switch
 on the decoder 4-33
 on the encoder 3-29

SDI INPUT connector
 on the encoder 3-29

SDI INPUT port
 on the decoder 4-15

SDI LED
 on the encoder 3-47

SDI operating mode 1-4, 3-15, 3-29

SDI OUTPUT port
 on the decoder 4-33
 on the encoder 3-38

SELV output source 4-6
 for the encoder 3-6

shielded twisted pair cable
 for audio inputs to the encoder 3-24
 for audio outputs from the decoder
 4-26

shipment
 contents 2-3
 damaged 2-xxiii

single-mode optical fiber 3-36

site requirements 2-2

SMPTE 259M-C 3-15, 3-29

standards
 ANSI TI.502-1988 3-15
 ITU 601 1-4, 3-15
 SMPTE 259M 1-4, 1-11
 SMPTE 259M-C 3-15, 3-29

STANDBY LED
 on the encoder 3-47

startup
 laser cartridge B-6

switched network topology 5-5

switches

on the decoder
 AUDIBLE ALARM 4-44
 EQUALIZATION RANGE SELECT
 4-21
 INPUT SELECT 4-10
 METER SELECT 4-40
 MONITOR SOURCE SELECT 4-45
 POWER 4-7
 SCRAMBLE 4-33
 VIDEO COUPLING 4-24
 VIDEO SELECT 4-17
 VIDEO SQUELCH 4-19

on the encoder
 600 OHMS 3-25
 75 OHMS 3-17
 AUDIBLE ALARM/LASER OFF 3-52
 DATA RATE MBPS 3-34
 EQUALIZATION RANGE SELECT
 3-18
 METER SELECT 3-50
 MONITOR SOURCE SELECT 3-41
 POWER 3-7
 SCRAMBLE 3-29
 TRANSMIT SOURCE SELECT 3-9
 TX DEFAULT 3-11
 VIDEO COUPLING 3-22
 VIDEO SELECT 3-32

T

TEMP HIGH LED
 on the decoders 4-37
 on the encoder 3-45

temperature display
 on the decoder 4-41
 on the encoder 3-51

terminating video input
 to the encoder 3-17

TEST ON LED
 on the decoder 4-40
 on the encoder 3-49

- test pattern
 - NTSC 4-60
 - on the encoder
 - NTSC 3-63
 - Test Screen editor
 - menu flowchart 3-57
 - on the decoder
 - front panel buttons 4-47
 - Test Patterns menu 4-60
 - timeout 4-48
 - on the encoder
 - front panel buttons 3-54
 - Test Patterns menu 3-63
 - timeout 3-55
 - Text Entry menu
 - on the decoder
 - for the Test Screen editor 4-56
 - on the encoder
 - for the Test Screen editor 3-59
 - Text Entry menu cursors
 - on the decoder
 - for the Test Screen editor 4-57
 - on the encoder 3-60
 - for the Test Screen editor 3-60
 - Text line
 - incrementing line numbers
 - on the encoder 3-61
 - saving in the Test Screen editor 3-62
 - tools and equipment
 - for installation 2-3
 - transmission
 - distances 1-6
 - transmission rate
 - for the encoder 3-34
 - TRANSMIT SOURCE SELECT switch
 - on the encoder
 - setting 3-9
 - with REMOTE TX SELECT connector 3-10
 - with the TX DEFAULT switch 3-10
 - transport mechanisms
 - electrical 1-6
 - optical 1-6
 - TX DEFAULT switch
 - on the encoder 3-11
- U**
- UP button
 - on the decoder
 - for the Test Screen editor 4-47
 - on the encoder
 - for the Test Screen editor 3-54, 3-56
 - Up button
 - on the decoder 4-49
 - user interface
 - Main menu
 - on the decoder 4-51
 - on the encoder 3-58
 - Text Entry menu
 - on the encoder
 - for the Test Screen editor 3-59
 - Utah scientific
 - UTAH-300 routing system 5-3
- V**
- ventilation 2-4
 - VIDEO COUPLING switch
 - on the decoder 4-20, 4-24
 - on the encoder 3-17, 3-22
 - VIDEO GAIN potentiometer
 - on the decoder 4-22
 - on the encoder 3-19
 - video input
 - channel operation 1-15
 - VIDEO INPUT port
 - on the encoder 3-16
 - cable equalization range 3-18
 - VIDEO MONITOR port
 - on the decoder 4-44

- on the encoder 3-40
- VIDEO OUTPUT port
 - on the decoder 4-20
- VIDEO OVERLOAD LED
 - on the encoder 3-46
- VIDEO SELECT switch
 - on the decoder 4-17
 - on the encoder 3-32
- video signal
 - clipping 3-16
- video source impedance 3-17
 - for the encoder 3-26
- VIDEO SQUELCH switch
 - on the decoder 4-19
- voltage rating
 - for relay contacts
 - on the encoder 3-53

W

- Warnings 1-v
- wire clamp connectors 2-3

