



ARTEL

A Division of Newfound Technology



DV6000™

DV270SDI/DV270SDIT/DV270SDIR Equipment Manual

1500902 Revision A

Access & Transport

DV6000[®]

DV270SDI/DV270SDIT/DV270SDIR Equipment Manual

1500902 Revision A

DV270SDI/DV270SDIT/DV270SDIR Equipment Manual

Artel Document Number: 1500902 Rev A

Copyright © 2006 Artel Incorporated. All rights reserved.

Trademarks

DV6000 and the Artel logo are registered trademarks of Newfound Technology. Copyright © 2006 Newfound Technology. All Rights reserved. All other brand and product names are trademarks or registered trademarks of their respective companies.

Contents and specifications within this manual are subject to change without notice.

Revision History

Revision	Date	Reason for Change
A	1/23/06	Initial release.

Contacting Artel

Contact Information

You can contact Artel by phone, e-mail, Internet, fax, or mail. When contacting Artel Technical Support, please be prepared to provide the information listed below:

- Your company name and address
- Your phone and fax number
- Your e-mail address
- The system location
- A description of the problem(s) you are experiencing
- Any equipment part/model numbers related to your specific problem(s)
- The best way to contact you (phone, fax, e-mail, or mail)
- The best time to contact you

Phone

Call Artel 24 hours a day, 7 days a week: **978.263.5775 and Press 1 for Technical Support.**

E-Mail

Send an e-mail, including all the information listed in Contact Information (above):
technical@artel.com

Internet

Visit us on the World Wide Web at:
<http://www.artel.com>

Fax

Send a fax with a cover sheet including all the information listed in
Contact Information (above): 978.263.9775

Mail

Send your letter, including the information listed in Contact Information:

Attn: Customer Support
Artel Video Systems
A Division of Newfound Technology
330 Codman Hill Road
Boxborough, MA 01719

Repair Services

Contact Sales to request a Return Material Authorization (RMA) if you need to return a product for repair.

<http://www.artel.com> (Customer Support > RMA Request Form)

Technical Training

Contact Sales for inquiries concerning Product Training. Please be prepared to provide a list of products on which you would like training.

978.263.5775 X225 or customer care@artel.com

Providing Feedback on this Publication

Artel welcomes your suggestions and assistance in identifying any errors, inaccuracies, or misleading information. Please contact our Technical Publications Department with an e-mail referencing the document number and page number(s) to which the feedback applies.

Send your e-mail to:
technical@artel.com

Table of Contents

Chapter 1	Introduction	1-1
	Overview	1-1
	Document Conventions	1-2
	General Safety Compliance	1-2
	Statement of Compliance	1-2
	Certification	1-3
	Related Publications	1-5
	Tools and Materials	1-6
	Acronyms and Abbreviations	1-6
Chapter 2	DV270SDI Modules	2-1
	Overview	2-1
	SPFs	2-1
	Applications	2-2
	Network Management	2-4
	DV6400 Craft Software	2-4
	DV6000 DAP2 and DV6300/DVFE Configuration Tools	2-4
	IMI 9000 Monitoring Interface Software	2-4
	Part Numbers	2-4
Chapter 3	DV270SDIT Transmitter Module	3-1
	Overview	3-1
	Physical Description	3-2
	Front Panel	3-2
	Rear Panel	3-4
	DV270SDIT Transmitter Board Configuration	3-4
	Functional Description	3-6
	Module Control and Alarms	3-8
	DV270SDIT Transmitter Parameters - Decoder (Right Slot)	3-8
	DV270SDIT Transmitter - CPU Alarm Status (Left Slot)	3-9
	Controls	3-10
	Part Numbers	3-10
Chapter 4	DV270SDIR Receiver Module	4-1
	Overview	4-1
	Physical Description	4-2
	Rear Panel	4-4
	Functional Description	4-6
	Module Control and Alarms	4-8
	DV270SDIR Receiver Parameters - Encoder (Right Slot)	4-8
	DV270SDIR Receiver CPU Alarm Status (Left Slot)	4-9
	Controls	4-10
	Part Numbers	4-10

Chapter 5	DV270SDI Modules Installation and Checkout	5-1
	Introduction	5-1
	Installation and Checkout Procedures	5-2
	Unpacking Equipment and Inspecting for Damage	5-3
	Installing DV270SDI Modules in a DV Shelf	5-4
	Optical and Electrical Connections	5-9
	Connecting Alarm Relay Contacts	5-14
	Verifying DV270SDI Module LED Indicators	5-16
	DV270SDI Module Configuration	5-21
Chapter 6	DV270SDI Module Troubleshooting Guide	6-1
	Introduction	6-1
	Fault Analysis Tables	6-1
	Common	6-2
	DV270SDIT Transmitter Related Faults	6-3
	DV270SDIR Receiver Related Faults	6-5
Chapter 7	DV270SDI Module Maintenance	7-1
	Hardware Related	7-1
	SFP Replacement	7-1
	Defective Fan Assembly	7-6
	Firmware Related	7-7
	Firmware Upgrades	7-7
Appendix A	DV270SDI Module Specifications	A-1
Appendix B	Warranty	B-1
Index		Index-1

Introduction

This manual provides information on Artel's DV6000 family of DV270SDI modules.

- Overview*—page 1-1
- Document Conventions*—page 1-2
- General Safety Compliance*—page 1-2
- Statement of Compliance*—page 1-2
- Certification*—page 1-3
- Related Publications*—page 1-5
- Tools and Materials*—page 1-6
- Acronyms and Abbreviations*—page 1-6

Overview

The DV270SDIT and DV270SDIR are Transmitter/Receiver card pairs for the DV6000 and DV6408 product lines which interface directly to the following standards:

- DVB-ASI MPEG transport streams, defined in annex B.3.1.1 of EN 50083-9:1997 operating at a bit rate of 270Mbit/sec.
- Standard definition serial digital video streams as referenced in SMPTE 259M-C

Once encoded, the signals can be transported along with any of the other DV signal types to matching decoders at one or more locations throughout the network.

Each module occupies two card slots in the DV6000 or DV6408 shelves.

Document Conventions

Labels printed on module faceplates are shown in a different typeface (for example, **STAT**).

This manual uses the following notes, cautions, and warnings:



CAUTION *Laser Radiation—Do not stare into beam or view directly with optical instruments. This is a Class 1 laser product.*



WARNING *Personal injury might result if instructions are not followed.*



CAUTION *Equipment damage might result if instructions are not followed.*



Note *Read for added information and reminders, including when a service interruption could occur.*



Tip *Read for helpful hints.*

General Safety Compliance

This equipment conforms to the requirements of a Class I laser product as defined in the US Department of Health and Human Services, Bureau of Radiological Health Regulation 21 CFR Subchapter J.

While Class I radiation levels are not exceeded when equipment components are handled per instructions, enough invisible infrared energy is emitted from the end of an active fiber to damage the retina of the eye. To avoid potentially dangerous laser radiation, follow the operating and servicing procedures set forth in this manual in the sequences specified. CAUTION labels on the equipment alert users to the potential for exposure to hazardous amounts of invisible radiation.

Statement of Compliance

This equipment generates, uses, and can radiate radio frequency energy and if not installed and used in accordance with the instruction manual, may cause interference to radio communications. It has been tested and found to comply with limits for a Class A digital device pursuant to Subpart B of Part 15 of FCC Rules, which are designed to provide reasonable protection against such interference when operated in a commercial environment. Operation of this equipment in a residential area is likely to cause interference to TV and radio reception in which case the user, at their own expense, will be required to take whatever measures may be required to correct the interference.

Certification

Table 1.1 Standards

Type	Country	Standard
Electromagnetic Emissions		
	US	47 CFR FCC Part 15, Class A limits
	Canada	ICES-003
	European Union	EN 55 022:1998 Class A limits VCCI-1
Electromagnetic Susceptibility		
	European Union	EN 300 386:2001 v1.3.1 EN 61 000-4-2: EN 61 000-4-3: EN 61 000-4-4: EN 61 000-4-5: EN 61 000-4-6: EN 61 000-4-11:
Safety		
		UL/CSA 60950-1 EN 60 950P:2000
NEBS		GR-1089-CORE Tests 2. ESD 3.2.1 Radiated Emission (Electric Fields) 3.2.2 Radiated Emission (Magnetic Fields) 3.2.3 Conducted Emission (Voltage) 3.2.4 Conducted Emission (Current) 3.3.1-2 Radiated Immunity (Electric Fields) 3.3.3 Conducted Immunity 4.5.4 Short Circuit Testing 4.5.10 Lightning Surge (AC Power Port) 7.0 Electrical Safety Criteria 9.0 Bonding and Grounding

continued on next page

Table 1.1 Standards (cont'd)

Type	Country	Standard
		GR-63-CORE Tests
		4.1.1.1 Low Temp and Thermal Shock
		4.1.1.2 Hi Temp and Thermal Shock
		4.1.1.3 High Relative Humidity Storage
		4.1.2 Operating Temp and Relative Humidity
		4.1.3 Altitude
		4.2.2 Equipment Assy Fire Spread
		4.2.3 Needle Flame
		4.3.1 Packaged Equipment Criteria
		4.3.2 Unpackaged Equipment Drop
		4.4.1 Earthquake
		4.4.3 Office Vibration
		4.4.4 Transportation Vibration
		4.5 Airborne Contaminants
		4.5 Hygroscopic Dust
		4.6 Noise
		4.7 Illumination

Related Publications

Listed below are manuals that may be useful to users of this one.

Table 1.2 Related Documentation

Document Number	Title
060681-001	DV6000 Digital Video Transmission System Installation and Operation
861684	DV6408 Tributary Access System Equipment Manual (2nd Gen.)
060856-001	DV6010 Digital Video Transmission System Installation and Operation
060660-001	DV6016RPS Repeater Shelf Installation and Operation Manual
060834-001	DV6000 SMART-NETT Model #9903 User's Manual
1054575	DV6000 DAP Control Software User's Manual
1031165	DV6400 Tributary Access and Interface Gateway Procedures Manual
862339	DV6000 Product Family Modules (Encoder, Decoder, and Tributary Modules)
862934	Multi-Port DVB-ASI & SMPTE 310M Encoder/Decoder Equipment Manual
862118	DV6016DAP4 Drop/Add/Pass (DAP4) Module Equipment Manual
862119	SONET/SDH Optics Module Equipment Manual
861565	Information & Monitoring Interface (IMI) Software User's Guide
862118	DV6016DAP4 Drop/Add/Pass (DAP4) Module Equipment Manual
1500791	DV6SDI SD-SDI/HD-SDI/DVB-ASI Equipment Manual

Tools and Materials

Table below provides a complete list of the tools and materials required to install and or maintain the equipment. The Use column indicates where and/or when they are required. Each procedure in this manual will list those tools and materials required to perform that particular task.

Tools/Materials	Required Characteristics	Uses
Tools		
Box cutter		Unpacking shelf and plug-in modules
Power Meter	Optical Power Meter	To verify active fiber optic cables
Screwdriver	Slotted, blade no larger than 0.138-inch (Xcelite® R-182, or equivalent)	Connecting alarm relay contacts
Screwdriver	#1 Phillips-head	Removal of module cover to instal/replace SFP transceivers
Wire strippers		Connecting alarm relay contacts
Materials		
ESD antistatic mat		Any procedure when module is not in the equipment shelf
ESD wrist strap		All procedures
Wire	24–14 AWG, stranded or solid, shielded, twisted, pair (Belden 7837A or Belden 8441, or equivalent)	Connecting alarm relay contacts

Acronyms and Abbreviations

Abbrev.	Definition	Abbrev.	Definition
ASI	Asynchronous Serial Interface	MSA	MultiSource Agreement
CLI	Command Line Interface	MSO	Multi Service Operators
CWDM	Coarse Wave Division Multiplexing	NVM	Non-Volatile Memory
DVB	Digital Video Broadcasting	OSS	Operational Support Systems
DWDM	Dense Wave Division Multiplexing	SD	Standard Definition digital video
EDH	Error Detection and Handling	SDI	Serial Digital Interface
EMS	Elemental Management Software	SFP	Small Form-Factor Pluggable Module
HD	High Definition digital video	SMPTE	Society of Motion Picture and Television Engineers
MPEG	Moving Picture Expert Group	SNMP	Simple Network Management Protocol

DV270SDI Modules

This chapter provides information common to both the DV270SDIT Transmitter and DV270SDIR Receiver modules.

Overview—page 2-1

Applications—page 2-2

Network Management—page 2-4

Part Numbers—page 2-4

Overview

The DV270SDIT Transmitter and DV270SDIR Receiver module pairs for the DV6000 and DV6408 product lines interface directly to another DV270SDI or DV6SDI module. Each module occupies two slots in the DV6000 or DV6408 card cages.

The DV270SDIT Transmitter is capable of processing ASI or SD-SDI electrical input signal from two adjacent slots in the DV backplane and outputting an optical signal using an industry standard SFP optical transceiver module.

The DV270SDIR Receiver is able to receive an optical signal from a DV270SDIT or a DV6SDIT card (270Mbps only-SD) and accordingly process the received optical signal onto two adjacent slots of the DV backplane.

SPFs

SFP optical transceiver modules (ordered separately) interface to the DV270SDI modules. Refer to Appendix A, for a list of those SFP modules that have been tested in the DV270SDI line cards, and are functionally certified.

When a new SFP transceiver module is installed, the module will identify the SFP:

- SFP Manufacturer
- Laser wavelength
- Link length supported for 9/125 μ m fiber

Applications

and update the NEID Configuration Destination field with this information.

- If an SFP is not installed, the Configuration Destination field will indicate **Laser Not Installed**.
- If an SFP is installed but does not support digital diagnostics, the Configuration Destination field will indicate **Laser Type Unknown**.

The SDI/DVB-ASI modules can transport uncompressed standard definition serial digital video or compressed MPEG-2 video (in a DVB-ASI format). Additionally the tributary modules can interface remote SDI/DVB-ASI to the DV6000 or DV6400 multiplexed datastream. Once encoded, the signals can be transported, along with any of the other signal types that the DV interfaces (NTSC, PAL, IF, QAM, DS3, etc.), to matching decoders at one or more locations throughout a network.

Figure 2.1

Applications

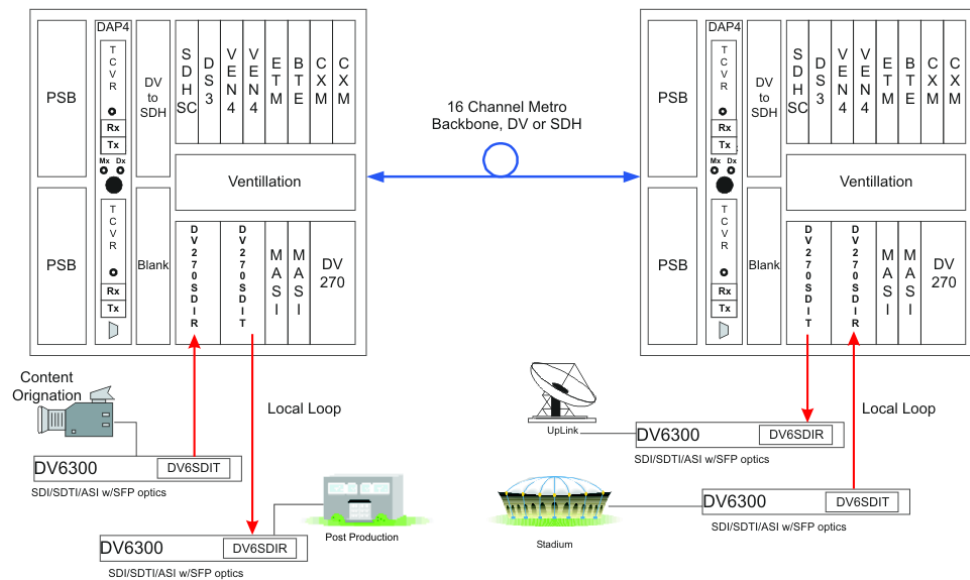
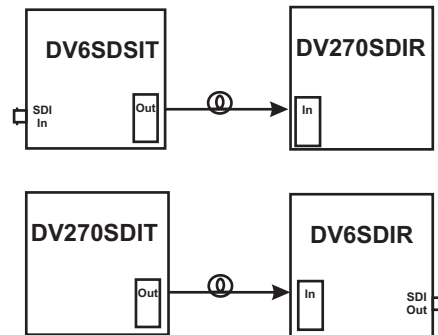

Figure 2.2

DV6SDI to DV270SDI



Transmit and receiver SD-SDI signals or DVB-ASI signals using DV6000/DV6400 nodes.

Figure 2.3

DV6SDI to DV270DVBx

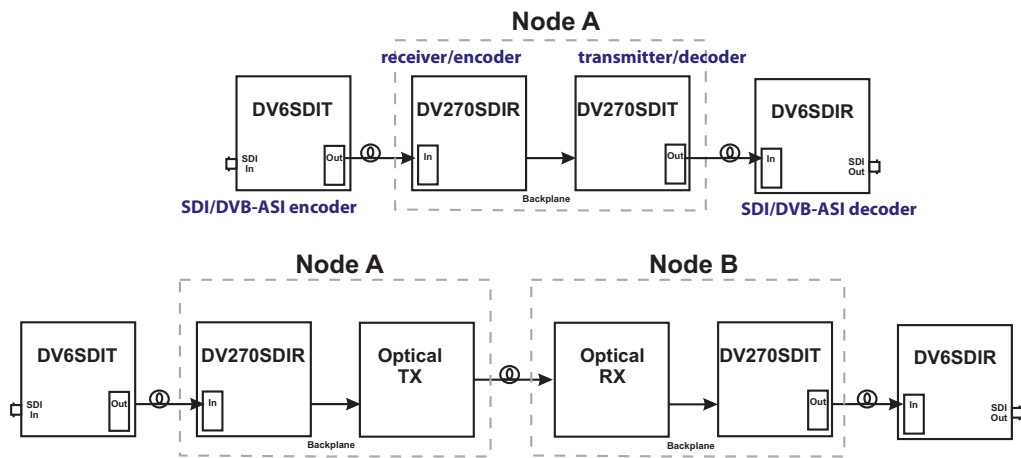

Transmit and receiver SD-SDI signals or DVB-ASI signals using DV6000/DV6400 nodes.

Network Management

The following network management methodologies/access are available for the DV270SDI modules.

DV6400 Craft Software

Craft supports monitoring and alarms of the DV270SDI. Refer to appropriate transport Craft User's Manual for details.

DV6000 DAP2 and DV6300/DVFE Configuration Tools

Craft supports monitoring and alarms of the DV270SDI. Refer to appropriate transport Craft User's Manual for details.

DV6016DAP4 MDI Software

The DAP4 MDI software will support monitoring and alarms of the DV270SDI. Refer to DV6016DAP401 Drop/Add/Pass (DAP4) Module Equipment Manual (862118) for details

IMI 9000 Monitoring Interface Software

IMI supports monitoring and alarms of the DV270SDI. Refer to Information & Monitoring Interface (IMI) Software User's Guide (861565) for details.

Part Numbers

The DV270SDI module options are specified when the modules are ordered. Table 2.1 provides a description of the model numbers available.

Table 2.1 DV270SDI Module Part Numbers

Part Number	Description
DV270SDIT	SD-SDI/DVB-ASI Transmitter module, FC optical connectors (less SFP optics)
DV270SDITSC	SD-SDI/DVB-ASI Transmitter module, SC optical connectors (less SFP optics)
DV270SDIR	SD-SDI/DVB-ASI Receiver module, FC optical connectors (less SFP optics)
DV270SDIRSC	SD-SDI/DVB-ASI Receiver module, SC optical connectors (less SFP optics)
See Appendix A	Refer to Appendix A, for a complete list of qualified SFPs available at this time: Table A.2, <i>DV270SDI Qualified Standard SFP Specifications</i> —page A-2, Table A.3, <i>DV270SDI Qualified CWDM SFP Specifications</i> —page A-2 Table A.4, <i>DV270SDI Qualified DWDM SFP Specifications</i> —page A-3

DV270SDIT Transmitter Module

This chapter provides information on the DV270SDIT Transmitter module.

Overview—page 3-1

Physical Description—page 3-2

Functional Description—page 3-6

Module Control and Alarms—page 3-8

– Table , *DV270SDIT Transmitter Parameters - Decoder (Right Slot)*—page 3-8

– Table , *DV270SDIT Transmitter - CPU Alarm Status (Left Slot)*—page 3-9

Part Numbers—page 3-10

Overview

The DV270SDIT is capable of processing ASI or SD-SDI electrical input signal from two adjacent slots in the DV backplane and outputting an optical signal using an industry standard SFP optical transceiver module.

A standard SFP optical transceiver module (ordered separately) interfaces to the DV270SDI modules. Only those standard SFP optical transceiver modules listed as official Artel model numbers (refer to Appendix A) are functionality certified.

Physical Description

Front Panel

Figure 3.1 is a front view of the DV270SDIT Transmitter module front panel.

Figure 3.1

DV270SDIT
Transmitter Front
Panel

3

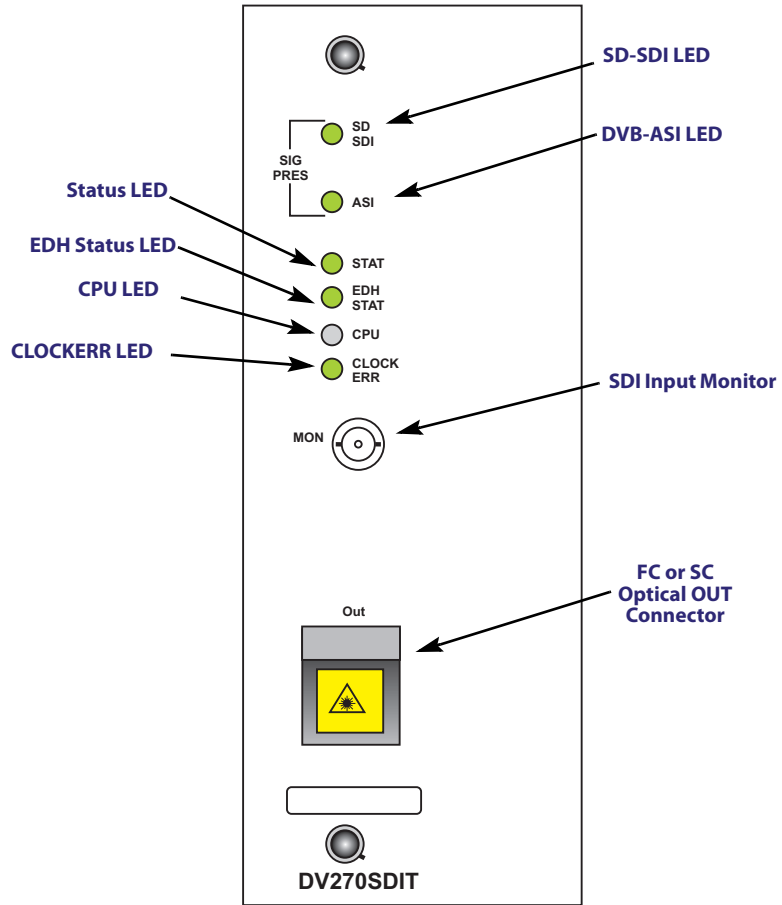

Table 3.1 provides a brief description of each of the DV270SDIT Transmitter front panel features.

Table 3.1 DV270SDIT Transmitter Front Panel Features

Type	Label	Description
LED (green/red/unlit)	SD SDI	<i>Green:</i> Indicates normal operation. Module powered and valid SD-SDI signal present at BNC input. <i>Red:</i> Module powered and no valid signal present at BNC input. <i>Unlit:</i> Power not applied or SD-SDI signal not present at BNC input.
LED (green/red/unlit)	ASI	<i>Green:</i> Indicates normal operation. Module powered and valid DVB-ASI signal present at BNC input. <i>Red:</i> Module powered and no valid signal present at BNC input. <i>Unlit:</i> Power not applied or DVB-ASI signal not present at BNC input.
LED (green/red/unlit)	STAT	<i>Green:</i> SFP installed and module not in alarm <i>Red: Flashing.</i> Optical transmitter alarm <i>Unlit:</i> Power not applied or SFP improperly installed.
LED (green/red/unlit)	EDH STAT	<i>Green:</i> EDH present at incoming signal and not in alarm. <i>Red:</i> EDH present at incoming signal and in alarm. <i>Unlit:</i> Power not applied or EDH not present at incoming signal
LED (red/unlit)	CLOCK ERR	<i>Red:</i> Module is powered and the board is disabled (i.e. no upstream encoder present). <i>Unlit:</i> Module not powered or has a valid clock.
LED (green/unlit)	CPU	<i>Green:</i> Module is powered and CPU is running properly. <i>Green: Flashing.</i> Module is powered and OSS communications. <i>Unlit:</i> Module not powered or CPU has failed.
BNC (Connector)	MON	Input monitor port. Printed Circuit Board Cable Configuration¹: Front panel MON cable connects to CPU SMB receptacle J11
FC or SC (Connector)	Out	Optical output from SFP transceiver.

1. Refer to Figure 3.2 (cable connections), and Figure 3.3 (block diagram) for details.

Hot-swapping the module does not damage the modules. However, it will terminate data. To prevent loss of data, switch data stream to another transmitter prior to removing the module in question.

Rear Panel

Table 3.2 indicates the DV270SDIT Transmitter rear panel connectors. These connectors can be accessed from the rear panel of the DV shelf/assembly, (JnA and JnB), where “n” indicates the slot that the module is inserted). Refer to *To connect DV270SDI electrical signals* on page 5-11 for physical connection locations.

The Labels shown in brackets are only on the DV6408 chassis. Since this is a two card module, the “Slot” column indicates which module slot the signals can be accessed.

Table 3.2 DV270SDIT Transmitter Rear Panel Connections

Type	Label	Slot	Description
BNC Connector	JnB VIDEO LOOP THRU (Top Connector)	Right	A serial data monitor from the decoder port. Printed Circuit Board Cable Configuration¹: SMB cable from decoder SMB receptacle J5 to decoder SMB receptacle J6 (access at VIDEO LOOP THRU BNC connector [JnB] on the rear panel of the shelf).
BNC Connector	JnA VIDEO IN/OUT (Bottom Connector)	Right	A serial data monitor from the decoder port. Printed Circuit Board Cable Configuration¹: Rear panel VIDEO IN/OUT BNC cable connects to decoder SMB receptacle J3

1. Refer to Figure 3.2 (cable connections), and Figure 3.3 (block diagram) for details.

One set of contacts for indicating a local minor alarm within the decoder is provided. Connection to the alarm contacts are made to the channel “**A**” spare audio contacts, associated with the decoder board side of the module, on the back of the equipment shelf.

The alarm conditions listed in Tables 3.3 and 3.5 through 3.7 will cause a minor alarms.

DV270SDIT Transmitter Board Configuration

The DV270SDIT Transmitter is a two card module consisting of a CPU card (left slot position in the shelf) and a decoder card (right slot position in the shelf). SMB cables are used to interconnect the SDI signals between cards, as well as to the assembly front and shelf rear panels.

Assembly Internal Coax Connections

Figure 3.2 indicates the default SMB cable connections between the transmitter module CPU and decoder cards.



Note The fan assembly is installed on all transmitter modules.

Figure 3.2

**DV270SDIT
Transmitter-Decoder
Printed Circuit Board
Connections**

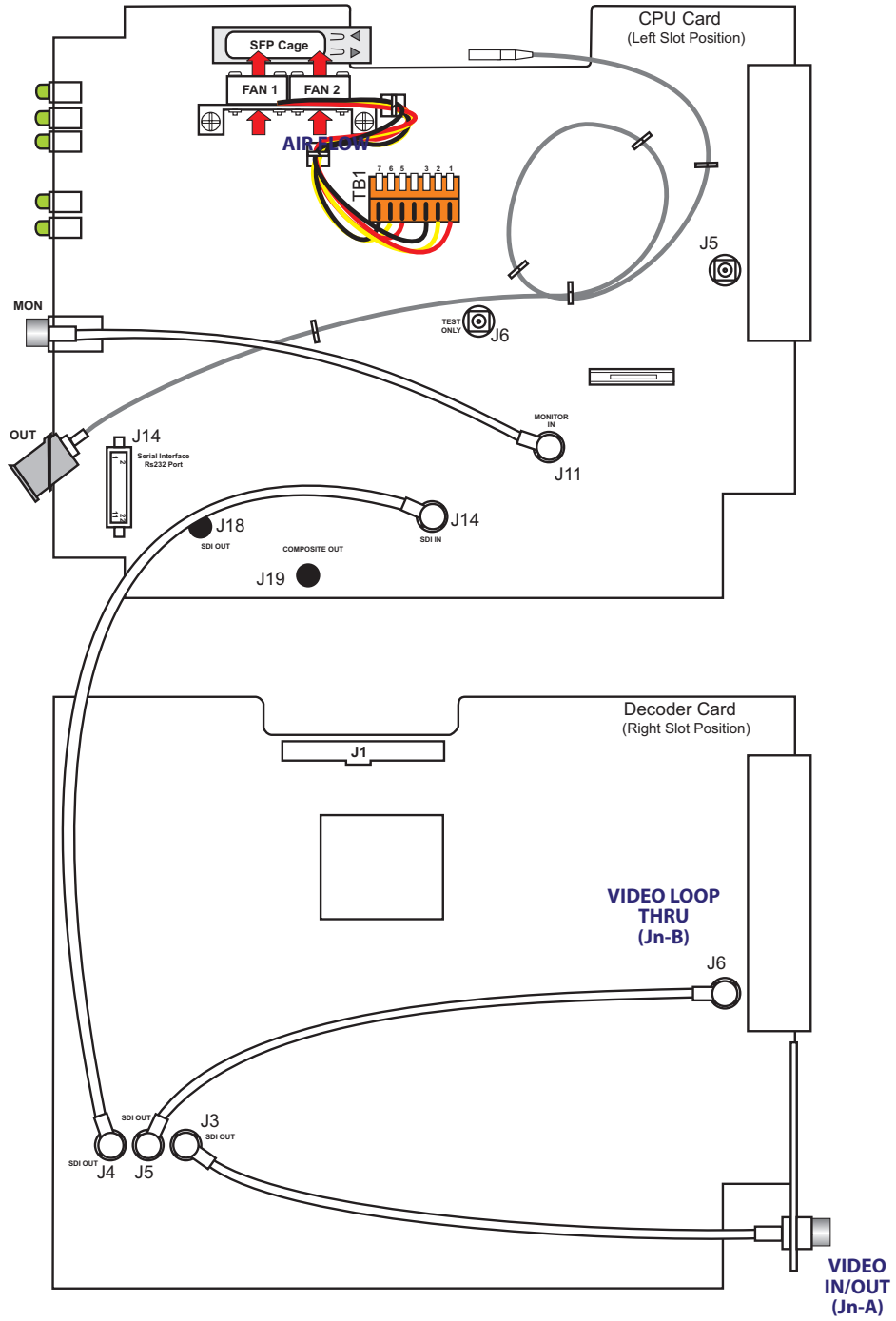

Functional Description

The DV270SDIT Transmitter/decoder module receives data from the DV6000 or DV6408 backplane from an upstream encoder, converts it back into the original signal and transmits a compliant serial digital signal to the output BNC **F** connector on the back of the shelf and to the SFP optical transmitter. The optical signal is then made available at the front panel optical **OUT** connector. The optical signal going out the transmitter is a scrambled version of the compliant SDI signal.

- Due to bandwidth requirements, the decoder module takes up two timeslots in the DV6016ES or DV6408 system.
- Alarm contacts provide local alarming for the decoder. Connection to these contacts are made through the channel **A** audio terminal blocks located on the back of the DV6000 or DV6408 equipment shelf.
- The decoder automatically configures itself for SMPTE or DVB mode based on the incoming data from the upstream encoder. With no upstream encoder present, the decoder shall remain disabled with no operating mode selected. When the decoder is disabled, or enabled with no signal present, the outputs of the decoder shall be a zero volt DC signal.

Figure 3.3 is a simplified block diagram of the DV270SDIT Transmitter.

Figure 3.3

DV270SDIT Transmitter Module Block Diagram

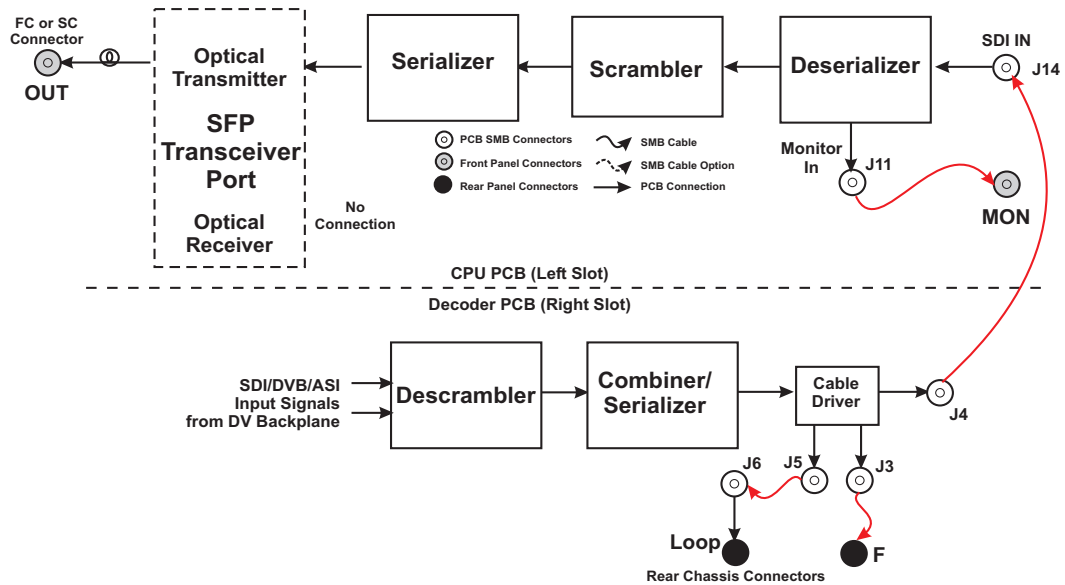

The DV270SDIT Transmitter module accepts one (1) of the following electrical signals from the two adjacent slots of the DV backplane (DV6000, DV6408):

- EN 50083-9:1997 compliant DVB-ASI
- SMPTE 259M-C compliant SD-SDI

The signal is deserialized and sent to a scrambler and then serialized. Through a cable driver it is made available to:

- A MAIN output as an SMPTE 259M-C or annex B.3.1.1 of EN 50083-9:1997 compliant signal. Connection to the MAIN output shall be made through the **VIDEO IN/OUT** BNC connector located on the back of the DV6016ES and DV6408 equipment shelf.
- A second output is available on a BNC connector located on the rear of the DV shelf (DV6000, DV6408 **VIDEO LOOP THRU** connection). When upstream video is present, both outputs shall be active simultaneously.
- The signal is also sent to the **MON** front panel connector input signal monitor.

A multi-rate deserializer is used to perform NRZI-to-NRZ decoding, descrambling, and error correction as required by the input signal format.

The video data is then sent to the scrambler where it is sufficiently scrambled to support DWDM optical transmission. From there to a multi-rate serializer to perform NRZ-to-NRZI encoding and scrambling, 8bit/10bit encoding, packet generation, or CRC generation as required by the signal input format.

The optical transmitter (SFP) accepts the serial data from the multi-rate serializer and supports the following:

- DWDM SFP (field pluggable) MSA Compliant, C-band, 100GHz channel spacing
- CWDM SFP (field pluggable) MSA Compliant, C-band, 20nm channel spacing
- Data rate functionality of 270Mbps
- Short reach long reach (see Appendix A, Table A.1 for details))

The output is then made available at the front panel optical connector (**OUT**).

A monitor port (**MON**) is provided to view the input signal.

Module Control and Alarms

The DV270SDIT Transmitter status/alarms can be viewed locally at the line card front panel LEDs, or accessed locally via the DAP2 Configuration Tool, DV6300/DVFE Configuration Tool, DV6400 Craft software, DV6016DAP4 MDI, or remotely via the IMI 9000 Monitoring System.



Note The DV270SDIT Transmitter is a dual-width module and takes up two shelf slots. Menu shown will depend upon which encoder/decoder shelf slot was accessed from the Encoder/Decoder Module Alarms Main Menu.

3

DV270SDIT Transmitter Parameters - Decoder (Right Slot)

Table 3.3 indicates the DV270SDIT Transmitter Decoder status/alarms.

Table 3.3 DV270SDIT Transmitter Decoder Alarms

DAP4 Parameter	Alarm	Comments
1–Signal	OK or Minor	Indicates that signal is present
2–FIFO	OK or Minor	FIFO overflow/underflow, out of frequency range
6–Disable/Clock	OK or Minor	Indicates if the card is enabled/disabled or loss of backplane clock
5–CPU Fault	OK or Minor	Indicates that the CPU internal self test failed

Table 3.4 defines the default threshold settings.

Table 3.4 DV270SDIT Transmitter Decoder Default Threshold Settings

DAP4 Parameter	Threshold			
	Minor		Major	
	Lo	Hi	Lo	Hi
1–Signal	0	160	0	255
2–FIFO	0	160	0	255
6–Disable/Clock	0	160	0	255
5–CPU Fault	160	255	0	255

DV270SDIT Transmitter - CPU Alarm Status (Left Slot)

Steps 3.5 through 3.8 DV270SDIT Transmitter status/alarms.

- All the network management tools (except for the DAP4 MDI) will provide the Status and Alarm conditions in readable format (refer to “Status” and “Alarms” columns in the below tables).
- The DAP4 MDI software will provide a single decimal number that indicates both the Status and Alarm information. Refer to “DAP4 MDI Value column” in the below tables then read across for the Status and/or Alarm information.

Table 3.5 indicates the DV270SDIT Transmitter I/O Status information.

Table 3.5 DV270SDIT Transmitter I/O Status

Parameter	Status		Alarm	DAP4 MDI Value (decimal #)	Description
	No Signal In	“x” Present In	No Signal In		
1 –I/O Status		SD		1	SD-DI signal present at BNC input
		DVB		3	DVB-ASI signal present at BNC input
	X		X	16	No valid signal present at BNC input, in alarm

Table 3.6 indicates the DV270SDIT Transmitter Tx Status information.

Table 3.6 DV270SDIT Transmitter Tx Status

Parameter	Status		Alarm			DAP4 MDI Value (decimal #)	Description
	SFP Installed	SFP Not Installed	Fan/Temp Tx	Optical Tx	SFP Not Installed		
2 –Tx Status	X					1	SFP properly installed, no alarms
		X				16	SFP not present or properly installed alarm
	X			X		33	Optical transmitter alarm
	X		X			65	Fan/temperature alarm
		X			X	80	SFP not present or properly installed and Fan/Temp alarm
	X		X	X		97	Optical transmitter and Fan/temperature alarms

Table 3.7 indicates the DV270SDIT Transmitter EDH Status information.

Table 3.7 DV270SDIT Transmitter EDH Status

Parameter	Status		Alarm	DAP4 MDI Value (decimal #)	Description
	EDH Present	EDH Not Present Tx	EDH Tx Error		
3-EDH Status		X		0	EDH not present at incoming signal
	X			1	EDH present at incoming signal and no alarm
	X		X	17	EDH present at incoming signal and in alarm

Table 3.8 indicates the DV270SDIT Transmitter fourth Status information block, but is not used for the transmitter.

Table 3.8 DV270SDIT Transmitter Unused Status

Parameter	Status	Alarm	DAP4 MDI Value (decimal #)	Description
	n/a	n/a		
4-Unused Status			0	Unused

Default thresholds have been selected to report segmental alarms as minor alarms. There are no major alarms defined for this card.

Controls

There are no firmware/software controls for this line card.

One set of contacts for indicating a local minor alarm within the decoder is provided. Connection to the alarm contacts shall be made to the channel “A” spare audio contacts, associated with the decoder board side (right slot) of the module, on the back of the equipment shelf.

Part Numbers

The DV270SDIT Transmitter options are specified when the modules are ordered. Table 3.9 provides a description of the model numbers.

Table 3.9 DV270SDIT Transmitter Part Numbers

Part Number	Description
DV270SDIT	SD-SDI/DVB-ASI Transmitter module, FC optical connectors (less SFP optics)
DV270SDITSC	SD-SDI/DVB-ASI Transmitter module, SC optical connectors (less SFP optics)
1500732	Fan assembly (dual fans w/pigtails)
See Appendix A	Refer to Appendix A, for a complete list of qualified SFPs available at this time: Table A.2, <i>DV270SDI Qualified Standard SFP Specifications</i> —page A-2, Table A.3, <i>DV270SDI Qualified CWDM SFP Specifications</i> —page A-2 Table A.4, <i>DV270SDI Qualified DWDM SFP Specifications</i> —page A-3

DV270SDIR Receiver Module

This chapter provides information on the DV270SDIR Receiver module.

Overview—page 4-1

Physical Description—page 4-2

Functional Description—page 4-6

Module Control and Alarms—page 4-8

– *DV270SDIR Receiver Parameters - Encoder (Right Slot)*—page 4-8

– *DV270SDIR Receiver CPU Alarm Status (Left Slot)*—page 4-9

Part Numbers—page 4-10

Overview

The DV270SDIR receives an optical signal from a DV270SDIT or a DV6SDIT card (270 Mb only-SD) and accordingly process the received optical signal onto two adjacent slots of the DV backplane.

A standard SFP optical transceiver module (ordered separately) interfaces to the DV270SDI modules. Only those standard SFP optical transceiver modules listed as official Artel model numbers (refer to Appendix A) are functionality certified.

Physical Description

Front Panel

Figure 4.1 is a front view of the DV270SDIR Receiver module front panel.

Figure 4.1

DV270SDIR Receiver
Front Panel

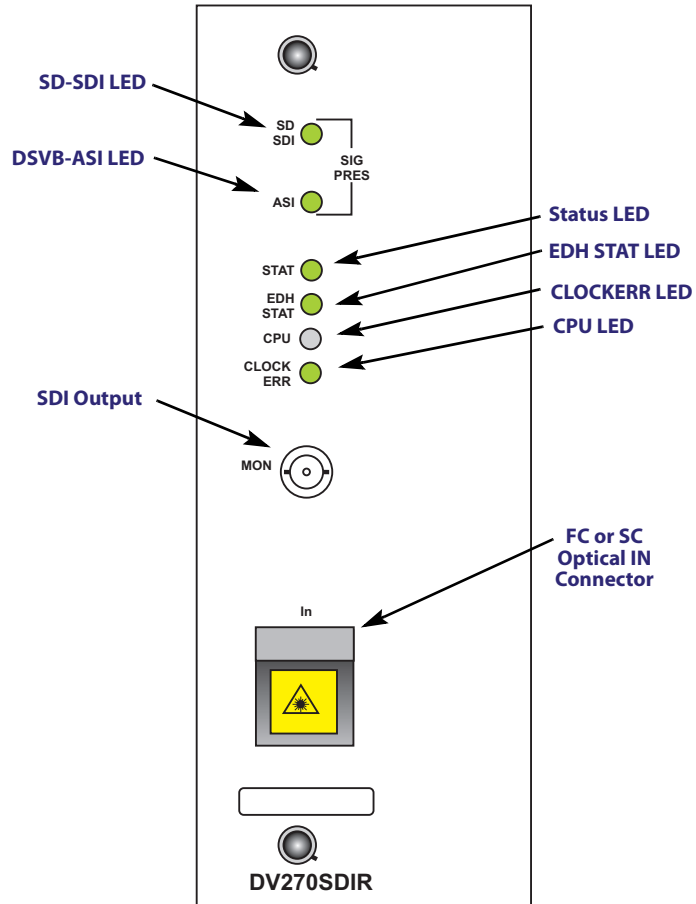

Table 4.1 provides a brief description of each of the DV270SDIR Receiver front panel features.

Table 4.1 DV270SDIR Receiver Front Panel Features

Type	Label	Description
LED (green/red/unlit)	SD SDI	<i>Green:</i> Indicates normal operation. Module powered and valid SD-SDI signal present at BNC output. <i>Red:</i> Module powered and no valid signal present at BNC output. <i>Unlit:</i> Power not applied or no SD-SDI signal present at BNC output.
LED (green/red/unlit)	ASI	<i>Green:</i> DVB-ASI signal present at BNC output. <i>Red:</i> Module powered and no valid signal present at BNC output. <i>Unlit:</i> Power not applied or no DVB-ASI signal present at BNC output.
LED (yellow/red/unlit)	STAT	<i>Yellow:</i> Module is powered and receive signals are out of range (high) <i>Red:</i> Module is powered and receive signals are out of range (low). <i>Unlit:</i> Indicates normal operation. Module powered and receiver is not in alarm.
LED (green/red/unlit)	EDH STAT	<i>Green:</i> EDH present at incoming fiber signal and not in alarm. <i>Red:</i> EDH present at incoming signal and in alarm. <i>Unlit:</i> Power not applied or EDH is not present at incoming signal.
LED (red/unlit)	CLOCK ERR	<i>Red:</i> Module is powered and violates the bit rate permitted by the DV270SDIR, or if the DV270SDIR is disabled. ¹ <i>Unlit:</i> Module not powered or has a valid clock.
LED (green/unlit)	CPU	<i>Green:</i> Module is powered and CPU is running properly. <i>Green: Flashing:</i> Module is powered and OSS communications. <i>Unlit:</i> Module not powered or CPU has failed.
BNC (Connector)	MON	Input monitor port. Printed Circuit Board Cable Configuration²: Front panel MON cable connects to encoder SMB receptacle J4
FC or SC (Connector)	In	Optical input to SFP transceiver.

1. This indicator will be lit for three seconds after each occurrence
2. Refer to Figures 4.2 (cable connections), and Figure 4.3 (block diagram) for details.

Hot-swapping the module does not damage the modules. However, it will terminate data. To prevent loss of data, switch data to another module prior to removing the module in question.

Rear Panel

Table 4.2 indicates the DV270SDIR Receiver rear panel connectors. These connectors can be accessed from the rear panel of the DV shelf/assembly, (JnA and JnB, where “n” indicates the slot that the module is inserted). Refer to *To connect DV270SDI electrical signals* on page 5-11 for physical connection locations.

The Labels shown in brackets are only on the DV6408 chassis. Since this is a two card module, the “Slot” column indicates which module slot the signals can be accessed.

Table 4.2 DV270SDIR Receiver Rear Panel Connections

Type	Label	Slot	Description
BNC Connector	JnB VIDEO LOOP THRU (Top Connector)	Left)	A 75-ohm Analog NTSC/PAL output. Printed Circuit Board Cable Configuration¹: SMB cable from CPU SMB receptacle J19 to CPU SMB receptacle J5 (access at VIDEO LOOP THRU BNC connector [JnB] on the rear panel of the shelf).
BNC Connector	JnA VIDEO IN/OUT (Bottom Connector)	Right)	A serial data monitor from the Encoder port. Printed Circuit Board Cable Configuration²: Rear panel VIDEO IN/OUT [Jn-A] BNC cable connects to encoder SMB receptacle J5

1. Refer to Figures 4.2 (cable connections), and Figure 4.3 (block diagram) for details.

One set of contacts for indicating a local minor alarm within the encoder is provided. Connection to the alarm contacts are made to the channel “A” spare audio contacts, associated with the encoder board side of the module, on the back of the equipment shelf.

The alarm conditions listed in Tables 4.3 and 4.5 through 4.8 will cause a minor alarm.



Note The DV270SDIR Receiver is capable of being configured to take an input from the rear panel rather than the optical receiver.

DV270SDIR Receiver Printed Circuit Board SMB Connectors

The DV270SDIR Receiver is a two card module consisting of a CPU card (left slot position in the shelf) and an Encoder card (right slot position in the shelf). SMB cables are used to interconnect the SDI signals between cards as well as to the assembly front and shelf rear panels.

Assembly Internal Coax Connections

Figure 4.2 indicates the default SMB cable connections between the receiver module CPU and encoder cards.

Figure 4.2

**Receiver-Encoder
Printed Circuit Board
Connections**

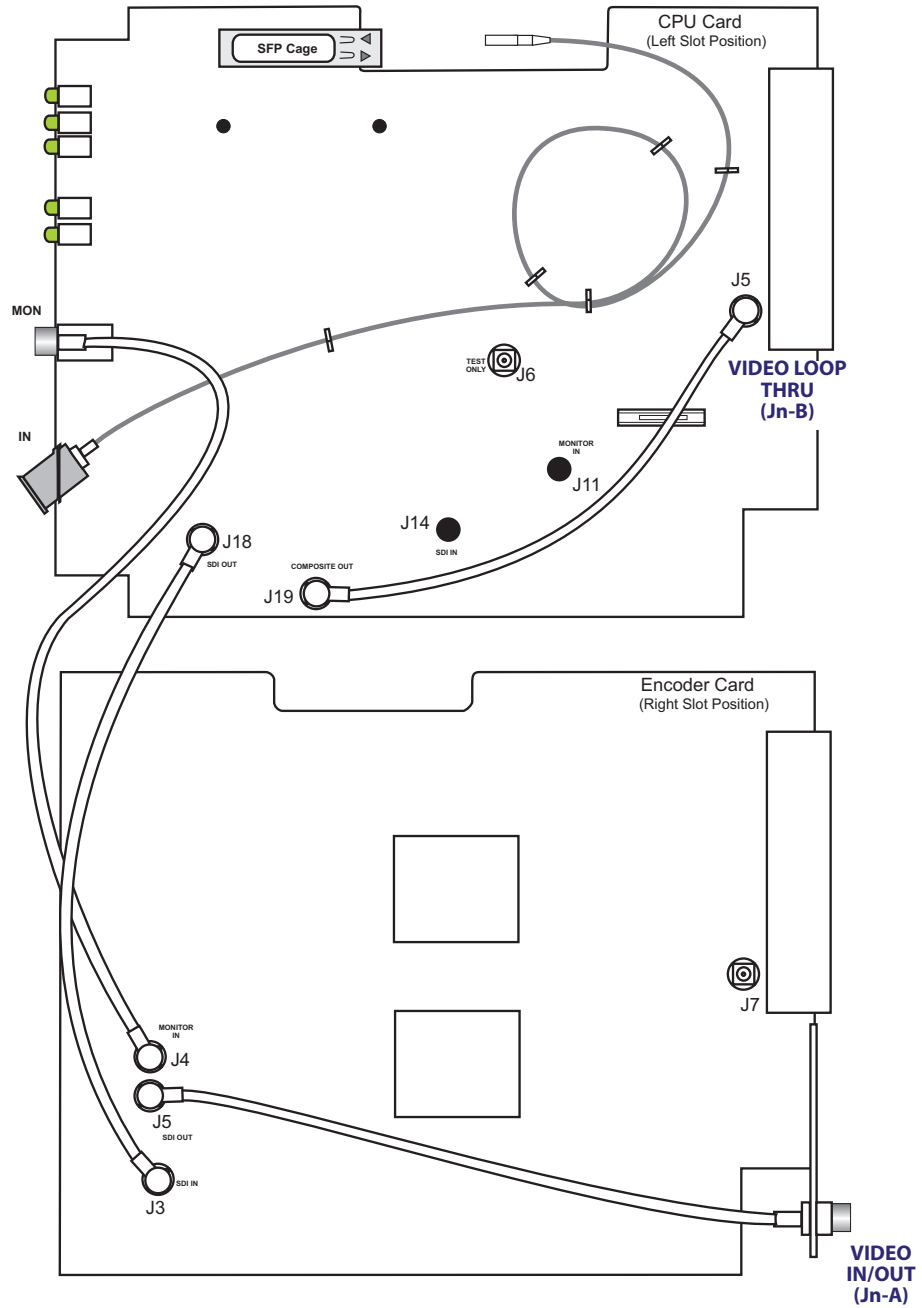

Functional Description

The DV270SDIR Receiver is responsible for receiving an SDI or ASI signal optically from an upstream DV6SDIT (270Mbps only) or DV270SDIT, processing it, and inserting it into the DV proprietary data stream. The DV270SDIR takes up two timeslots in the Mx2, DAPX or DV6408 systems.

The DV270SDIR Receiver has one optical input. A post equalized video outputs are provided.

When power is applied to the DV270SDIR, it will operate in the last user-defined mode, prior to power removal.

Alarm contacts providing local alarming for the encoder is provided. Connection to these contacts are made through the channel "A" audio terminal blocks located on the back of the DV6016ES or DV6408 equipment shelf.

Figure 4.3 is a simplified block diagram of the DV270SDIR Receiver.

Figure 4.3

DV270SDIR Receiver Block Diagram

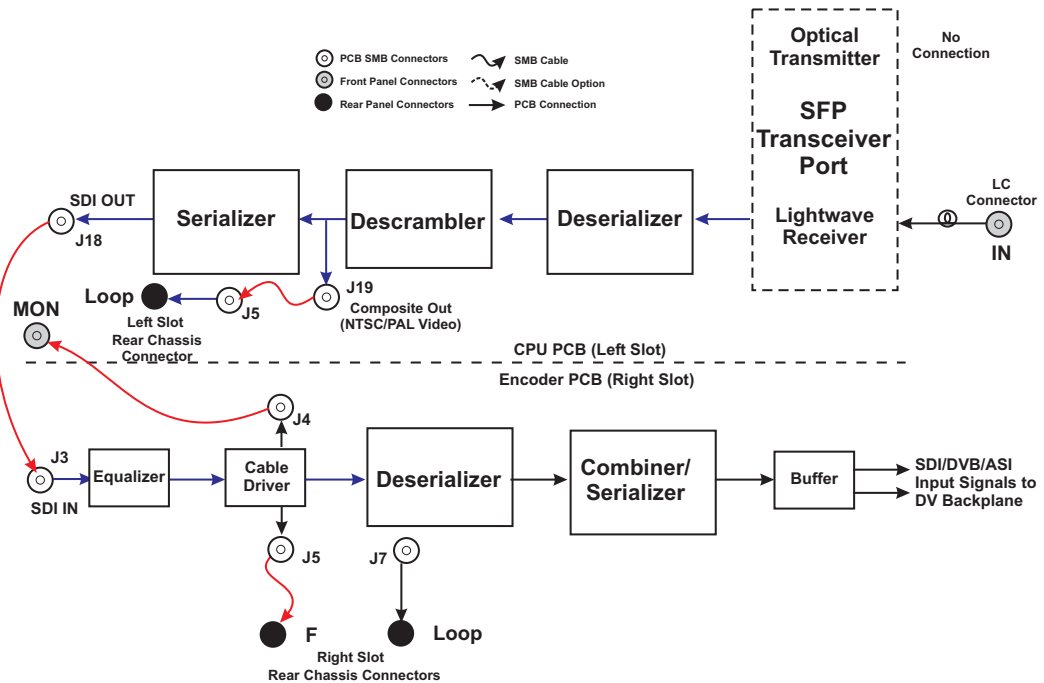

The optical receiver shall accept serial data from a DVSDIT module or from a DV270SDIT module. The following shall be supported:

- Data rate functionality of 270Mbps
- Typical wavelengths from 1310nm to 1550nm

In this applications the SFP transmitter is disabled. From the receiver, a multi-rate deserializer is used to perform NRZI-to-NRZ decoding, descrambling, and error correction as required by the input signal format. The video data is then sent to the descrambler where it is descramble to an exact match of the original SMPTE 259M-C signal or EN 50083-9:1997 compliant DVB-ASI signal. From there to a multi-rate serializer to perform NRZ-to NRZI encoding and scrambling, 8bit/10bit encoding, or packet generation as required by the signal input format.

The DV270SDIR module will then output one (1) of the following signals onto two adjacent slots of a DV backplane:

- EN 50083-9:1997 compliant DVB-ASI
- SMPTE 259M-C compliant SD-SDI

There are two video outputs on the DV270SDIR:

- The MAIN output is a SMPTE 259M-C or annex B.3.1.1 of EN 50083-9:1997 compliant signal. Connection to the MAIN output shall be made through the **VIDEO IN/OUT** BNC connector located on the back of the DV6016ES and DV6408 equipment shelf.
- A second output is also available on a BNC connector located on the rear of the DV shelf (DV6000, DV6408 loop connection). When upstream video is present, both outputs shall be active simultaneously. With no video present, both outputs shall be 0 VDC.

A monitor port (**MON**) is provided to view the input signal (refer to Figure 4.3). The Loop output on the left slot is for NTSC/PAL video outputs.

Module Control and Alarms

The DV270SDIR Receiver status/alarms can be viewed locally at the line card front panel LEDs, or accessed locally via the DAP2 Configuration Tool, DV6300/DVFE Configuration Tool, DV6400 Craft software, DV6016DAP4 MDI, or remotely via the IMI 9000 Monitoring System.



Note The DV270SDIR Receiver is a dual-width module and takes up two shelf slots. Menu shown will depend upon which encoder/decoder shelf slot was accessed from the Encoder/Decoder Module Alarms Main Menu.

DV270SDIR Receiver Parameters - Encoder (Right Slot)

Table 4.3 indicates the DV270SDIR Receiver Encoder status/alarms.

Table 4.3 DV270SDIR Receiver Encoder Alarms

DAP4 Parameter	Alarm	Comments
1–Signal	OK or Minor	Indicates that signal is present
2–FIFO	OK or Minor	FIFO overflow/underflow, out of frequency range
6–Disable/Clock	OK or Minor	Indicates if the card is enabled/disabled or loss of backplane clock
5–CPU Fault	OK or Minor	Indicates that the CPU internal self test failed

Table 4.4 defines the default threshold settings.

Table 4.4 DV270SDIR Receiver Encoder Default Threshold Settings

DAP4 Parameter	Threshold			
	Minor		Major	
	Lo	Hi	Lo	Hi
1–Signal	0	160	0	255
2–FIFO	0	160	0	255
6–Disable/Clock	0	160	0	255
5–CPU Fault	160	255	0	255

DV270SDIR Receiver CPU Alarm Status (Left Slot)

Steps 4.5 through 4.8 DV270SDIR Receiver status/alarms

- All the network management tools (except for the DAP4 MDI) will provide the Status and Alarm conditions in readable format (refer to “Status” and “Alarms” columns in the below tables).
- The DAP4 MDI software will provide a single decimal number that indicates both the Status and Alarm information. Refer to “DAP4 MDI Value column” in the below tables then read across for the Status and/or Alarm information.

Table 4.5 indicates the DV270SDIR Receiver I/O Status information.

Table 4.5 DV270SDIR Receiver I/O Status

Parameter	Status		Alarm	DAP4 MDI Value (decimal #)	Description
	No Signal Out	“x” Present Out	No Signal In		
1-I/O Status		SD		1	SD-DI signal present at BNC output
		DVB		3	DVB-ASI signal present at BNC output
	X		X	16	No valid signal present at BNC output, in alarm

Table 4.6 indicates the DV270SDIR Receiver Tx Status information.

Table 4.6 DV270SDIR Receiver Tx Status

Parameter	Status		Alarm		DAP4 MDI Value (decimal #)	Description
	SFP Installed	SFP Not Installed	Temp Rx	SFP Not Installed		
2-Tx Status	X				1	SFP properly installed, no alarms
		X		X	16	SFP not present or properly installed alarm
	X		X		33	Temp Rx alarm
		X	X	X	48	SFP not present or properly installed and Temp Rx alarm

Table 4.7 indicates the DV270SDIR Receiver EDH Status information.

Table 4.7 DV270SDIR Receiver EDH Status

Parameter	Status		Alarm	DAP4 MDI Value (decimal #)	Description
	EDH Present Rx	EDH Not Present Rx	EDH Rx Error		
3 – EDH Status		X		0	EDH not present at incoming fiber signal
	X			1	EDH present at incoming fiber signal
	X		X	17	EDH present at incoming fiber signal and in alarm

Table 4.8 indicates the DV270SDIR Receiver Rx Status information.

Table 4.8 DV270SDIR Receiver Rx Status

Parameter	Alarm		DAP4 MDI Value (decimal #)	Description
	Rx Low	Rx High		
4 – Rx Status			0	Receive levels within range
		X	16	Receive levels ar out of range high
	X		32	Receive levels ar out of range low

Default thresholds have been selected to report segmental alarms are minor alarms. There are no major alarms defined for this card.

Controls

There are no firmware/software controls for this line card.

Part Numbers

The DV270SDIR Receiver options are specified when the modules are ordered. Table 4.9 provides a description of the model numbers.

Table 4.9 DV270SDIR Receiver Part Numbers

Part Number	Description
DV270SDIR	SD-SDI/DVB-ASI Receiver module, FC optical connectors (less SFP optics)
DV270SDIRSC	SD-SDI/DVB-ASI Receiver module, SC optical connectors (less SFP optics)
See Appendix A	Refer to Appendix A, for a complete list of qualified SFPs available at this time: Table A.2, <i>DV270SDI Qualified Standard SFP Specifications</i> —page A-2, Table A.3, <i>DV270SDI Qualified CWDM SFP Specifications</i> —page A-2 Table A.4, <i>DV270SDI Qualified DWDM SFP Specifications</i> —page A-3

DV270SDI Modules Installation and Checkout

This chapter describes installation and setup of the DV270SDI modules.

Introduction—page 5-1

Installation and Checkout Procedures—page 5-2

Unpacking Equipment and Inspecting for Damage—page 5-3

Installing DV270SDI Modules in a DV Shelf—page 5-4

Optical and Electrical Connections—page 5-9

Connecting Alarm Relay Contacts—page 5-14

Verifying DV270SDI Module LED Indicators—page 5-16

DV270SDI Module Configuration—page 5-21

Introduction

This section presents the procedures for installation and initial turn-on and checkout of the DV270SDIT Transmitter and DV270SDIR Receiver modules.



CAUTION *Laser Radiation—To avoid exposure to invisible laser radiation, do not look into the ends of any optical fiber connectors or bulkhead adapters. Use an optical power meter to identify active fibers. Do not assume that laser power is turned off or that a fiber is disconnected at its far end.*



WARNING *To prevent electrical shock, never install electrical equipment in a wet location or during a lightning storm.*



CAUTION DV270SDI modules are electrostatic discharge (ESD) sensitive. To prevent electrostatic discharge damage, wear a grounded wrist strap when you touch this equipment. Always place units on an approved, grounded, antistatic surface. Use antistatic packaging when transporting equipment.

CAUTION This equipment generates, uses, and can radiate radio frequency energy. If it is not installed and used in accordance with the instruction manual, it may cause interference to radio communications. It has been tested and found to comply with limits for a Class A digital device pursuant to Subpart B of Part 15 of FCC Rules, which are designed to provide reasonable protection against such interference from equipment operated in a commercial environment. Operation of this equipment in a residential area may cause interference to TV and radio reception, in which case the user, at his own expense, must take whatever measures may be required to correct the interference.

Installation and Checkout Procedures

5

The following installation and checkout procedures are placed in a logical order for a new site installation, however, they can be used independently for specific requirements.

Unpacking Equipment and Inspecting for Damage

This procedure is used to inspect and open the shipping boxes, to verify that all parts have been received, and to verify that no shipping damage has occurred.

Obtain the following tools and equipment to unpack the equipment:

- ESD Wrist band
- Anti-static mat
- Box cutter



Note Electronic equipment can be damaged by static electrical discharge. Before handling any units, Electrostatic Discharge (ESD) protection practices must always be used. To prevent ESD damage, always place the unit on an approved, electrically grounded, anti-static mat.

► To unpack modules and shelf material

1. Place the ESD wrist band on your wrist and snap the ground wire to the wrist band. Plug/attach the ground plug into a grounded ESD jack.
2. Examine the outside of the shipping carton for tears, dents, punctures, etc., that would indicate possible shipping damage. *Note any container damage.*
3. Open the shipping cartons and carefully unpack the equipment. Do not discard packing materials at this time.
4. Check each component against the packing list to verify that the correct catalog numbers and quantities were received. *Note any discrepancies.*
5. Carefully inspect each item for damage. Check for broken or bent parts, damaged connectors, bent connector pins, and other physical damage to the unit chassis.
6. Report shipping damage by filing a claim with the commercial carrier. Refer to *Contacting Artel* on page -iii if there are any problems with the equipment.
7. If the product is undamaged and all components are accounted for, discard packing material if desired. However, all components must remain in antistatic packaging until rack installation.

Installing DV270SDI Modules in a DV Shelf

Use this procedure to install a DV270SDI modules in a DV shelf. DV270SDI modules can be installed in the following DV shelves encoder/decoder slots:

- DV6000, Digital Video Transport System
- DV6408, Tributary Access System

Obtain the following tools and equipment:

- ESD Wrist band
- SFP Module (ordered separately, refer to Appendix A for a list of qualified modules)

► To install DV270SDI modules

1. If not already performed, place an ESD wrist band on your wrist and snap the ground wire to the wrist band. Plug the ground plug into a grounded ESD jack.
2. Carefully remove the module to be installed from its antistatic packaging.
3. Prior to installation, an SFP module must be installed and cabled. The transmitter and receiver modules are all shipped with the SFP fiber optic cable secured to the sheet metal side plate of the module by a pair of shipping retainer cable clamps (see Figure 5.1).

Figure 5.1

Fiber Optic Shipping Configuration

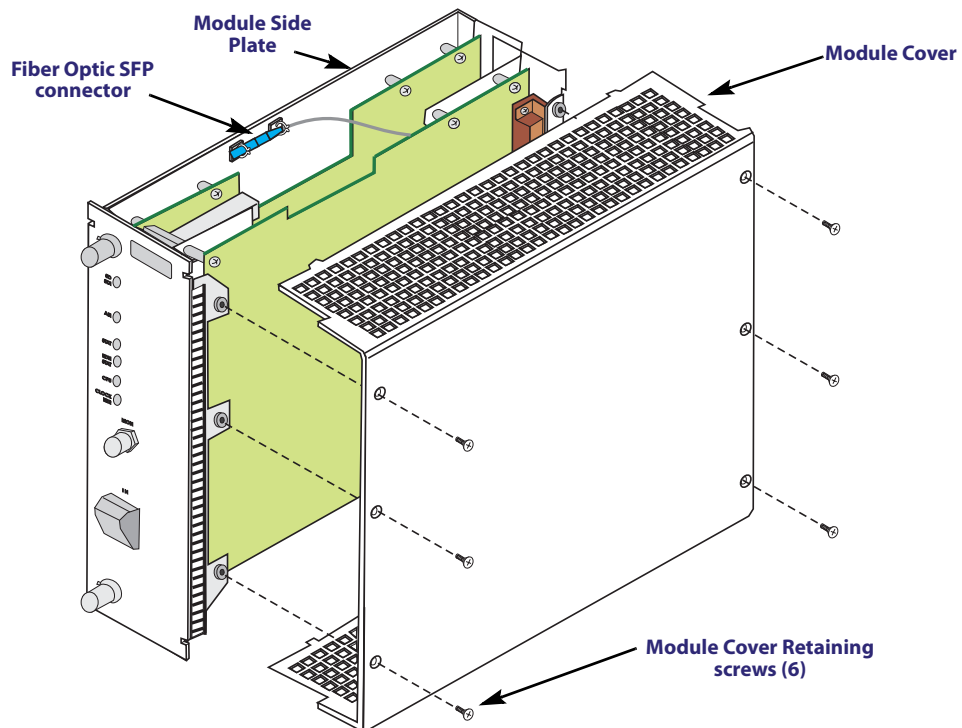

4. First remove the six (6) Phillips-head screws holding the sheetmetal cover on the right side of the module



CAUTION DO NOT separate the two cards comprising the DV270SDI module (CPU and Encoder/Decoder cards). Separating the two cards by other than Artel trained personnel can result in damage to the module, thereby voiding the product warranty.

5. Install the appropriate SFP module into the module SFP cage:

Figure 5.2

SFP Module



- a. Open the locking bail on the SFP (refer to Figure 5.2).
- b. Hold the SFP module so that the top of the SFP module is facing you (the label is showing) (refer to Figure 5.3).

Figure 5.3

SFP Insertion

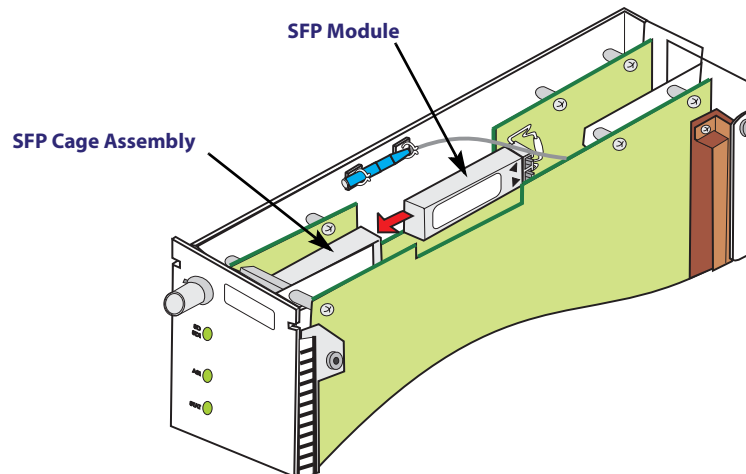

- c. Insert the SFP into the SFP cage from the component side of the PCB.

- d. Slide the module into the cage opening until it clicks into place.



Note If inserted upside down it will not fully engage. Do not force. Remove the module and reinstall as shown in the photograph.

- e. To secure the SFP module in place, close the bail lock until it clicks into the locked position.

Figure 5.4

SFP Module Inserted into SFP Cage

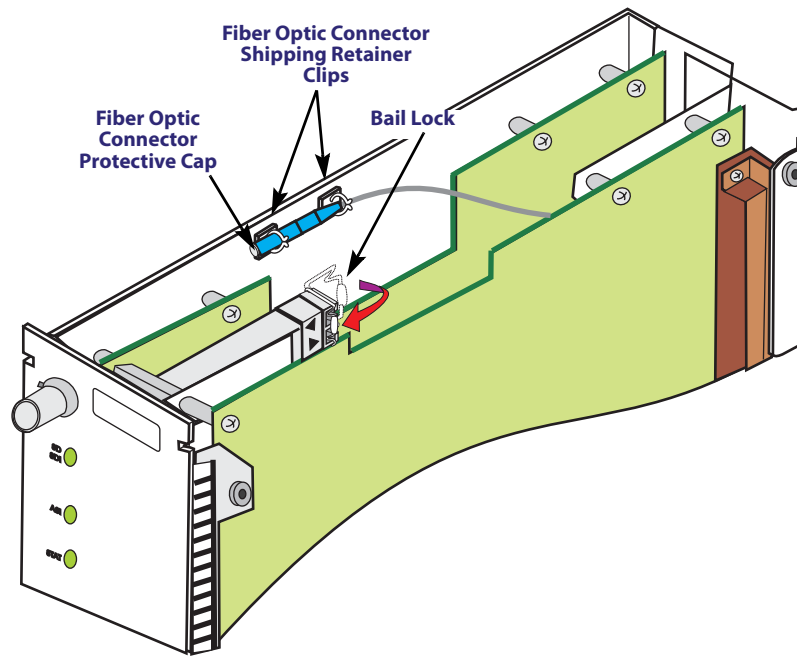

6. Refer to Figure 5.5 to connect the fiber optic cable(s) to the SFP module. The table below indicates the appropriate SFP receptacle position based on the DV270SDI module type.

DV270SDI Module	SFP Receptacle
DV270SDIT Transmitter	Bottom-most
DV270SDIR Receiver	Top-most

Figure 5.5

**Fiber Optic Shipping Configuration
(Transmitter shown)**

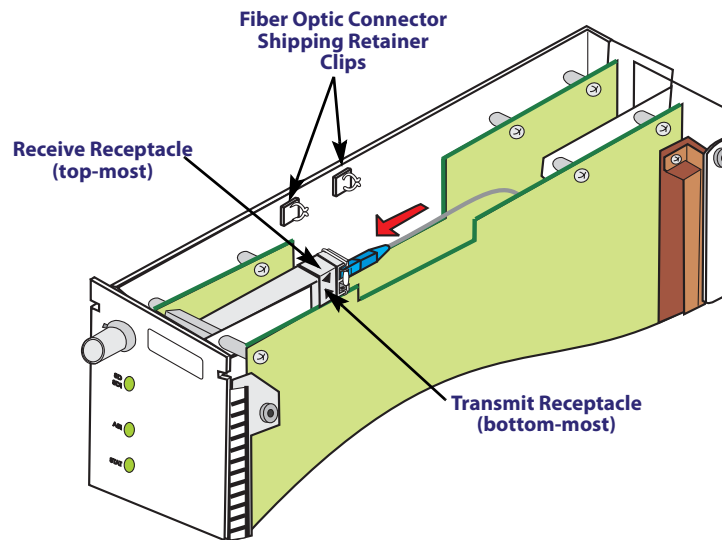

- a. Remove the fiber optic cable from the Shipping retainer clamps on the sheetmetal panel.
 - b. Remove the protective from the fiber optic connector.
 - c. Insert the fiber optic connector into the appropriate SFP Module receptacle.
7. Replace the sheetmetal cover using the six screws removed in Step 4.
 8. To install the module into the shelf, observe the position of the captive screw latch directly behind the DV270SDI face plate, by looking at the top or bottom edge of the module while turning the captive screw. The latch should be in the unlocked position as shown in Figure 5.6
 9. Turn the captive screw so the internal latch is facing to the side, so that it will not impede insertion of the module:
 - Top to the left
 - Bottom to the right
- a. For units with external tabs, observe the position of the tab from the front of the module.
 - b. For units without tabs, observe the position of the latch directly behind the face plate, by looking at the top or bottom edge of the module while turning the captive screw

Figure 5.6

Installing Modules in Shelf

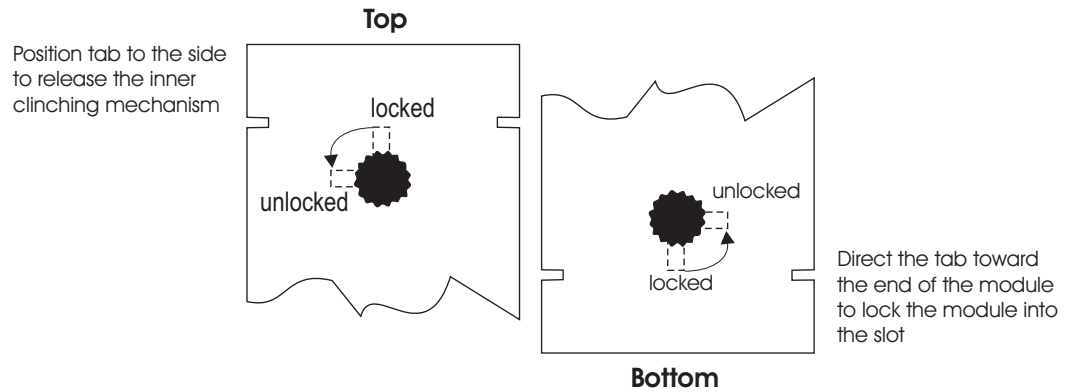

5

10. The DV270SDI can be installed in any empty encoder/decoder slot with two adjacent empty slots. Refer to Figure 5.7 for location of encoder/decoder slots (shown shaded) in the various shelves.

Figure 5.7

DV270SDI Slot Locations

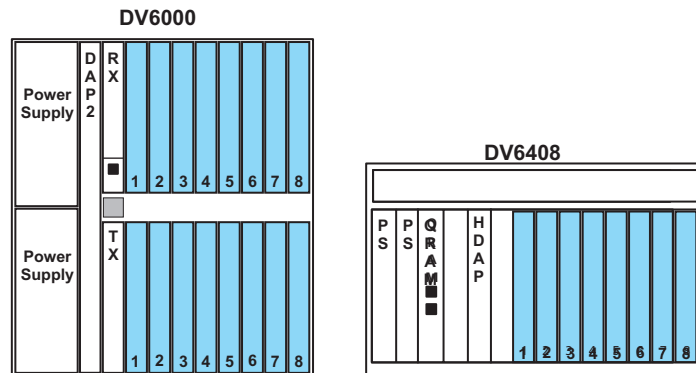

11. Slide the module into its equipment slot until the rear board edge connectors contact the motherboard connectors in the shelf backplane.
 - a. Firmly press the module fully into its slot in the equipment shelf until its connector mates with the connector in the shelf slot.
 - b. Tighten the captive screw until snug. The latch will turn simultaneously with the captive screw until it is in position, and then tighten down. Do not over tighten.
12. If additional DV270SDI modules are to be installed, repeat the above steps, starting with Step 2.

Optical and Electrical Connections

Use this procedure to interconnect the DV270SDI modules to the network.



CAUTION Electronic equipment can be damaged by static electrical discharge. When handling the Model Number assembly, always follow Electrostatic Discharge (ESD) protection practices. Wear a grounded wrist strap when you touch a unit.

Obtain the following tools and equipment:

- ESD Wrist band

Use appropriate procedure to connect DV270SDI modules:

- DV270SDIT Transmitter, use procedure *To connect DV270SDI modules optical signals* below
- DV270SDIR Receiver, use procedure *To connect DV270SDI electrical signals* on page 5-11

► *To connect DV270SDI modules optical signals*

1. If not already performed, place an ESD wrist band on your wrist and snap the ground wire to the wrist band. Plug the ground plug into a grounded ESD jack.
2. If not already performed, clean all fiber optic connectors prior to installation. Refer to appropriate DV Equipment Shelf Manual for procedure details.
3. Mark fiber cables with its destination.



CAUTION Laser Radiation—To avoid exposure to invisible laser radiation, do not look into the ends of any optical fiber connectors or bulkhead adapters. Use an optical power meter to identify active fibers. Do not assume that laser power is turned off or that a fiber is disconnected at its far end.

CAUTION — Laser Radiation. Install a protective plug on any fiber optic connector or cable that will not be used in the network. Do not rely on the connector protective cover.

4. Based on network configuration, make necessary fiber optic connections.
 - For DV270SDIT Transmitter go to Step 5.
 - For DV270SDIR Receiver go to Step 6.
5. For DV270SDIT Transmitter:



Tip Refer to Figure 3.1 on page 3-2 for receptacle locations.

- a. Lift LC optical connector (**Out**) protective cover to access the LC receptacle.
- b. Slide cable connector into the LC connector until it clicks into place.

6. For DV270SDIR Receiver:



Tip Refer to Figure 4.1 on page 4-2 for receptacle locations.

- a. Lift LC optical connector (**In**) protective cover to access the LC receptacle.
 - b. Slide cable connector into the LC connector until it clicks into place.
7. Go to connect *To connect DV270SDI electrical signals* on the next page.

► **To connect DV270SDI electrical signals**

DV270SDI serial data signals can either be connected to the front panel BNC connectors or the BNC connectors located on the rear of the shelf.



Note Connections shown below are the default (as shipped) cable configurations. For alternative connections, refer to each module's chapter.

1. If not already performed, place an ESD wrist band on your wrist and snap the ground wire to the wrist band. Plug the ground plug into a grounded ESD jack.
2. Type connection:
 - For **front panel** connections proceed to Step 3
 - For **rear panel** connections go to Step 4
3. Mark cables with source/desalination. Use Table 5.1 for front panel connections.

Table 5.1 Front Panel Connections

Module	Connector Label	Signal
DV270SDIT Transmitter	MON	Monitor In from backplane
DV270SDIR Receiver	MON	Monitor In from fiber

4. For rear shelf connections refer to appropriate connection diagram based on the DV shelf that the DV270SDI module is installed:
 - DV6000 Shelf, Figure 5.8
 - DV6408 Shelf, Figure 5.9
5. Connect SDI serial data input and or output cable(s) to the appropriate chassis receptacles as shown in the chassis/assembly diagram. Use Table 5.2 for DV rear panel connections.

Table 5.2 Front Panel Connections

Module	Connector Label	Signal
DV270SDIT Transmitter	Jn-A	SDI Out
DV270SDIR Receiver	Jn-A	SDI Out
DV6SDITR Transceiver	Jn-A	SDI In
	Jn-B	Composite Out

6. For rear shelf connections refer to appropriate connection diagram based on the DV shelf that the DV270SDI module is installed:
 - DV6000 Shelf, Figure 5.8
 - DV6408 Shelf, Figure 5.9
7. Connect SDI serial data input and or output cable(s) to the appropriate chassis receptacles as shown in the chassis/assembly diagram. Use Table 5.3 for DV rear panel connections.

Table 5.3 Rear Panel Connections

Module	Connector Label	Signal	Slot
DV270SDIT Transmitter	Jn-A	SDI Out	Right
	Jn-B	SDI Out	Right
DV270SDIR Receiver	Jn-A	Monitor In	Right
	Jn-B	Composite Out	Left

8. If additional DV270SDI modules require cabling, return to *To connect DV270SDI modules optical signals* on page 5-9.
9. When all modules have been cabled, proceed to *Verifying DV270SDI Module LED Indicators* on page 5-16.

Figure 5.8

DV6000 Shelf

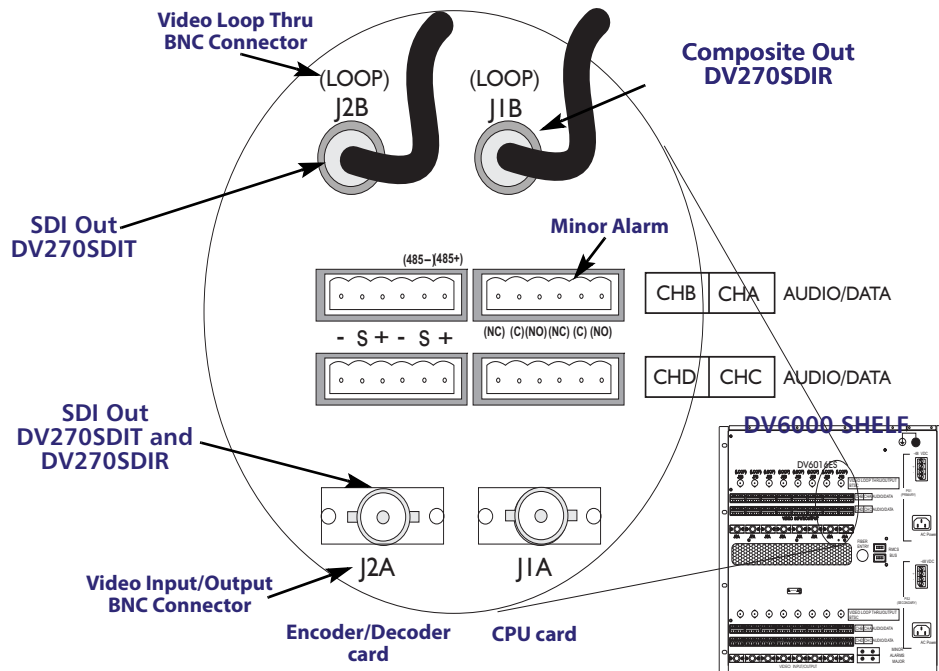
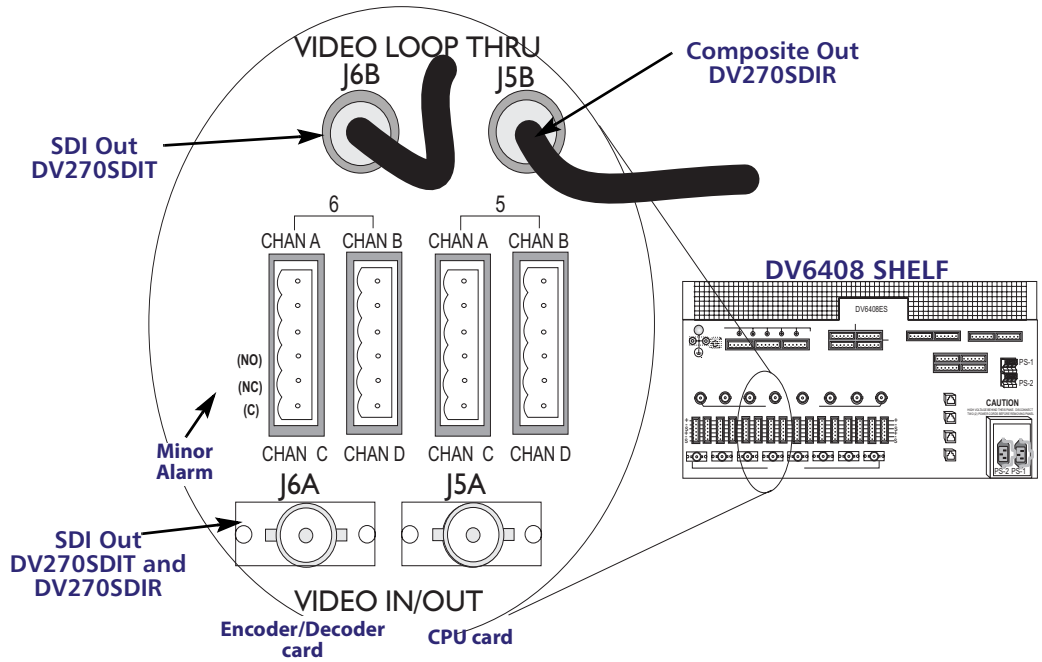

Figure 5.9

DV6408 Shelf



Connecting Alarm Relay Contacts

Each DV equipment shelf is equipped with two sets of alarm relay contacts rated per Telcordia SR-TSY-000221, one for audible alarming, and one for visual alarming. This procedure guides the use of those contacts in a local alarm system for the DV270SDI modules.

Obtain the following tools and equipment:

- ESD Wrist band
- Slotted screwdriver, blade no larger than 0.138-inch (Xcelite® R-182, or equivalent)
- Wire, 24–14 AWG, stranded or solid, shielded, twisted, pair (Belden 7837A or Belden 8441, or equivalent)
- Wire strippers

► To connect Encoder/Decoder minor alarm relays



CAUTION *Electronic equipment can be damaged by static electrical discharge. When handling DV6000 equipment, always follow Electrostatic Discharge (ESD) protection practices. Wear a grounded wrist strap when you touch a unit. Use anti-static packaging when transporting or storing units. When working on a unit, always place it on an approved, electrically grounded, anti-static mat.*

1. If not already performed, place an ESD wrist band on your wrist and snap the ground wire to the wrist band. Plug the ground plug into a grounded ESD jack.
2. Individual module alarm relay contacts for the DV270SDIT Transmitter and DV270SDIR Receiver are accessed at the **CHAN A** “AUDIO/DATA” terminals on the rear panel of the shelf. These alarm relay contacts are rated for a load of
 - 0.5A @ 125VAC or
 - 2 A @ 30VAC.

During normal operation (non-alarm state) there is continuity between the Normally Closed (NC) terminal and Common (COM). In an alarm state, there is continuity between the Normally Open (NO) terminal and Common (COM).

3. Figure 5.10 shows the terminal arrangements provided on the rear panel of the DV6408 equipment shelf (as an example) for making connections to the alarm relay contacts. Refer to the following figures for a representation of the location of the alarm connectors:
 - Refer to Figure 5.8 for the DV6000 shelf
 - Refer to Figure 5.9 for the DV6408 shelf

Figure 5.10

DV6408 Shelf
Connections (Rear of
Shelf)

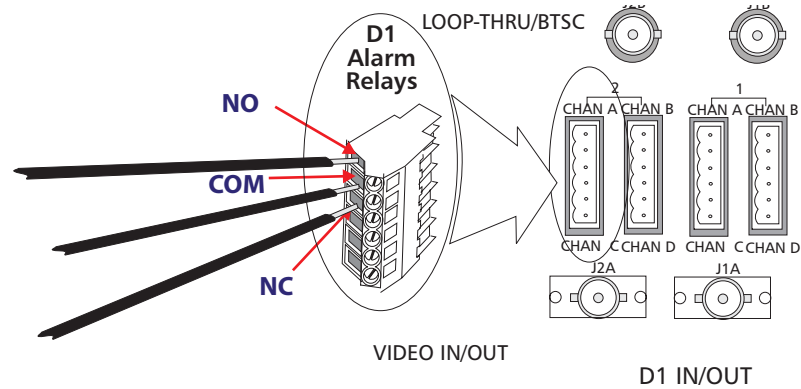

4. To connect the wires to the plug-in terminal block, use a small, slotted screwdriver to turn the screws on the plug-in terminal block to open the wire ports.
5. Insert the stripped wires from the signal source into the block according to the labeling on the terminal connectors.

5

Label	Remote Alarm
+	Normally Open (NO)
-	Normally Closed (NC)
S	Common (C)



Note For remote alarm connections, during normal operation (non-alarm state) there is continuity between the Normally Closed (NC) terminal and Common (C). In an alarm state, there is continuity between the Normally Open (NO) terminal and Common (C).







6. Tighten each wire and shield ground in the connector.
7. When complete, insert the connector plugs back into the proper receptacle.
8. For remote alarm wiring, make connections to facility alarm-system wiring according to terminal labeling.

Verifying DV270SDI Module LED Indicators

Check operation of DV270SDI using front panel LEDs or network management software.

The tables in this procedure present LED states for the DV270SDI line cards. Table 5.4 provides a legend defining the LED icons used in this section. The module LED charts attempt to indicate all common alarm combinations.

Table 5.4 LED Legend

DV270SDI Modules			
LED	Indication	LED	Indication
	Red		Red Flashing
	Green		Green Flashing
	Yellow		Unlit
			LED status is not applicable.



Note If not already performed, place an ESD wrist band on your wrist and snap the ground wire to the wrist band. Plug/attach the ground plug into a grounded ESD jack.

The following tables provide visual indications of common LED patterns:

Table 5.5, *DV270SDIT Transmitter Module Normal LED Indications*—page 5-17

Table 5.6, *DV270SDIT Transmitter Module LED Fault Indications*—page 5-18

























Table 5.7, *DV270SDIR Receiver Module Normal LED Indications*—page 5-19

Table 5.8, *DV270SDIR Receiver Module LED Fault Indications*—page 5-20

DV270SDIT Transmitter Module Normal LED Indications

For physical location of these LEDs, and a description of each, refer to Chapter 3, *DV270SDIT Transmitter Module*, Table 3.1 on page 3-3

Table 5.5 DV270SDIT Transmitter Module Normal LED Indications

SIG PRES		STAT	EDH STAT	CLOCK ERR	CPU	Indication	Notes
SD SDI	ASI						
						Normal SD-SDI operation.	No minor alarms, EDH present
						Normal DVB-ASI operation.	No minor alarms
						Normal SD-SDI operation.	No minor alarms, EDH not present
						Normal Operation: ■ OSS Communications	EMS communications

DV270SDIT Transmitter LED Fault Indications

Use Table 5.6 to identify DV270SDIT Transmitter fault indications, then follow, **“Proceed To”** directions for corrective action.

For physical location of these LEDs, and a description of each, refer to Chapter 3, *DV270SDIT Transmitter Module*, Table 3.1 on page 3-3.

Table 5.6 DV270SDIT Transmitter Module LED Fault Indications































SIG PRES ¹		STAT	EDH STAT	CLOCK ERR	CPU	Indication	Proceed To
SD SDI	ASI						
○	○	○	○	○	○	<i>Fault Condition:</i> <ul style="list-style-type: none"> Module not seated properly Module not powered 	Fault Analysis Table 6.1, <i>Item Com1 on page 6-2</i>
R	R	G	R	○	G	<i>Fault Condition:</i> <ul style="list-style-type: none"> No signal present at BNC input 	Fault Analysis Table 6.1, <i>Item Com2 on page 6-2</i>
G	G	○	○	○	G	<i>Fault Condition:</i> <ul style="list-style-type: none"> SFP not properly Installed 	Fault Analysis Table 6.2, <i>Item TX1 on page 6-3</i>
R	R	R	G	○	G	<i>Fault Condition:</i> <ul style="list-style-type: none"> No valid signal at BNC input 	Fault Analysis Table 6.2, <i>Item TX2 on page 6-3</i>
G	G	R	○	○	G	<i>Fault Condition:</i> <ul style="list-style-type: none"> Optical transmitter alarm 	Fault Analysis Table 6.2, <i>Item TX3 on page 6-3</i>
G	○	R	R	○	G	<i>Fault Condition:</i> <ul style="list-style-type: none"> EDH signal in alarm 	Fault Analysis Table 6.2, <i>Item TX4 on page 6-4</i>
G	G	R	○	○	○	<i>Fault Condition:</i> <ul style="list-style-type: none"> CPU failed 	Fault Analysis Table 6.2, <i>Item TX5 on page 6-4</i>
G	G	R	○	R	○	<i>Fault Condition:</i> <ul style="list-style-type: none"> Module is disabled, no upstream encoder 	Fault Analysis Table 6.2, <i>Item TX6 on page 6-4</i>

1. Dependent upon signal type, only one LED will be lit.

DV270SDIR Receiver Module Normal LED Indications

For physical location of these LEDs, and a description of each, refer to Chapter 4, Table 4.1, *DV270SDIR Receiver Front Panel Features*—page 4-3.

Table 5.7 DV270SDIR Receiver Module Normal LED Indications

SIG PRES		STAT	EDH STAT	CLOC KERR	CPU	Indication	Notes
SD SDI	ASI						
						Normal SD-SDI operation.	No minor alarms, EDH present
						Normal DVB-ASI operation.	No minor alarms
						Normal SD-SDI operation.	No minor alarms, EDH not present
						Normal DVB-ASI operation.	No minor alarms
						Normal Operation: ■ OSS Communications	EMS communications

DV270SDIR Receiver LED Fault Indications

Use Table 5.8 to identify DV270SDIR Receiver fault indications, then follow, **“Proceed To”** directions for corrective action. The last three columns indicate which faults apply to each of the modules.

For physical location of these LEDs, and a description of each, refer to Chapter 4, *DV270SDIR Receiver Module*, Table 4.1 on page 4-3.

Table 5.8 DV270SDIR Receiver Module LED Fault Indications

SIG PRES ¹		STAT	EDH STAT	CLOCK ERR	CPU	Indication	Proceed To
SD SDI	ASI						
○	○	○	○	○	○	<i>Fault Condition:</i> <ul style="list-style-type: none"> Module not powered Module not powered 	Fault Analysis Table 6.1, <i>Item Com1 on page 6-2</i>
○	○	○	○	○	●	<i>Fault Condition:</i> <ul style="list-style-type: none"> No signal present at BNC output 	Fault Analysis Table 6.1, <i>Item Com2 on page 6-2</i>
●	●	●	○	○	●	<i>Fault Condition:</i> <ul style="list-style-type: none"> Receive level high 	Fault Analysis Table 6.3, <i>Item RX1 on page 6-5</i>
●	●	●	○	○	●	<i>Fault Condition:</i> <ul style="list-style-type: none"> Receive level low 	Fault Analysis Table 6.3, <i>Item RX1 on page 6-5</i>
●	●	○	●	○	●	<i>Fault Condition:</i> <ul style="list-style-type: none"> No valid signal at BNC output 	Fault Analysis Table 6.3, <i>Item RX2 on page 6-5</i>
●	○	○	●	○	●	<i>Fault Condition:</i> <ul style="list-style-type: none"> EDH signal in alarm 	Fault Analysis Table 6.3, <i>Item RX3 on page 6-6</i>
●	●	○	○	○	○	<i>Fault Condition:</i> <ul style="list-style-type: none"> CPU failed 	Fault Analysis Table 6.3, <i>Item RX4 on page 6-6</i>
●	●	○	○	●	○	<i>Fault Condition:</i> <ul style="list-style-type: none"> Module disabled Violates bit rate 	Fault Analysis Table 6.3, <i>Item RX5 on page 6-6</i>

1. Dependent upon signal type, only one LED will be lit.

5

DV270SDI Module Configuration

This procedure contains a list of items that should be verified or performed when installing a new DV270SDI module. The items are based on your network requirements.

The following configuration items assume that the DV270SDI modules have been installed in the chassis and are operational. Configuration should be accomplished using either Craft or IMI 9000 EMS software.

➤ *To configure DV270SDIT Transmitters*

Item	Action
1	Turn Laser On
2	Verify output power level.

➤ *To configure DV270SDIR Receivers*

Item	Action
1	Verify input power level.

This page intentionally left blank.

DV270SDI Module Troubleshooting Guide

This chapter covers the corrective action portion of the fault analysis procedures (Chapter 5, *Verifying DV270SDI Module LED Indicators*—page 5-16) for the DV270SDI modules.

Introduction—page 6-1

Fault Analysis Tables—page 6-1

Common—page 6-2

DV270SDIT Transmitter Related Faults—page 6-3

DV270SDIR Receiver Related Faults—page 6-5

Introduction

This troubleshooting tables are intended to assist the technician in interpreting and resolving alarm conditions reported on the DV270SDI front panel LEDs. The troubleshooting tables contained herein include:

- Possible causes
- Corrective action

Fault Analysis Tables



Note Use module front panel LEDs, Configuration Tools, or IMI 9000 monitoring software to identify alarm conditions.

Common

Table 6.1 lists the fault alarms that apply to both the DV270SDIT Transmitter and DV270SDIR Receiver modules.

Table 6.1 Common DV270SDI Module Faults

Item	Possible Cause	Actions
Com1	Module not powered Possible causes: <ul style="list-style-type: none"> Module not seated properly in shelf No shelf power 	<p>Front Panel LEDs</p> <p>No Alarm</p> <p>Module: All LEDs <i>unlit</i></p> <ol style="list-style-type: none"> Reseat module into the DV shelf. <ul style="list-style-type: none"> If any LEDs illuminate, return to the procedure that brought you here. If all LEDs remain unlit, proceed to the next step. Refer to DV equipment shelf manual for troubleshooting loss of power (see <i>Related Publications</i>—page 1-5 for manual applicable shelf part numbers).
Com2	No SD-SDI or DVB-ASI signal present at BNC input Possible causes: <ul style="list-style-type: none"> No timeslot assigned to module Defective module 	<p>Front Panel LEDs</p> <p>No Alarm</p> <p>Module: STATUS LED <i>green</i> SD-SDI, ASI SIG PRES and EDH STAT LEDs <i>red</i></p> <p>Use either Craft or IMI-9000 software to verify that proper DV timeslots have been assigned to this module. Refer to Software Users Guides for procedures (see <i>Related Publications</i>—page 1-5 for manual applicable manual part numbers).</p> <ul style="list-style-type: none"> If no timeslot assigned, assign it at this time. If proper time slot is assigned, possible defective module. Call Artel Technical Support for direction.

DV270SDIT Transmitter Related Faults

Table 6.2 lists the fault alarms that apply only to the DV270SDIT Transmitter module.



CAUTION Laser Radiation—Avoid direct exposure to beam. Outbound laser radiation associated with this product is generated by a Class 1 laser product. Disconnected optical connectors might emit invisible optical radiation. Laser light, visible or invisible, can seriously injure eyes or even cause blindness.

Table 6.2 DV270SDIT Transmitter Related Faults

Item	Possible Cause	Actions
TX1	SFP not properly installed Possible causes: <ul style="list-style-type: none"> ■ SFP not installed ■ SFP not properly seated 	<p>Front Panel LEDs</p> <p>No Alarm</p> <p>Module: STATUS LED <i>unlit</i> SD-SDI or ASI SIG PRES LED <i>green</i></p> <ol style="list-style-type: none"> 1. Verify that an SFP transceiver module is installed in the module <ul style="list-style-type: none"> ■ If Yes, proceed to the next step. ■ If No, install Artel approved SFP module.: 2. Lift SFP bail lock and unseat SFP module from the DV270SDIT Transmitter. 3. Reseat SFP module into DV270SDIT Transmitter SFP port. <ul style="list-style-type: none"> ■ If STATUS LED is now <i>green</i>, return to the procedure that brought you here. ■ If STATUS LED remains <i>unlit</i>, proceed to the next step. 4. Remove and replace SFP module with a new Artel approved module. <ul style="list-style-type: none"> ■ If STATUS LED is now <i>green</i>, return to the procedure that brought you here. ■ If STATUS LED remains <i>unlit</i>, it may indicate a defective DV270SDIT Transmitter module. Call Artel Technical Support for direction.
TX2	No <i>valid</i> SD-SDI or DVB-ASI signal at BNC input Possible causes: <ul style="list-style-type: none"> ■ Incorrect timeslot assigned ■ Incorrect data format 	<p>Front Panel LEDs</p> <p>Minor Alarm</p> <p>Module: STATUS LED <i>flashing red</i> SD-SDI or ASI SIG PRES LED <i>red</i> EDH STAT Led is <i>green</i></p> <p>Use either Craft or IMI-9000 software to verify that correct DV timeslots have been assigned to this module. Refer to Software Users Guides for procedures (see <i>Related Publications</i>—page 1-5 for manual applicable manual part numbers).</p> <ul style="list-style-type: none"> ■ If no timeslot assigned, assign it at this time. ■ If proper time slot and data format is assigned, possible defective module. Call Artel Technical Support for direction.
TX3	Optical transmitter alarm Possible causes: <ul style="list-style-type: none"> ■ Defective SFP module 	<p>Front Panel LEDs</p> <p>Minor Alarm</p> <p>Module: STATUS LED <i>flashing red</i> SD-SDI or ASI SIG PRES LED <i>green</i> EDH STAT Led is <i>unlit</i></p> <ol style="list-style-type: none"> 1. Remove and replace with a known good SFP module. Did the alarm clear? <ul style="list-style-type: none"> ■ If Yes, return to the procedure that brought you here. ■ If No, proceed to the next step. 2. Possible defective transmitter module, call Artel Technical Support for direction.

Table 6.2 DV270SDIT Transmitter Related Faults (cont'd)

Item	Possible Cause	Actions
TX4	EDH signal in alarm Possible causes: <ul style="list-style-type: none"> Errors in the serial link detected 	<p>Front Panel LEDs</p> <p>Minor Alarm</p> <p>Module: STATUS LED <i>flashing red</i> SD-SDI SIG PRES LED <i>green</i> EDH STAT Led is <i>red</i></p> <ol style="list-style-type: none"> Check coaxial cable and connections at both source and destination. Replace if defective. Possible defective transmitting device or DV6SDIT module. Check upstream transmitter.
TX5	CPU failed Possible causes: <ul style="list-style-type: none"> Hardware failure 	<p>Front Panel LEDs</p> <p>Minor Alarm</p> <p>Module: STATUS LED <i>flashing red</i> SD-SDI or ASI SIG PRES LED <i>green</i> CPU Led is <i>unlit</i></p> <p>Most probably a hardware failure in the module. Call Artel Technical Support for direction.</p>
TX6	Module is disabled Possible causes: <ul style="list-style-type: none"> No upstream encoder present 	<p>Front Panel LEDs</p> <p>Minor Alarm</p> <p>Module: STATUS LED <i>flashing red</i> SD-SDI or ASI SIG PRES LED <i>green</i> CLOCKERR Led is <i>red</i></p> <ol style="list-style-type: none"> Use either Craft or IMI-9000 software to verify that upstream encoder is present. Refer to Software Users Guides for procedures (see <i>Related Publications</i>—page 1-5 for manual applicable manual part numbers). <ul style="list-style-type: none"> If Yes, proceed to the next step. If No, install encoder module and assign proper DV timeslots. Return to the procedure that brought you here. Verify that the upstream encoder DV timeslot is correctly assigned. <ul style="list-style-type: none"> If Yes, possible defective DV270SDIT Transmitter. Call Artel Technical Support for direction. If No, assign, then return to the procedure that brought you here.

DV270SDIR Receiver Related Faults

Table 6.3 lists the fault alarms that apply only to the DV270SDIR Receiver module.

Table 6.3 DV270SDIR Receiver Related Faults

Item	Possible Cause	Actions
RX1	Receive level alarm	<p>Front Panel LEDs</p> <p>Minor High Alarm Module: STATUS LED <i>Yellow</i> SD-SDI or ASI SIG PRES LED <i>green</i></p> <p>Major Low Alarm Module: STATUS LED <i>red</i> SD-SDI or ASI SIG PRES LED <i>green</i></p> <ol style="list-style-type: none"> Low or High alarm? <ul style="list-style-type: none"> If high level alarm, proceed to Step 2. If low level alarm, go to Step 5.
	Possible causes: <ul style="list-style-type: none"> Receive level high Receive level low 	
		<div style="border: 1px solid black; padding: 5px; margin-bottom: 10px;">  <p>CAUTION Laser Radiation—Avoid direct exposure to beam. Inbound laser radiation associated with this product is generated by a Class 1 laser product. Disconnected optical connectors might emit invisible optical radiation. Laser light, visible or invisible, can seriously injure eyes or even cause blindness.</p> </div> <ol style="list-style-type: none"> Remove optical fiber from the SFP receive receptacle and measure the input power level. <ol style="list-style-type: none"> If it is within limits, proceed Step 3. If it exceeds limits, go to Step 4. Suspect faulty SFP module. Remove and replace. If the optical power exceeds the SFP receiver limits, an optical attenuator is required to bring the input power level into range. Remove optical fiber from the SFP receive receptacle and measure the input power level. <ol style="list-style-type: none"> If it is within limits, suspect a faulty SFP, remove and replace. If it below limits, check for dirty or broken fiber, or upstream transmitter problem.
RX2	No valid SD-SDI or DVB-ASI signal at BNC output	<p>Front Panel LEDs</p> <p>Minor Alarm Module: STATUS LED <i>unlit</i> SD-SDI or ASI SIG PRES LED <i>red</i></p> <p>Use either Craft or IMI-9000 software to verify that proper DV timeslots have been assigned to this module. Refer to Software Users Guides for procedures (see <i>Related Publications</i>—page 1-5 for manual applicable manual part numbers).</p> <ul style="list-style-type: none"> If no timeslot assigned, assign it at this time. If proper time slot is assigned, possible defective module. Call Artel Technical Support for direction.
	Possible causes: <ul style="list-style-type: none"> Incorrect timeslot assigned Incorrect data format 	

Table 6.3 DV270SDIR Receiver Related Faults (cont'd)

Item	Possible Cause	Actions
RX3	EDH alarm - bit errors detected Possible causes: <ul style="list-style-type: none"> Upstream transmitter defective Local receiver/transceiver defective 	<p>Front Panel LEDs</p> <p>Minor Alarm Module: STATUS LED unlit SD-SDI SIG PRES LED green EDH STAT Led is red</p> <p>A CRC check-word is generated by the upstream transmitter/transceiver and verified by the local receiver/transceiver.</p> <ol style="list-style-type: none"> Check upstream transmitter/transceiver EDH STAT LED. <ul style="list-style-type: none"> If green, proceed to Step 3. If red, proceed to the next step. Troubleshoot upstream transmitter/transceiver. <ul style="list-style-type: none"> Verify that the SFP on both ends supports the data rate used (i.e. verify that the SFP supports 1.5Gbs for HD-SDI signals) Clean fiber connectors. Check for fiber damage. Measure transmitter output Possible defective receiver/transceiver module. call Artel Technical Support for direction.
RX4	CPU failed Possible causes: <ul style="list-style-type: none"> Hardware failure 	<p>Front Panel LEDs</p> <p>Minor Alarm Module: STATUS LED unlit SD-SDI or ASI SIG PRES LED green CPU Led is unlit</p> <p>Most probably a hardware failure in the module. Call Artel Technical Support for direction.</p>
RX5	Module is disabled Possible causes: <ul style="list-style-type: none"> Module disabled? Violates bit rate? 	<p>Front Panel LEDs</p> <p>Minor Alarm Module: STATUS LED unlit SD-SDI or ASI SIG PRES LED green CLOCKERR Led is red</p> <p>Use either Craft or IMI-9000 software to verify that proper DV timeslots have been assigned to this module. Refer to Software Users Guides for procedures (see <i>Related Publications</i>—page 1-5 for manual applicable manual part numbers).</p> <ul style="list-style-type: none"> If no timeslot assigned, assign it at this time. If proper time slot is assigned, possible defective module. Call Artel Technical Support for direction.

DV270SDI Module Maintenance

This manual provides information on Artel's DV6000 family of DV270SDI line cards.

Hardware Related

SFP Replacement—page 7-1

Defective Fan Assembly—page 7-6

Firmware Related

Firmware Upgrades—page 7-7

Hardware Related

SFP Replacement

This procedure should be used to remove and replace an SFP module.



CAUTION *DO NOT* separate the two DV270SDI module cards (CPU and Encoder/Decoder cards). Separating the two cards, by other than Artel trained personnel, can result in damage to the module components, and thereby voiding of the product warranty.

Obtain the following tools and material:

- ESD Wrist band
- Antistatic bag
- #1 Phillips-head screwdriver

➤ **To remove and install an SFP module**

1. If not already performed, place an ESD wrist band on your wrist and snap the ground wire to the wrist band. Plug the ground plug into a grounded ESD jack.
 - For removal proceed to Step 2
 - For installation go to Step 10

SFP Removal

2. Disconnect fiber optic cable from the front panel connector, and insert a protective cap.
3. To loosen the module from the shelf, turn the captive screw so the internal latch is facing to the side, so that it will not impede extraction of the module:
 - Top to the right
 - Bottom to the left
 - a. For units with external tabs, observe the position of the tab from the front of the module.
 - b. For units without tabs, observe the position of the latch directly behind the face plate, by looking at the top or bottom edge of the module while turning the captive screw

Figure 7.1

Installing Modules in Shelf

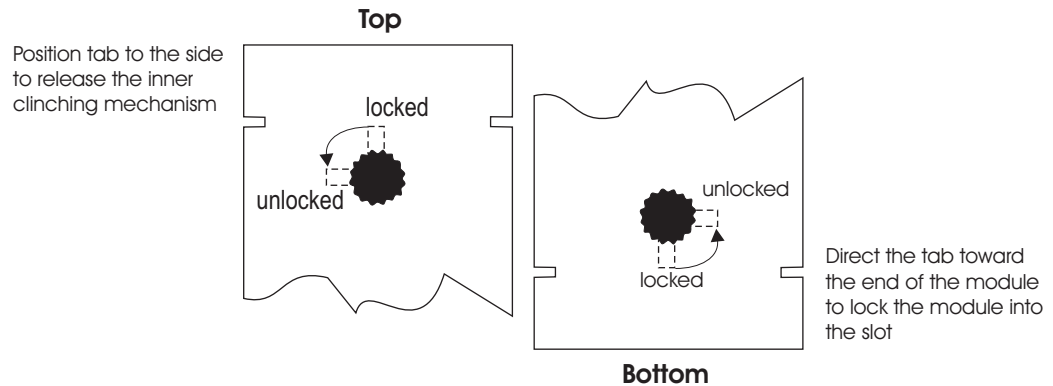

4. Once loose, remove the module from the shelf.
5. Using a #1 Phillips-head screwdriver, remove the six screws from the left side plate of the module (refer to Figure 7.2).
6. Remove the side plate so that the SFP and fiber optic cable are accessible.



CAUTION DO NOT separate the two DV270SDI cards (CPU and Encoder/Decoder). Separating the two cards by other than Artel trained personnel can result in damage to the module, thereby voiding the product warranty.

Figure 7.2

**Removing DV270SDI
Cover Plate**

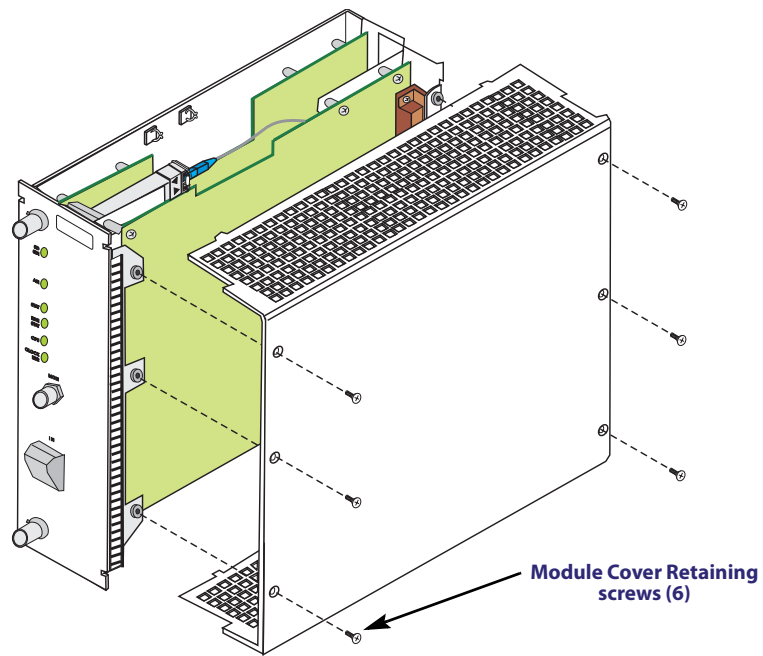

7. Using your thumb and index finger squeeze the fiber optic connector release latch, and slide the fiber optic connector out of the SFP module (refer to Figure 7.3).

Figure 7.3

DV270SDI Side View

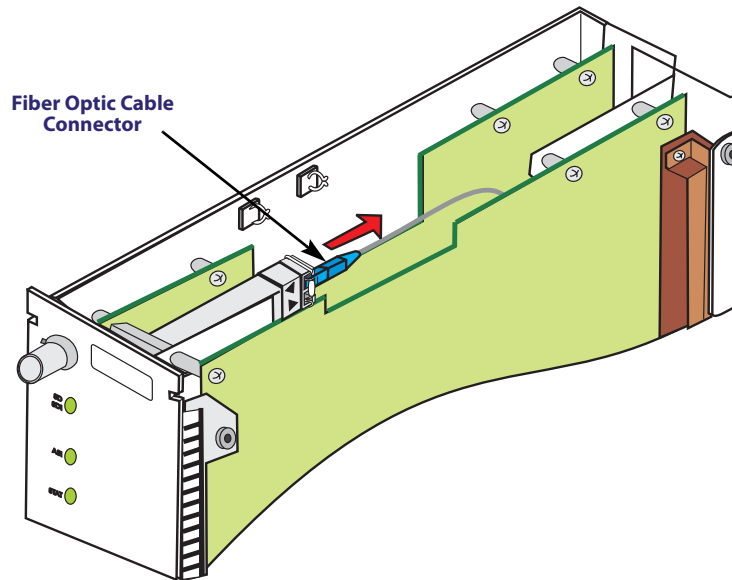

8. Referring to Figure 7.4, place a protective cap over the fiber optic cable connector then:
 - a. Place the fiber optic connector in the retaining clips (1) on the sheetmetal side plate.
 - b. Next pull the bail lock down on the SFP module (2).
 - c. Then slide the SFP module out (3) of its retaining cage.

Figure 7.4

**Removing Fiber
Optic Connector**

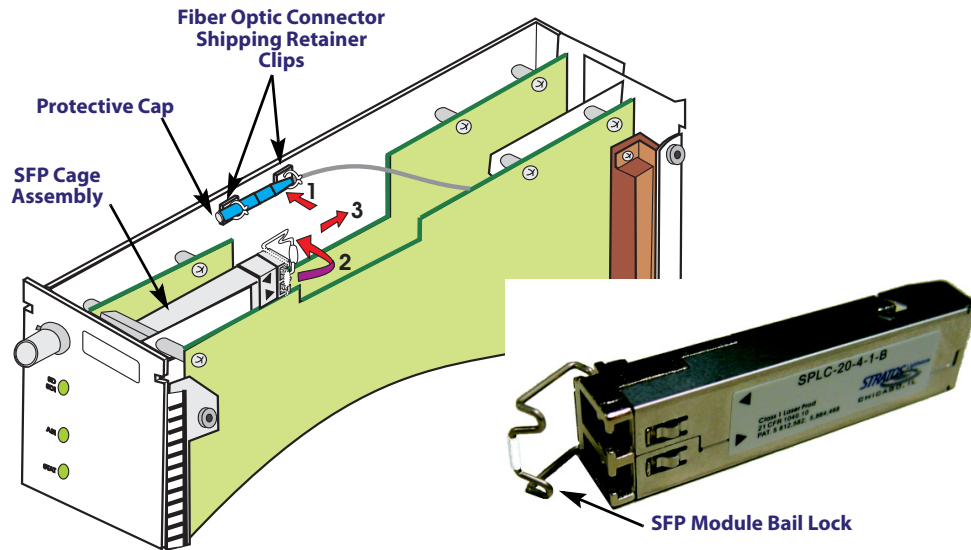

9. Place the SFP module in an anti-static bag.

SFP Installation

10. Carefully remove the new SFP module from its antistatic packaging.
11. Position the module such that the SFP receive connector is at the top of the DV270SDI module, and the rear of the SFP module is facing out (refer to Figure 7.5).
12. Install the appropriate SFP module into the module SFP cage:
 - a. Open the locking bail on the SFP (refer to Figure 7.4).
 - b. Hold the SFP module so that the top of the SFP module is facing you (the label is showing) (refer to Figure 7.5).

Figure 7.5

SFP Insertion

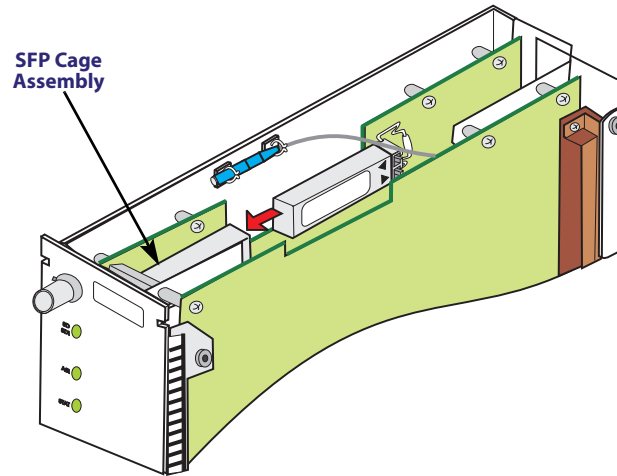

- c. Insert the SFP into the SFP cage from the component side of the PCB.
- d. Slide the module into the SFP cage opening until it clicks into place.



Note If inserted upside down it will not fully engage. Do not force. Remove the module and reinstall as shown in the photograph.

- e. To secure the SFP module in place, close the bail lock until it clicks into the locked position (refer to Figure 7.6).

Figure 7.6

SFP Module Inserted into SFP Cage

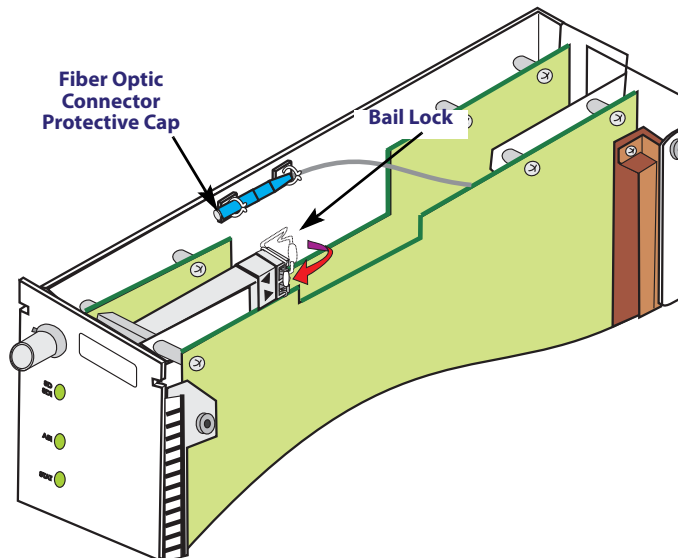

13. Refer to Figures 7.6 and 7.7 to connect the fiber optic cable(s) to the SFP module. The table below indicates the appropriate SFP receptacle position based on the DV270SDI module type.

DV270SDI Module	SFP Receptacle
DV270SDIT Transmitter	Bottom-most
DV270SDIR Receiver	Top-most

Figure 7.7

**Fiber Optic Shipping Configuration
(Transmitter shown)**

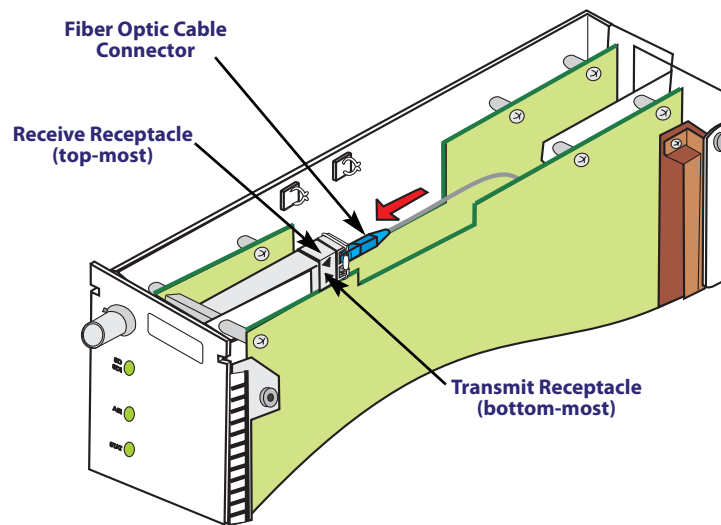

- a. Remove the fiber optic cable from the shipping retainer clamps on the sheetmetal panel.
 - b. Remove the protective cap from the fiber optic connector.
 - c. Insert the fiber optic connector into the appropriate SFP Module receptacle.
14. Replace the sheetmetal cover using the six screws removed in Step 5.
 15. Refer to *Installing DV270SDI Modules in a DV Shelf* procedures, Step 8 on page 5-7 to reinsert the module back into the shelf.

Defective Fan Assembly

The transmitter fan assembly **is not** field replaceable.



CAUTION DO NOT attempt to replace a defective fan assembly. Disassembling and reassembling the modules PCBs can result in improper alignment causing damage to PCB components, thereby voiding the product warranty. Return the module to Artel for repair.

Firmware Related

Firmware Upgrades

The DV270SDI line card has two processors.

- One processor can be uploaded/downloaded remotely via IMI 9000 software and locally using Configuration Tools, IMI 9000 monitoring software, or MDI software.
- The second processor (MSP430 processor) can only be downloaded locally via special cable and CLI software.

Call Artel Technical Support for assistance.

This page intentionally left blank.

DV270SDI Module Specifications

This Chapter provides information on Artel's DV270SDI family of line cards and qualified SFP Transceiver modules

- Table A.1, *DV270SDI Specifications*—page A-1
- Table A.2, *DV270SDI Qualified Standard SFP Specifications*—page A-2
- Table A.3, *DV270SDI Qualified CWDM SFP Specifications*—page A-2
- Table A.4, *DV270SDI Qualified DWDM SFP Specifications*—page A-3

Table A.1 DV270SDI Specifications

Characteristic	Specification	
Optical Characteristics	DV270SDIT	DV270SDIR
Transmit		
Wavelength	C-band	
Channel Spacing	DWDM 100GHz	
	CWDM 20nm	
Data Rate	270Mbps	
Reach, km	Short 40	
	Long 80	
Receive		
Wavelength, nm typical		1310 to 1550
Data Rate		270Mbps
Sensitivity, dBm, minimum	Extended and Long Reach	-28
	Short Reach	-24
	Ultra-Short Reach	-20
Power, dBm maximum (Ultra-Short Reach)		-3
Mechanical Specifications		
Size (W x H x D), inches (cm)	2.5 x 8.7 x 9.4 (6.35 x 22.10 x 23.88)	
Weight, pounds (kg)	< 5 (2.27)	< 5 (2.27)
Power Consumption, W, max. @ ambient ¹	< 12	< 10
	+5VDC +5V @ 1.6A	+5V @ 1.3A
	-5VDC -5V @ 0.2A	-5V @ 0.2A
	+12VDC +12V @ 0.1A	+12V @ 0.1A
	-12VDC -12V @ 0.1A	-12V @ 0.1A
Electrical Connectors	BNC	
Optical Connectors	SFP module (not included)	
Alarm Contact ratings	0.5A @ 125 VAC, 1A @ 30 VDC	

Table A.1 DV270SDI Specifications (cont'd)

Characteristic		Specification
Environmental Specifications		
Temperature ² :	Operating	0°C to 55°C (with fans operating)
	Storage	-20°C to 70°C
Relative Humidity (noncondensing)	Operating	10 to 90%
	Storage	0 to 95%

1. These figures represent the maximum allowable current draw on a single PSB Power Supply.
2. A chassis fan assembly is required

The following tables contain a list of SFP modules that have been qualified as to the release date of this manual. Contact Artel Technical Support for an up-to-date list.

Table A.2 DV270SDI Qualified Standard SFP Specifications

Artel Part Number	Specification						
	Rate	Wavelength (nm)	Link Distance (km)	Rx Sensitivity (dB) typ.	Rx Type	Tx Output Pwr (dB) typ.	Laser type
1501072	270Mb only	1310	20	-30	pin	-11	FP
1501073	270/1.4G	1550	50	-22	pin	-2.5	DFB

Table A.3 DV270SDI Qualified CWDM SFP Specifications

Artel Part Number	Specification						
	Rate	Wavelength (nm)	Link Distance (km)	Rx Sensitivity (dB) typ.	Rx Type	Tx Output Pwr (dB) typ.	Laser type
1501074	270/1.4G	1470	60	-22	pin	2.5	DFB
1501075	270/1.4G	1490	60	-22	pin	2.5	DFB
1501076	270/1.4G	1510	60	-22	pin	2.5	DFB
1501077	270/1.4G	1530	60	-22	pin	2.5	DFB
1501078	270/1.4G	1550	60	-22	pin	2.5	DFB
1501079	270/1.4G	1570	60	-22	pin	2.5	DFB
1501080	270/1.4G	1590	60	-22	pin	2.5	DFB
1501081	270/1.4G	1610	60	-22	pin	2.5	DFB
1501082	270/1.4G	1470	100	-30	APD	0.5	DFB
1501083	270/1.4G	1490	100	-30	APD	0.5	DFB
1501084	270/1.4G	1510	100	-30	APD	0.5	DFB
1501085	270/1.4G	1530	100	-30	APD	0.5	DFB
1501086	270/1.4G	1550	100	-30	APD	0.5	DFB
1501087	270/1.4G	1570	100	-30	APD	0.5	DFB
1501088	270/1.4G	1590	100	-30	APD	0.5	DFB
1501089	270/1.4G	1610	100	-30	APD	0.5	DFB

A

Table A.4 DV270SDI Qualified DWDM SFP Specifications

DWDM		Specification					
Artel Part Number	Rate	Wavelength (nm)	Link Distance (km)	Rx Sensitivity (dB) typ.	Rx Type	Tx Output Pwr (dB) typ.	Laser type
1501090	270/1.4G	1542.936	80	-30	APD	1	DFB
1501091	270/1.4G	1542.142	80	-30	APD	1	DFB
1501092	270/1.4G	1541.349	80	-30	APD	1	DFB
1501093	270/1.4G	1540.557	80	-30	APD	1	DFB
1501094	270/1.4G	1539.766	80	-30	APD	1	DFB
1501095	270/1.4G	1538.976	80	-30	APD	1	DFB
1501096	270/1.4G	1538.186	80	-30	APD	1	DFB
1501097	270/1.4G	1537.397	80	-30	APD	1	DFB
1501098	270/1.4G	1542.936	120	-30	APD	1	DFB
1501099	270/1.4G	1542.142	120	-30	APD	1	DFB
1501100	270/1.4G	1541.349	120	-30	APD	1	DFB
1501101	270/1.4G	1540.557	120	-30	APD	1	DFB
1501102	270/1.4G	1539.766	120	-30	APD	1	DFB
1501103	270/1.4G	1538.976	120	-30	APD	1	DFB
1501104	270/1.4G	1538.186	120	-30	APD	1	DFB
1501105	270/1.4G	1537.397	120	-30	APD	1	DFB

A

This page intentionally left blank

A

Index

A

abbreviations 1-6

C

certification, table of 1-3

Compliance

 general safety 1-2

 statement of 1-2

 table of standards 1-3

contact Artel -iii

D

document conventions 1-2

DV270SDI modules

 applications 2-2

 network management 2-4

 overview 2-1

 part numbers 2-4

DV270SDIR receiver

 block diagram 4-6

 front panel 4-2

 front panel description 4-3

 functional description 4-6

 overview 4-1

 part numbers 4-10

 rear panel description 4-4

DV270SDIT transmitter

 alarm status 3-9, 4-9

 block diagram 3-6

 channel rate mode 3-4

 CPU card configuration 3-4

 functional description 3-6

 overview 3-1

 part numbers 3-10

 physical description

 front panel 3-2

 front panel description 3-3

 rear panel description 3-4

I

installation overview 5-1

installation procedures

 alarm relay connections 5-14

 LED indications

 legend 5-16

 receiver faults 5-20

 receiver normal 5-19

 transmitter faults 5-17, 5-18

 transmitter normal 5-17

 module configuration 5-21

 module installation 5-4

 unpacking 5-3

M

maintenance

 fan assembly replacement 7-6

 hardware related

 replace SFPs 7-1

 software related

 firmware upgrade 7-7

O

overview

 manual 1-1

 module 2-1

P

publications, related 1-5

R

Revision History table i-ii

S

specifications

 module A-1

 SFP A-2

 CWDM A-2

 DWDM A-3

 standard A-2

T

tools and material, table of 1-6

troubleshooting

 common faults 6-2

 introduction 6-1

 receiver faults 6-5

 transmitter faults 6-3

W

warranty B-1

Artel Video Systems

A Division of Newfound Technology Inc.
330 Codman Hill Road
Boxborough, MA 01719
Tel: 978.263.5775
Fax: 978.263.9755
www.artel.com

